

ELECTRONIC COMBAT PRINCIPLES



ABCDEFGHIJKLMNOPQRSTUVWXYZ
[]-_!@#-%&'()*+,-./0123456789

REF-111



15 SEPTEMBER 1987



DEPARTMENT OF THE AIR FORCE

15 September 1987

Flying Training

ELECTRONIC COMBAT PRINCIPLES

This pamphlet provides a basic study and reference document on electronic combat (EC). The concept of EC was developed in response to technological and organizational changes occurring in the Air Force and incorporates the functions of electronic warfare (EW), command, control, and communications countermeasures (C³CM), and suppression of enemy air defense (SEAD). The subject is introduced to the reader through a brief history followed by a broad coverage of electromagnetic radiation and its applications. Next, the C³CM systems employed in modern combat are shown so the reader may gain a knowledge of the environment in which EC must operate. From this point, the major segments of EC are presented in the order in which they are normally employed. For a current glossary of electronic terms, refer to AFM 11-1, volume 3. For abbreviations used in this pamphlet, see attachment 1.

	Page
Chapter 1—Electronic Combat (EC)	
EC Defined	5
Evolution of Electronic Warfare (EW)	6
Battle of the Beams	6
Communications Jamming	8
Radar Countermeasures.....	8
US Countermeasures Programs	8
Intelligence Support to EC	16
Summary	17
Chapter 2—Electromagnetic (EM) Radiation Principles	
EM Radiation	18
Communications Principles	22
Basic Radar Principles	25
Summary	49
Chapter 3—Command, Control, and Communications (C³) and C³ Countermeasures (C³CM)	
C ³	50
C ³ CM	50
Chapter 4—Electronic Warfare (EW)	
Electronic Support Measures (ESM)	52
Electronic Intelligence (ELINT)	54
SIGINT/ESM Operations	55
Improved Systems.....	56
Intelligence Support to EW	57
Summary of ESM.....	58
Electronic Countermeasures (ECM).....	59
Summary of ECM	78
Electronic Counter-Countermeasures (ECCM)	78
Summary of ECCM	86

Supersedes AFP 51-3, 18 June 1985.

No. of Printed Pages: 118

OPR: HQ ATC/DOT (Maj R.P. Poland)

Approved by: HQ ATC/DO (Col J.T. Ellis)

Editor: M.M. Rastellini

Distribution: F

	Page
Electro-Optics (EO)	87
Principles of IR Radiation.....	87
IR Data Chart	88
Light Amplification by Stimulated Emission of Radiation (LASAR).....	89
Active and Passive Optical Systems	91
Optical Equipment	91
Electro-Optical Countermeasures (EOCM).....	95
Modulated Light as an EO/CM	95
Infrared Countermeasures (IRCM)	95
Optical Countermeasures (OCM).....	96
Summary of Electro-Optics (EO)	97
Electronic Warfare Integrated Reprogramming (EWIR)	97
 Chapter 5—Suppression of Enemy Air Defenses (SEAD)	
SEAD	100
 Chapter 6—Air Defense Weapon Systems	
Airborne Interceptors (AI)	104
Air-to-Air Missiles (AAM)	105
Surface-to-Air Missile (SAM) Systems	108
Antiaircraft Artillery (AAA)	109
Fuses	114
Summary	115
 Figures	
1-1. Electronic Combat (EC)	5
2-1. Electromagnetic Wave Spectrum	19
2-2. Electromagnetic Wave Propagation.....	20
2-3. Frequency Measurement	20
2-4. Sine Wave Expressed in Wavelength	21
2-5. Amplitude, Frequency Modulation	23
2-6. Pulse Modulation	23
2-7. Forward Tropospheric Scattering Principle	24
2-8. Troposcatter vs Satellite Communication	24
2-9. Determining Range	25
2-10. Transmissions and Reception Cycle.....	26
2-11. Second-Time-Around Echo	27
2-12. Pulse Radar Range Resolution.....	29
2-13. Azimuth/Elevation Definition	30
2-14. Free Space Radar Equation	31
2-15. Nonstandard Propagation.....	32
2-16. Block Diagram of a Pulsed Radar System	33
2-17. Sample Radar Scopes.....	34
2-18. Circular Scan	36
2-19. Vertical Sector Scan	37
2-20. "V" Beam Scan	38
2-21. Stacked Beam Radar	38
2-22. Conical Scan	38
2-23. Helical Scan	39
2-24. Palmer-Helical Scan.....	40
2-25. Raster Scan	41
2-26. Spiral Scan	41
2-27. Palmer-Raster Scan	42
2-28. Monopulse Radar.....	42

	Page
2-29. Track-While-Scan Radar	44
2-30. Doppler Radar	46
2-31. Stationary Target	46
2-32. Target Moving Toward Radar	47
2-33. Range and Doppler vs PRF	48
2-34. Harmonic Content of a Rectangular Waveform	49
2-35. Pulse Modulated RF Waveform	49
3-1. Worldwide Military Command and Control Network	51
4-1. ESM Sensor	54
4-2. Peripheral Reconnaissance Route	55
4-3. Penetration Reconnaissance Route	56
4-4. Locating Site of Intercepted Radar	57
4-5. Identifying Type of Intercepted Radar	58
4-6. Stub/Blade Antenna	59
4-7. Horn and Phased Array Antennas	60
4-8. Vertical and Horizontal Polarization	60
4-9. Circular Polarization	61
4-10. Phase Relationships	61
4-11. Linear Array	62
4-12. Scimitar Antenna	63
4-13. Spiral Antenna and Helical Antenna	64
4-14. Burn-Through Range	65
4-15. Radar Scope Without Jamming	65
4-16. Radar Scope With Jamming	66
4-17. Spot Jamming	66
4-18. Sweep Jamming and Noise Transmitter	67
4-19. Barrage Jamming/Jamming Power vs Bandwidth	68
4-20. Barrage Transmitter	69
4-21. Modulated Jamming (Conical Scan)	69
4-22. Track-While-Scan Jamming	70
4-23. Basic Modulated Transmitter	70
4-24. Range Gate Tracking	71
4-25. Range Gate Stealer	72
4-26. Repeater ECM Transmitter	73
4-27. Stream Chaff Dispensing	73
4-28. Random Chaff Dispensing	74
4-29. Burst Chaff Dispensing	75
4-30. Decoy	75
4-31. Low Level Evasion	76
4-32. Evasive Maneuvers	76
4-33. Crosstracking, Roll-Back, and Diversionary Raids	77
4-34. Pulsed Radar With Two-Position PRF Stagger	81
4-35. Pulsed Radar With Jittered PRF	81
4-36. Sources of Radar Noise	82
4-37. Linear Receiver	83
4-38. Comparison of Receiver Responses	83
4-39. Side Lobe Jamming	84
4-40. SLC Block Antenna Patterns	85
4-41. SLC Block Diagram and Waveforms	86
4-42. The Optical Spectrum	88
4-43. Atmospheric Transmission	89
4-44. IR Data Chart	90
4-45. Basic Laser Construction	91

	Page
4-46. Schematic of Optical System	92
4-47. Reticle Pattern	93
4-48. Typical Integrated System	94
4-49. Typical Infrared Warning System	95
4-50. Intelligence Agency Interaction	98
5-1. J-SEAD Suppression Capabilities and Responsibilities	101
5-2. Radar Busting	102
5-3. Combined Airborne and Ground-Based Control System	103
6-1. AI Search Mode vs Track Mode	105
6-2. Missile Guidance System	107
6-3. SAM Using Missile and Target Tracking	110
6-4. SAM Using Track-While-Scan	111
6-5. Track-Via-Missile Concept	112
6-6. Typical AAA Battery Layout	113
6-7. Radar Proximity Fused Projectile	114
 Attachment	
1. Abbreviations	116

Chapter 1

ELECTRONIC COMBAT (EC)

"If there is a World War III, the winners will be the side that can best control and manage the electromagnetic spectrum."

Thomas H. Moorer
Admiral, US Navy
Chairman, Joint Chiefs
of Staff (1970-1974)

EC DEFINED

From World War II (WW II) through the mid-1970's, the term "electronic warfare" (EW) was used to describe military electromagnetic (EM) activity. By the late 1970's, the relentless Soviet progress in fielding highly capable military systems designed to offset United States (US) and allied military strengths caused serious reassessment of long-held concepts for dealing with the electronic battlefield. In this regard, SEAD and C³CM received strong attention by military planners. Thus it became apparent that a broad conceptual framework, adequate to the military challenges confronting us for the remainder of the century, should be established to encompass the EM actions required to support modern military operations. This framework is termed "electronic combat" (EC).

EC is action taken in support of military operations against the enemy's EM capabilities. As shown in figure 1-1, EC includes EW as well as C³CM and SEAD.

C³CM includes both defensive and offensive aspects. It is the integrated use of operational security (OPSEC), military deception, jamming, and physical destruction, supported by intelligence to deny information to, influence, degrade, or destroy adversary command, control, and communications (C³) capabilities for control of the combat forces, and to protect friendly C³ against such actions.

EW is military action involving the use of EM energy to determine, exploit, reduce, or prevent hostile use of the EM spectrum. EW can be further refined to include the three primary functional divisions of electronic support measures (ESM), electronic countermeasures (ECM), and electronic counter-countermeasures (ECCM) which will be defined later.

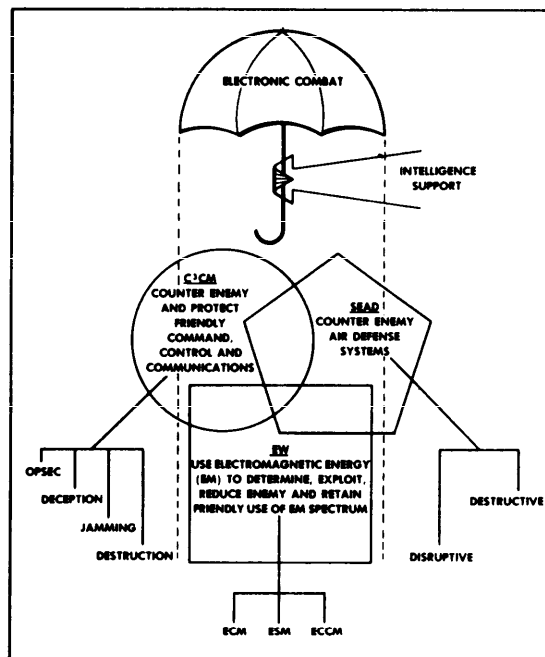

Figure 1-1. Electronic Combat (EC).

SEAD is conducted to increase the overall effectiveness of friendly air operations. SEAD is that activity which neutralizes, destroys, or temporarily degrades enemy air defense systems in a specific area to enable air operations to be successfully conducted. While ESM, ECM, and ECCM provide the electronic means to counter enemy systems, SEAD is a concept which incorporates both destructive and disruptive measures to accomplish EC objectives.

The EC definition does not limit the dimension of military action to electronic options. EC, as stated in AFM 1-9, is task oriented. Therefore, the nature of the task may require the commander to take offensive, defensive, active, or even passive measures to destroy or disrupt a targeted node or link. Commanders select the option or options which are best suited to disrupt the enemy's use of EM spectrum and which will still ensure their own operations.

Defensive EC requires the use of jam resistant communications networks and ECCM systems to maintain positive control of all echelons of the combat forces. From a defensive viewpoint, a

commander may employ hardening, dispersal, mobility, or concealment techniques in addition to any active defensive measures to prevent physical destruction. To minimize the possibility of deception, intelligence inputs from various sources must be integrated, constantly updated, and subjected to expert analysis. Offensive EC includes the physical destruction of terminal threat radars and the neutralization of enemy communication networks and intelligence gathering systems.

Active measures are actions that result in deliberate radiation or reradiation of EM energy, or require the expenditure of weapon stores. All other EM activity is considered passive.

Finally, destructive and disruptive measures describe the dimensions of operations in the EM spectrum. A destructive measure seeks the termination of the target system, its operating personnel, or both. A disruptive measure is anything that does not directly seek destruction, and its effects are reversible.

EVOLUTION OF ELECTRONIC WARFARE (EW)

EC is a multifaceted concept, designed to allow battlefield commanders total control of the EM spectrum. Although the concept of EC appears novel, its existence and employment have significantly altered the outcome of past and recent military conflicts, and the evolution of EC can be examined by tracing the chronology of EW. Prominent in this evolution is the increasing emphasis on, and appreciation for, control of the EM spectrum and its influence on the outcome of any military conflict.

Introduction

Since the beginning of WW II, military aircraft survival has been threatened by the development and improvement of radar and other EM sensors. When conjoined with the concurrent development of electronically guided air defense weapons, the threat has become increasingly dense and complex. From military necessity, the services have responded to that threat. The history of aircraft countermeasures is largely a story of repeated reactions (most of them conducted on a short-term, crash basis) in order to protect friendly aircraft. While the development and production of viable airborne countermeasures

systems have essentially followed the ebb and flow of immediate military needs, they have lagged the development of air defense weapon technology substantially. The US military services are engaged in a concerted effort to correct the deficiencies caused by this lag and to fully exploit the potential of EW for improved aircraft survivability. The lessons learned in the Vietnam War and Israeli-Arab conflicts have given ECM the proper credentials to make it a major factor in both tactical and strategic planning by all military services.

Early EW, 1916-1945

No one is quite sure when EW first began. We do know that as far back as 31 May 1916, the Admiral of the Fleet, Sir Henry Jackson, employed EW as a preliminary to the battle of Jutland. Sir Henry used evidence of coastal radio direction finders under admiralty supervision to detect movement of the German fleet. The changes in the apparent directions of arrival of radio signals from the enemy fleet were very slight, but Sir Henry dared to move the opposing British fleet on the basis of this information.

BATTLE OF THE BEAMS

The first recorded use of ECM was in the early stages of WW II when communications and radar became necessary parts of the weapons arsenal. In 1940, Churchill referred to the first employment of EW, at that time called radio countermeasures (RCM) as the "Battle of the Beams." To accomplish their bombing of Britain, the Germans established an extensive series of radio stations (200 kHz to 900 kHz) in northern France to beam signals over London. The signals were extremely directional and an aircraft equipped with a loop antenna could intercept any of these beams and follow it directly over London. This system was known as "Lorenz."

After considerable study, the British countered Lorenz with a system known as "meaconing" which was designed to actually bend the navigational beams. A meacon (masking beacon) consisted of a receiver and transmitter separated by 5 to 10 miles. The receivers intercepted the navigational beams and relayed them to the transmitters for retransmission. Hence, German bombers attempting to obtain bearings received signals from the Lorenz transmitters and the

meacons. This countermeasure was so effective that on several occasions, German crews were so completely confused and disoriented that they actually landed at British airbases.

When it became obvious to the Germans that Lorenz was effectively being countered, they switched to a new system. Two intercommunicating transmitters were established on the French coast; one transmitted dots and the other transmitted dashes. Since the two beams were transmitted parallel to one another, an aircraft flying a course directly between the beams received a solid tone and any deviation from the prescribed course resulted in the reception of either dots or dashes. The width of the solid tone was such that it enabled the German bombers to determine their position over the target within approximately 800 yards. This "Knickebein" (curtsey) system was called "Headache" by the British. The British had a choice of two countermeasures to the system: jamming or deception. If they jammed the receivers in the bombers, the Germans would most likely abandon Headache, so they used deception to neutralize the system without the Germans' knowledge. Using transmitters to strengthen one side of the beam, it was literally bent and unusable. Not so surprising, this countermeasure was called "Aspirin." The British had excellent intelligence concerning the Headache system and were able to put Aspirin into operation the very first time the Germans used Headache. For the next 2 months, the British had the Germans so confused that very few bombs were dropped on the assigned targets. Special lectures and warnings were delivered to the German Air Force assuring them that the beams were infallible and anyone who cast doubt on them would be eliminated. The German aircrews suspected that the beams were being distorted, but did not voice their suspicions.

In the fall of 1940, the Germans initiated the use of "Ruffian," a propaganda transmitter which operated 24 hours a day. Propaganda was normally transmitted from a nondirectional antenna; however, just before a raid, the transmitter switched to a directional antenna and beamed its transmission over the selected target area. In addition, the Germans used another narrow beam which crossed the propaganda beam to mark the bomb release point. The discovery of this bombing system can be credited to the people of London. They noticed that while listening to the propaganda broadcast, if their radios became increasingly louder, a raid would invariably follow. Conversely, the radios of those listening outside London would become weaker

just before a raid. Consistent reports from people in and around London soon revealed Ruffian's primary function. The countermeasure to Ruffian was known as "Bromide," and consisted of retransmitting the propaganda signal on the same frequency with a more powerful nondirectional antenna, making the navigational aid useless. The British also used directional antennas to rebroadcast the beam in such a manner that the bomb loads were dropped in the channel. The British press credited the erratic German bombdrops to evasive action against British Spitfires to keep the Germans in ignorance of the success of Bromide.

At this point in the "Wizard War" (another term used by Churchill), the Germans became quite distressed over the effectiveness of the British countermeasures programs. They equipped one squadron, "Kampf Gruppe 100," with all available navigational aids. The various aids were used alternately; and once these aircraft reached the target, they dropped incendiaries to visually mark the target for the following formations. This system was first used on November 14, 1940 to bomb Coventry. Initial British countermeasures consisted of decoy fires called "Starfish." After the KG-100 squadron had dropped its incendiaries, large numbers of Starfish were ignited in open spaces about the target area and caused wide dispersal of the bomb loads.

One of the last schemes devised by the Germans was called "Benito." At this time, frequency modulation (FM) was not commonly used, and the Germans assumed that the British would probably not be monitoring FM. (Sadly enough—they were right.) Portable FM stations were located along the bombing route in France and England, and strategically located agents actually talked the pilots in over London. To the dismay of the Germans, the British were not to be outdone. They eventually intercepted the transmission and countered very effectively by using a skilled linguist who transmitted false orders to the German pilots on the original FM frequency. This countermeasure, known as "Domino," was so effective that some of the German pilots became so disoriented they were forced to land in England. Benito was used until June 1941. The success of Domino as a countermeasure is evident from the bitter remarks heard passing between the German bombers and their controlling ground stations. The bombing of Dublin on the night of May 30-31, 1941 may have been an unforeseen and unintended result of Domino.

COMMUNICATIONS JAMMING

The first case of British jamming of radio channels occurred in the Libyan campaign during November, 1941. The British had not used communications jamming before this time because of its fear of retaliation by the Germans; however, a decision was made to jam the German tank communications operating in the 27 MHz to 33.5 MHz range. The jamming equipment, crude by today's standards, did the job effectively. However, there was one fault in the British tactics: the British neglected to provide fighter protection for the airborne jammers and the jamming was soon brought to an abrupt halt. The British also developed communications jammers to disrupt the German night-fighters' ground controlled intercept (GCI) units.

RADAR COUNTERMEASURES

When bombing raids over Germany were started, the extent of the German radar development was immediately realized. Not only were enemy interceptor aircraft equipped with airborne radar capable of locating our bombers through the heaviest overcast, or at night at distances up to 10 miles, but our aircraft were also being damaged by anti-aircraft fire directed by a very effective gun-laying radar known as the "Small Wurzburg." A similar radar, the "Giant Wurzburg," was used by the Germans for fighter control, while a 125-MHz set, the "Freya," was used for early warning. In the initial days of our bombing efforts against Germany, losses were extremely high due to the enemy's electronic weapons. The Giant Wurzburg was one of the first modern radars, since it combined a fire-control capability with its search function. Its antenna was a 25-foot diameter parabolic reflector which operated at a frequency of 570 MHz. Several approaches were used to counter these and later German radars.

"Window" (or chaff) was introduced in a raid on Hamburg on the night of July 24-25, 1943. Seven hundred and ninety-one bombers dropped (in addition to bomb loads) one bundle of 2,000 aluminum foil strips every minute—totalling over 2½ million strips weighing 20 tons. To the enemy radar defenses, this represented approximately 12,000 aircraft over Hamburg and had devastating effect on the enemy. The chaff drop reduced losses from 5.4 percent to 1.5 percent and was

spectacular justification for the British Air Force (RAF) RCM. After 2 months of use by the British, the RAF estimated that chaff had been responsible for saving at least 200 planes and between 1,200 and 1,500 men.

The first known German use of chaff was at Bizerte on September 6, 1943. Less than 50 airplanes were involved; however, the US and British warning radars reported an excess of 200 aircraft. The result was a dilution of allied fighter effort.

"Window" was also employed during the D-day landings. On D-day minus 2, the coast of Northern France presented a solid radar front—an active threat to invasion operations. Between Ostend and Cherbourg, there was a major German radar station every 10 miles. Actual count from Brest to Calais showed 6 Chimneys and 6 Hoardings for long-range early warning, 38 Freyas for medium range EW and night fighter control, 42 Giant Wurzburgs for night fighter control and coast gun control for use against low flying aircraft, 17 Coastwatchers, and Small Wurzburgs, one per flak battery.

The first task on D-day was to confuse what remained of the German early warning radar (EWR) system which still posed a formidable threat to operations of allied troop carrier and tug aircraft.

On the night preceding D-day, the confusion was accomplished by Mandrel (anti-Freya) jammers carried in eight Sterling aircraft along the south coast, and in four B-17s spaced to give cover as far as the island of Guernsey. Flying at 18,000 feet for 5 hours, these squadrons screened the approach of airborne forces to the French coast.

Meanwhile, British Bomber Command aircraft carried jammers and dropped Window and dummy parachutists inland from the Dover-Calais area. Reacting to these countermeasures, German fighter strength spent most of the night circling over the Calais area. As a result, there were no fighter attacks on the 884 transports and 105 gliders of the 9th Troop Carrier Command which landed or dropped some 15,000 troops.

US COUNTERMEASURES PROGRAMS

Work in the field of radar countermeasures in the US was started in 1942 when a small group was organized at M.I.T. under the direction of Dr. F.E. Terman. Their purpose was to develop anti-jamming devices for incorporation in our own radars.

The problem involved the development of a means to reduce the effectiveness of the enemy's radar equipment. In the early days of WW II, it became evident that radar was a very useful weapon for both ourselves and the enemy. It was also evident that it was a very vulnerable weapon. It appeared prudent to take steps to make this weapon as useless to the enemy as possible in case the enemy should attempt to use it against us, but on the other hand, it seemed essential to do something about the vulnerability of our own radars in case the enemy should attempt to jam us.

It soon became clear that the radar countermeasures program was much too extensive to be carried on as a part of radar development activities. Soon after the establishment of the radar countermeasures group, steps were taken to move it to Harvard where it was established as the Radio Research Laboratory (RRL). Under the direction of Dr. Terman, the RRL operated exclusively for Division 15 of the National Defense Research Committee (NDRC). During the 3½ years of its existence, the RRL grew to a peak strength (August 1944) of 810 people.

The first Air Force EW school began operations at Boca Raton AFB, Florida, in January 1943. The course was titled Radio Officer "C."

Two graduates of the first class, Lieutenants Ed Tietz and Bill Praun, performed the first ECM ferret operations against Japanese radar on Kiska (one of the Aleutian islands). Selected members of the first class were sent to Eglin AFB, where they activated Field 9 (now Hurlbert) and formed the 1st Proving Ground Electronics Unit (PGEU). The 1st PGEU was given responsibility for initial service testing of jammers and other EW equipment being developed. Most of this came from the RRL at Harvard or under its sponsorship.

The first B-17s equipped with ECM were modified at Oklahoma City and were then run through tests by the 1st PGEU. They were then sent to the European Theater for combat use. The problem of selling an all-out reconnaissance program to theater commanders was not difficult, for they were eager to learn the extent and location of the enemy electronic activities. Thus, more reconnaissance type B-24s were equipped, manned, and placed in the field. More and more EW observers were trained in both reconnaissance and jamming techniques. These first reconnaissance aircraft were known as ferrets for their specific task was to "uncover" any and all information possible about electronic activity in

a given area over which they operated. Radar coverage charts of many areas were drawn, showing the actual visibility of the enemy networks. These charts and other information were used to plan active countermeasure tactics for use during bombardment missions. Bombardment aircraft were being equipped with jamming transmitters (Carpet) and chaff (Window) as rapidly as production would permit.

In addition, Guardian Angel (jammer support) aircraft were developed to assist in target areas where individual aircraft were forced to penetrate the major defenses. In order to provide these Guardian Angels, the B-17 and B-24 bomb bays were equipped with a platform containing extra inverters and jamming equipment so that a minimum of 16 jamming transmitters could be operated simultaneously from a single aircraft. The technique for their use was to have a number of Guardian Angel aircraft arrive at the target just ahead of the first penetrating bombardment aircraft and to loiter in the immediate target area until the last bombing aircraft departed.

The effect of these tactics was impressive. On heavily defended targets where flak damage to aircraft had previously exceeded 60 percent, damage was reduced to less than 10 percent.

By the end of the war, nearly every bomber in the 8th Air Force (Europe) and many of the 20th Air Force (Pacific) had been equipped with at least one and, in some cases, up to four jamming transmitters. Soon after the equipment came into full use against the enemy, losses in the 8th Air Force began to drop. While initially it had been expected that an appreciable number of our bombers would fail to return from raids over Germany, the percentage of actual losses was reduced to a very low figure. Representatives of the RRL, stationed at Division 15 of the American-British Laboratory (ABL-15) at Malvern, England, and at other strategic points in the operational theaters, made operational analyses to determine the effect on the enemy.

These operational analyses were not conclusive. The Germans had lost much of their anti-aircraft equipment in bombing raids, the Luftwaffe had practically stopped operating, and the weather had also changed during the period when the statistics were accumulated. It was known that losses had decreased, but it could not be proved that the countermeasures program had achieved this result or had even helped.

It was not until after V-E Day that the truth was learned from the Germans themselves. Within a week after hostilities had ceased, almost all of

the entire staff of the ABL-15 in England were sent to various points within Germany. The records of the Reichforschungsrat (The German Office of Scientific Research and Development (R&D)) were examined, and it was determined that the American-British program was a spectacular success. German scientists confessed that they were baffled by our countermeasures activity. Representatives had talked to radar officers in the German ground forces, who declared that our countermeasures had rendered German anti-aircraft radars useless.

The sum total of the investigations in Germany confirmed the view that the ECM program had been a success. The entire Nazi radar network, according to the people operating it, had been reduced to about one-fifth of its normal effectiveness. Fairly early in the war, the Germans had learned to depend almost entirely on radar for anti-aircraft gun control because it provided a much more accurate range and was reliable in all types of weather. When the 8th Air Force began using window and electronic jamming, the German anti-aircraft crews were blinded. Try as they might, they had been unable to determine the location of our flights through the dazzling glare of their radarscopes. Orders had been issued to continue firing, in spite of the interference, in order not to reveal to us the fact that our countermeasures had been successful. So poor was the record of planes shot down under these conditions, that new orders were issued stating not to fire unless good visual aim could be obtained—orders equivalent to abandoning anti-aircraft radar entirely.

In the German laboratories, scientists had been at work attempting to lessen the vulnerability of their radar equipment ever since the British had dropped the first window in the raid over Hamburg in 1943. After the German bombing raids on England in 1940, Hitler had thought the war was won and ordered the demobilization of a great part of the German scientific effort and ordered the induction of scientists into the army. With the Hamburg raids and the capture of one of our advanced airborne radar sets, the Germans had seen the error of this decision and immediately reconstituted the scientific organization. By the end of the war, the laboratories were operating at full capacity with about half the German scientific effort in the field of electronics directed against our countermeasures activity. So large a force had been engaged in this work that efforts along other lines of scientific war developments were neglected. It was the further opinion of

investigators that the countermeasures program had nullified the German anti-aircraft fire and the entire scientific program in general, through the preoccupation of the German scientific organization with the countermeasures program.

Post WW II Activities, 1946-1950

At the close of WW II, ECM for the protection of bomber aircraft appeared to be firmly established throughout the US Army and Air Force. In Europe, the majority of B-17 and B-24 aircraft were fitted with "Carpet" jammers and chaff, and some carried ECM operators. In the Pacific, the B-24 and B-29 ECM support aircraft had been successfully employed against Japanese radar. Nevertheless, the period 1946-1949 is frequently referred to as the "ECM Holiday" since all of these capabilities were discarded during the postwar demobilization. The equipment was sold as surplus to military needs, the specialized aircraft were sent to salvage depots, and the entire organization of ECM logistics, maintenance, and operations personnel was abolished. ECM contracts with industry were terminated, the laboratories were substantially reduced, and within a few months only a few scattered experts remained in the field. During 1948 and 1949, the newly independent US Air Force did not possess a single aircraft capable of conducting an operational jamming mission nor the capability of defending itself with ECM. The US Navy was in a similar condition.

The rapid discard of WW II ECM hardware was largely justified on the basis that it had been built to jam German and Japanese radars. The war was over and this hardware, with the B-17 and B-24 aircraft, had no logical place in the postwar Air Force. The Department of Defense (DOD) was required to modernize its forces to accommodate jet aircraft, nuclear weapons, radar, and other technological advancements while faced with severe funding constraints in budget reductions. Aircraft countermeasures was a low-priority item during this period, completely overshadowed in the turmoil of postwar readjustment. The net result was that the services were required to completely rebuild their ECM capabilities in later years.

Reactivation of an ECM program was not long in coming, due principally to the hostile attitude of the Soviet Union and the developing position of the US and its European allies in opposition to the USSR. The initial steps were taken in 1947 when B-17s and C-47s were modified with

receiving and direction-finding (DF) equipment to accomplish electronic reconnaissance (ferret) operations along the periphery of the Soviet territory. Simultaneously, the Navy and the Air Force began development of better receivers, DF, and analysis equipment for air and shipborne reconnaissance operations. The ferret activity and other intelligence information disclosed a significant buildup in Soviet radar air defenses and highlighted the need for an improved collection capability and the probable need for ECM. In 1948, the nuclear deterrent mission of the Strategic Air Command (SAC) was initiated, and the buildup of an electronic reconnaissance squadron at McGuire AFB was started. The squadron was initially equipped in 1948 with a six-position "ferret" modified B-29 aircraft.

To accomplish the nuclear deterrent role, SAC was initially equipped with B-29 and B-50 aircraft, with the B-36 coming into the inventory in 1948 and the initial B-47 wing being formed in 1950. The first attempts at equipage consisted of the installation of WW II EW hardware in some B-29s and B-50s. Aircraft fitted in this manner were used in Korea. Plans were made for the rapid equipage of all SAC combat aircraft and for the production of additional jamming and chaff equipment, using the latest designs available to the laboratories at Wright-Patterson AFB. Contracts were initiated for jamming and chaff equipment beginning in 1949, and the first ECM hardware postwar vintage was delivered in 1950.

The Korean conflict did result in an additional increase in emphasis on ECM for the bomber forces and helped to accelerate the equipage of the strategic forces. The fighter aircraft employed in Korea did not encounter a significant radar threat, and as a result, were not equipped with ECM during the war.

The Soviet threat in 1950 consisted principally of very high frequency (VHF) radars of Russian origin, along with E-band GCI, height finding (HF), and anti-aircraft artillery (AAA) fire control radar copied from US equipment, with a few E- and I-band airborne interceptor radars of limited performance. The initial SAC ECM equipage consisted of WW II types against the VHF radars and new equipments, such as the AN/APT-16, to counter the E-band threats.

SAC was also required to build up its EW personnel from a cadre of fewer than 20 officers available in 1948. A school was started in 1949 at McGuire AFB, and the B-29 ferret aircraft of the newly formed electronic reconnaissance squadron were used as flying classrooms. This

school provided the initial personnel for the SAC bombardment wings. When it moved to Barksdale AFB in late 1949, its 12 aircraft of 6 ECM positions each were fully equipped. Shortly thereafter, the Air Training Command (ATC) at Keesler AFB took over the responsibilities of ECM training. In 2 years, SAC had relieved the ECM personnel shortage sufficiently to begin an active buildup of ECM capability within the bomber forces.

In 1950, development began on the countermeasures support forces within SAC. The 20th Bombardment Squadron, 2d Bomb Wing, at Hunter AFB, was designed as a test organization for the development of ECM tactics and for the operational testing of equipment. It was equipped with B-29 aircraft which were fitted with bomb-bay pallets for carrying a variety of jammers and chaff dispensing hardware. Operating jointly with the Air Proving Ground Command at Eglin AFB, the laboratories at Wright-Patterson AFB, and the Air Defense Command (ADC), the 2d Bomb Wing conducted extensive tests of a variety of hardware and tactics and had a major impact on SAC's ECM program through the development of operational concepts and the resulting establishment of requirements.

The B-29 ECM aircraft became the first ECM support aircraft of the SAC forces. In tests against ADC's AN/CPS-6B EW/GCI radars, it was found that swept jammers were highly effective in the ECM support role. Since the AN/CPS-6B radar was nearly equivalent to the Soviet TOKEN EW/GCI radar, the ECM support aircraft concept became firmly established within SAC.

Countermeasures for USAF Strategic Forces, 1950-1965

The early 1950's saw the introduction of the jet bomber into the SAC inventory, and development was started on a series of jamming systems for the B-47 and B-52. SAC planned to use automatic spot jammers in the B-47 against AAA and air interceptors (AI) fire control radars, and the AN/ALQ-3 and AN/ALQ-7 were developed by the Air Research and Development Command for that purpose. The Navy developed a similar piece of equipment in the AN/ALT-2. These jamming systems were never procured in quantity since it was decided to equip the B-47 with multiple barrage and swept jammers similar to those developed for the ECM support aircraft. This decision was made because the fighter threat in high altitude operations was considered more

serious than that from AAA, and as much jamming as possible was desired against the Soviet EW/GCI radar net. The B-29 ECM support forces were replaced with EB-47 aircraft, some of which contained multiple unattended jammers while others were configured with a manned ECM capsule equipped with three operator positions for jamming control. The "standard" B-47 bomber was equipped with six sweep/barrage jammers under control of the copilot. When the B-52 began appearing in the SAC forces, it also was equipped with six jammers. Later modifications raised this number to 9, then to 14 or 15. Over a period of years, improvements were made to the jammers and associated equipment, but the basic concept of employing manually controlled swept jammers against the Soviet defenses, concentrating principally on the EW/GCI radar systems in a high altitude penetration, remained constant until the end of the 1950's.

By 1958, development of improved ECM systems and components had been underway for several years. The improvements were based principally on the traveling wave tube (TWT) and voltage-tuned oscillators, such as the backward wave oscillator or carcinotron. The B-58 was to be equipped with a TWT system of the "track breaking" or deception repeater type and the US Navy had similar equipment in development and under small quantity procurement. The AN/ALQ-27 system based on the TWT was in development for the B-52 as part of an Air Force attempt to make a "giant leap" forward and equip the firstline SAC aircraft with a state-of-the-art jamming system.

Also in 1958, the DOD and the Weapon Systems Evaluation Group undertook a large-scale test program designed to evaluate the effectiveness of the NORAD radar defenses in an ECM environment. SAC was chosen to represent the offensive bomber force. This program, known as WEXVAL I, was seized upon as a major opportunity to exploit new ECM and ECCM technology. ECCM "fixes" were procured and installed in the air defense radars in the test area. In a similar manner, small numbers of "carcinotron" barrage jammers were built to replace the magnetron sweep jammers in the SAC aircraft. When the tests were conducted, it was demonstrated that the ECCM fixes substantially degraded sweep jamming techniques, and more modern equipment of the carcinotron or TWT variety were required to maintain the effectiveness of the SAC ECM. As a result, additional impetus was given to modernizing the AN/ALQ-27 and

to more effective jamming techniques and tactics.

The most significant development affecting SAC penetration tactics and its ECM program occurred in the summer of 1959, when intelligence disclosed that the USSR was rapidly deploying the SA-2 surface-to-air missile (SAM) system throughout its defenses. Current noise and deception jammers were not expected to be very effective against the SAMs, so it became necessary to consider low level penetration and flying under radar coverage as the prime penetration tactic. The impact of this major change in penetration concept affected plans and operations throughout the command. The tanker force was substantially expanded to provide the range increase required, the nuclear weapons had to be equipped with retardation devices for low level delivery, and ECM concepts and tactics were drastically modified. The Quail decoy was converted for low level target penetration, jamming equipments and tactics underwent a substantial change, and the concept of high altitude ECM support aircraft, as represented by the EB-47 forces, was opened to serious question.

The low level penetration decision in 1959 had an adverse effect upon the development to ECM in the US Air Force. There was no disputing the fact that ECM capability was of questionable value against radar and SAM defenses which were ineffective at low altitudes. Although SAC remained a strong advocate of EW, some of the impetus had disappeared. Within a short time, the decision to penetrate at low altitude contributed to the cancellation of the very expensive and large AN/ALQ-27 advanced ECM system, the demise of the high altitude B-70 program with its ECM configuration, the phaseout of the EB-47 ECM support aircraft, and the SAC ECM test organization, as well as substantial cutbacks in most ECM developments tailored to high altitude operations. It is interesting to speculate on what the situation would have been in North Vietnam if the US strategic offensive forces had maintained the emphasis of the mid-1950's on high altitude penetration and the ECM required for its accomplishment.

One significant development during this period provided some impetus to the countermeasures program of the services. In 1962, the USSR installed medium range ballistic missiles (MRBM) at 13 sites in Cuba, precipitating the "Cuban Missile Crisis" and a major confrontation with the US. With the MRBMs, the Soviets also supplied the Cubans with a substantial air defense capability, including the SA-2, along with Russian

crews. While the crisis was at its peak, both SAC and the US Navy had plans for immediate attack on the MRBM sites. Electronic reconnaissance disclosed that the Cuban SA-2s were equipped with the FAN SONG E SAM radar rather than the older FAN SONG B deployed to other Soviet satellite countries. Neither the B-52s nor Navy carrier aircraft were equipped with ECM to counter the FAN SONG E. Within a week, the Air Force approved a program to equip the B-52 with the appropriate ECM, and the Navy began the development of several countermeasures improvements, including the EA-6B ECM support aircraft.

Countermeasures for US Air Force Tactical Forces, 1950-1965

During the 1950's, while aircraft ECM for the strategic forces received a substantial buildup, Air Force tactical ECM forces were generally neglected. Tactical aircraft had not faced a significant radar threat either in WW II or in Korea, and although both intelligence and technology made rather accurate predictions of the future threat to fighter aircraft and the means by which the threat could be countered, ECM developments and programs in the tactical forces were very small. Most existing capability had been developed as an extension of the work done for the strategic air forces. For example, after the EB-47 ECM support program was underway, a similar capability was procured for the tactical forces in Europe, and B-66 aircraft were modified to accomplish both electronic reconnaissance and jamming support. The EW capabilities in the tactical forces were confined almost exclusively to reconnaissance organizations during the pre-Vietnam period. The EB-66 aircraft, since their peacetime mission was ferret operations, were assigned to a tactical reconnaissance wing stationed with US Air Forces in Europe (USAFE). Most EW personnel in the tactical forces were assigned to this organization to provide aircrew personnel for these aircraft.

A small program was initiated to provide ECM for fighter bombers in the late 1950's, with a similar requirement for ECM for fighters generated by ADC for its T-33 training aircraft. These requirements resulted in the QRC-160 ECM pod program which produced prototype pods in "E," "F," and "I" frequency bands beginning in 1960. Initial production contracts were not awarded until 1962. However, the pods were not

installed and used on most tactical aircraft until the requirements of Vietnam showed an immediate need for ECM on fighter aircraft. The QRC-160 I-band pods were, however, used extensively by ADC in training, test, and evaluation operations against US radar. The first QRC-160 pods employed ram airdrive turbines to drive generators, thus no aircraft onboard power was required. These pods also could be carried by the RF-101 photoreconnaissance aircraft, the F-105, and the F-4.

The Vietnam Conflict, 1965-1972

The most significant development in North Vietnam's air defense was the introduction of the Soviet SA-2 missile system and its associated radar. Sites for this system were constructed beginning in 1964 around Hanoi and Haiphong. Gradually they were constructed throughout the country. The system became operational in 1965, and on July 24th of that year, the US Air Force suffered its first loss to the SA-2 when an RF-4C was lost while on a reconnaissance mission.

The threat posed by the SA-2 caused an immediate and intense reaction by the DOD and the military services. Aircraft losses to the missile, while not prohibitive, were sufficiently high to be serious. In the initial months of the SA-2's operation in North Vietnam, it managed to down one aircraft for each 12 missiles fired, and losses were substantial for the 6-month period beginning in July 1965. A major effort was initiated by the DOD, Joint Chiefs of Staff (JCS), the US Air Force, and the US Navy to counter the system, with priority applied to those countermeasures which could be provided and deployed to the theater quickly.

Task groups were formed by the JCS and the services in the summer of 1965 to devise an effective response to the SA-2 and to coordinate the operational, technical, and industrial actions required to equip the forces with countermeasures hardware, test its effectiveness, and develop tactics for its employment. The JCS established the "Prong Tong" task group, which concerned itself primarily with the operational and tactical aspects of the threat and with the development and use of improved combat procedures for the forces in Southeast Asia (SEA). It did not directly concern itself with hardware equipage matters except to assist and arrange cooperation between the services. For example, the JCS group initiated the transfer of 50 AN/ALQ-51 jammers from the Navy to the Air Force for installation in the RF-

101 aircraft, and for the loan to the Navy by the Air Force of an SA-2 radar simulator from the training assets of SAC.

The task groups formed by the services rapidly became involved in countermeasures equipment problems as the result of the lack of the required hardware in the tactical air forces. An Air Force "Anti-SAM" task group, under the direction of the Air Staff Directorate of Requirements, conducted a broad survey of the countermeasures field and reviewed scores of proposals from the US Air Force commands and from industry. It initiated development action for a number of countermeasures systems, some of which resulted in procurement action and equipage for the forces of the US Air Force in SEA.

As SAMs and AAA radar-directed weapons became the prime defender of the North Vietnamese airspace and coverage of these systems increased, so did US aircraft losses. At that time, the only US Air Force aircraft in SEA with an ECM capability was the EB-66C. Initially, the EB-66 ECM effort was against terminal threat radars, SAMs, and AAA, but was then redirected against surveillance radars as ECM pods (jamming transmitters) for fighters were introduced to counterthreat radars. The EB-66s originally penetrated deep into North Vietnam with the strike and reconnaissance forces, but pressure from the enemy air defense system forced a retreat. Support ECM was then provided from standoff jamming orbits located in permissive airspace. EB-66 effectiveness diminished as the orbits were moved away from the target areas. In response to the continued North Vietnamese SAM and AAA threat, the US developed the "Wild Weasel" capability consisting of F-100 and later F-105G aircraft equipped with electronic radar detection equipment and antiradiation missiles (ARMs) to intercept, locate, and attack SAM and AAA radars and their associated weapons.

In SEA, Wild Weasel aircraft destroyed many SAM sites and often forced SAM operators to degrade their operations, thus giving strike aircraft a greater possibility of successfully striking their targets.

An Anti-SAM Combat Assistance Team (ASCAT) operated as an advisory group. The team planned ECM employment and Wild Weasel activities in SEA. Authorized and organized under TAC Operations Plan 105, members of the ASCAT were assigned to the Tactical Air Warfare Center (TAWC) at Eglin AFB, but were stationed at key bases, such as the 355th Tactical Fighter Wing at Takhili, the 8th Tactical Fighter Wing

at Ubon, and the 388th Tactical Fighter Wing at Korat.

In response to repeated attacks on South Vietnam, the US military was authorized in 1965 to retaliate in the north. Rolling Thunder became the largest tactical air operation in SEA. F-105 aircraft were used in an interdiction role with specific instructions to fly clear of restricted zones around Hanoi and Haiphong. Because logistical targets were unexpectedly defended by heavy surface-to-air fire, the first Air Force participation in Rolling Thunder resulted in the loss of three F-105s and two F-100s.

For Rolling Thunder to be successful, it was necessary to neutralize the North Vietnamese air defense system. Phuc Yen NVPAFB (North Vietnamese People's Air Force Base) near Hanoi, the largest interceptor base in the north, was an obvious choice for destruction, but the rules of engagement prohibited it being targeted (until 1967). This in turn prevented the gaining of air superiority, increasing the probability of concentrated air-to-air combat during each sortie. Beyond airstrike restrictions, the Air Force was experiencing difficulty in C³. Until 1965, C³ centers were located at airbases, but because the number of strike aircraft was increasing, a need developed for more immediate coordination between forward air controllers (FAC) and bombers. For this reason the Airborne Command and Control Center (ABCCC) was chosen for battlefield management. The aircraft used was a specially equipped C-130, operating under the name Hillsboro, which relayed enemy target information from FACs to the strike aircraft. The EC-121 ABCCC, the predecessor to the E-3 Airborne Warning and Control System (AWACS), was also used for C³. Although the "College Eye" was not as capable as is the AWACS, it nevertheless provided useful vectoring and early warning information to strike forces.

Because of the restrictions protecting Hanoi and Haiphong, the North Vietnamese were able to increase their AAA capability by 8 times and had introduced 25 SAM battalions by 1966. At the same time, North Vietnamese air attacks intensified, especially against the sluggish F-105s. In response to the continual MIG harassment, Operation Bolo was implemented. Operation Bolo used F-4 aircraft to fly the flight profiles using the call signs of F-105 aircraft. By having F-4s portray the F-105s, the US hoped the North Vietnamese would attack the flight with their MIGs which had been able to outmaneuver the F-105. The deception worked and the F-4s were

successful in shooting down several MIGs without losing an aircraft. By 1968, US air superiority was realized as the North Vietnamese Air Force retreated to bases in China. Unfortunately, North Vietnam's ground forces advanced into the south and were able to overtake parts of Saigon. Eventually the Tet Offensive was beaten back across the border, but not before the US and South Vietnam suffered heavy mortal and financial losses.

As the Presidential election of 1968 neared and support for American involvement in SEA wavered, Rolling Thunder's rules of engagement became more restrictive. By April 1968, President Johnson announced raids would no longer be made above the 19th parallel. Four days before the November election, the operation ceased.

After the demise of Rolling Thunder, the North Vietnamese reconstructed their air defense and rearmed in preparation for an attack across the border. Not only had the north increased the size of its air force, it had also strengthened its anti-aircraft defenses considerably. On 29 March 1972, North Vietnam launched a massive invasion into the south. In response, the US began mining the Haiphong and other harbors and initiated a new, partially unrestricted, strategic air offensive called "Linebacker."

Despite the north's reinforced air defense, the lifting of restrictions and the deployment of new weapon systems permitted Linebacker to be a successful military operation. The F-111, first introduced in 1968, reappeared in 1972 with an improved terrain avoidance radar. This allowed the plane to hug the ground and arrive over targets undetected. The odds of destroying the target increased with the introduction of the "smart" bomb. This weapon is guided by laser permitting it to strike difficult sites like bridges and railroads. Radar warning receivers also increased in effectiveness throughout the Southeast Asian Conflict, and by 1972 they were capable of signal prioritization and emitter identification. This enabled Weasel aircraft to identify and suppress numerous weapons which varied in type, frequency, and modulation. Although fighters and bombers carried self-protection jammers, the Weasels could enable strike forces to fly clear of enemy ground fire by opening a corridor to the target.

Militarily, Linebacker was devastating, but politically, only partially effective. The destruction of the north brought the North Vietnamese to the peace table, but they used this time to attempt rebuilding. Unlike its response to rearmament

following Rolling Thunder, the US reacted immediately with Linebacker II. Over 100 B-52s were made available for this strategic operation which called for 3 nights of massive bombardment. Three days later it was decided to continue Linebacker II indefinitely. After North Vietnam's small remaining supply of SA-2s had expired, B-52s flew to their targets, unmolested. During daylight, F-111s and F-105s dropped their payloads on the same sites. During the 11-day operation, North Vietnam's means of waging war was completely destroyed. This time North Vietnam was convinced that a solution for peace was in its best interest.

In terms of EW, significant milestones were reached during the Southeast Asian Conflict. Through the use of EW, combat losses were reduced and the ability to destroy enemy assets increased. The continual improvement of hardware, including radar warning receivers, jamming equipment, and new weapons, gave birth to new combat roles for aircraft and a new sophistication to warfare.

EW in the Middle East, 1967-1982

The most important fact learned from analysis of the SEA Conflict was that the coordinated use of ECM resources and tactics, rather than any single element, enabled the strike forces to successfully penetrate the North Vietnamese Air Defense System. All Middle East conflicts reaffirmed that lesson.

During the late 1960's, the Middle East became the focal point for advanced tactics involving EW. C³CM was employed during the Six Day War in 1967. The entire buildup for the war was shrouded in secrecy. From the beginning, it was obvious a preemptive strike provided the only means of survival for the Israeli forces.

The Israeli attack commenced at 0845 on 5 June 1967. The time of day was important in the goal to optimize C³CM. The angle of the morning sun at this time was ideal for an air attack. Israeli intelligence revealed that the Egyptian EWRs shut down at about 0830. Finally, the Israelis knew the Egyptian officers did not arrive at their posts until 0900. To further enhance the C³CM, the attack started under radio silence. Approaching at low level, the attacking fighters avoided any radars still operating. The operation was a complete success. Within 3 hours, the Egyptian forces were virtually destroyed. The proper use of C³CM was dramatically demonstrated.

The 1973 Arab-Israeli War lasted less than a month, yet it contained all the elements of a much longer war. It was an intense, bitterly contested conflict with each side well equipped with the weapons for modern warfare. The Egyptian and Syrian air defenses at that time were developed from Soviet design. The design stressed overlapping networks of SAM and AAA coverage. This formidable air defense network consisted of the SA-2, SA-3, SA-6, SA-7, the ZSU-23-4, and other AAA systems. While there were proven ECM from the Vietnam War for the SA-2 and SA-3 and infrared (IR) countermeasures, such as flares for the SA-7, the SA-6 proved to be a surprise. The SA-6's radars operated in a portion of the EM spectrum never used before by the Soviets. The Israelis tried to compensate for their lack of ECM against the SA-6 by flying lower, trying to get under its radar coverage. This tactic placed them into the heart of the ZSU-23-4 threat envelope and contributed to the loss of numerous aircraft. This forced the Israelis to adjust their electronic equipment, modify their tactics, and seek additional ECM equipment, such as ECM pods and chaff dispensers from the US.

However, before the tactics were changed and the new equipment arrived, the Israelis suffered heavy aircraft losses which taught them a valuable lesson. They learned ECM is an essential and vital part of the SEAD campaign.

In June 1982, the Israelis built upon their past war experiences and integrated EC assets to defeat Syrian air defenses in the Bekaa Valley. ESM was used to help locate missile sites and determine radar operating characteristics. Jamming was used to blind Syrian radars and interrupt voice transmissions. Antiradiation missiles were also used to attack radar sites. Israeli exploitation of the EM spectrum and their use of innovative tactics proved a sophisticated air defense can be defeated.

The Falklands, 1982

In contrast to the Israelis, the British experienced difficulty with EC during the Falklands Conflict. British ECM equipment, which had been designed to counter Warsaw Pact threats, was only partially effective against Argentina's western-built weapon systems. Due to their lack of modern radar and EW equipment, the British were unable to detect the launch of French built Exocet and Roland missiles on early warning receivers. The firing of seven Exocets

resulted in the loss of two ships. Ironically, they were destroyed by the ignition of excess missile fuel. None of the Exocet's warheads detonated. Early warning information may have prevented the complete loss of both ships.

The Argentines also found themselves facing friendly produced weapons. Once ashore on the Falklands, the British employed Rapier and Stinger SAMs. Because the Argentine aircraft operated at their maximum range without ECM pods, they became vulnerable to attack. Argentina also suffered in air-to-air combat. The British armed their Sea Harriers with AIM-9 Sidewinders, a "launch and leave" air-to-air missile (AAM). This allowed British pilots to engage multiple targets.

The Falklands conflict indicates that significant deficiencies existed in Argentine ECM and in British antiship missile defense. The lack of airborne early warning (AEW) systems severely limited British operations which resulted in the loss of vessels to Argentine attack. The difficulties experienced by the British and the success of the Israelis in the Bekaa Valley are contrasting examples which demonstrate the importance of controlling the EM spectrum and how using it effectively can contribute to successful military operations.

INTELLIGENCE SUPPORT TO EC

When operating against an integrated defense network, accurate information on the location and technical characteristics of the opposing electronic systems must be available to the penetrating force; gathering and disseminating this information is the proper function of intelligence. While the field of intelligence is not covered in the scope of this text, familiarity with the following definitions is desirable:

Communications Intelligence (COMINT). Technical and intelligence information derived from foreign communications by other than the intended recipient.

EC Intelligence. The product resulting from the collection, evaluation, analysis, integration, and interpretation of all available information concerning foreign nations or areas of operations immediately or potentially significant to EC.

Electronic Intelligence (ELINT). ELINT is the collection (observation and recording) and the

technical processing for subsequent intelligence purposes of information derived from foreign noncommunications EM radiations emanating from other than atomic detonations or radioactive sources.

Signal Intelligence (SIGINT). A generic term that includes both COMINT and ELINT.

SUMMARY

EC is becoming increasingly important to the conduct of military operations. Although this pamphlet addresses the application of EC in the aerial arena, EC pervades the whole realm of

warfare. EC devices are integrated into offensive and defensive air, sea, land, and space systems and affect the development and employment of equipment, tactics, and doctrine. All source intelligence is gathered on an enemy's capabilities, status of weapons systems and order of battle. The intelligence provides the information for developing appropriate equipment, tactics, and doctrine, including EC capabilities. Upon initiation of hostilities, intelligence is updated by ESM; ECM and ECCM are supplied to support friendly forces. The EC mission establishes, by electronic means, a military operational environment which will ensure the tactical initiative remains with the commander of friendly forces. In essence, the EC mission is EM domination.

Chapter 2

ELECTROMAGNETIC (EM) RADIATION PRINCIPLES

The mission of electronic combat (EC) involves military action to secure those portions of the EM spectrum (figure 2-1) needed to accomplish objectives. The effectiveness of military commanders to accomplish their mission depends on their understanding and use of personnel, equipment, facilities, and procedures. One step in that direction is the understanding of EM radiation as it relates to communications and radar equipment.

EM RADIATION

EM radiation is one example of the propagation of energy through space. This radiation is composed of two perpendicular sinusoidal waves: one electrostatic in nature, the other magnetic, both of which are at right angles to the direction of propagation as shown in figure 2-2. These two waves are in time phase with each other and travel at a constant speed through free space. This speed (186,000 statute miles per second, 162,000 nautical miles per second, or 3×10^8 meters per second) is usually referred to as the speed of light.

The EM waveform is most commonly illustrated as in figure 2-3. This waveform is a "sine wave" and represents the wavelength and amplitude characteristics of an EM wave. By tracing along the waveform through points A, B, C, D, and E, one complete cycle is outlined. If it takes one-thousandth ($1/1,000$) of a second for this cycle to occur, the waveform would then represent a frequency of 1,000 cycles per second (hertz).

Each point on the waveform also corresponds to a particular phase angle (measured in degrees) through which the wave is passing. Notice that the first cycle (points A through E) is completed in 360 degrees. Maximum values, positive and negative, correspond to the 90-degree and 270-degree phase points respectively.

The distance between points having a corresponding phase in two consecutive cycles of a sine wave is called the wavelength (λ). More simply, the wavelength can be determined by measuring the distance between the same two phase points on consecutive cycles (figure 2-4).

Frequency is defined as the number of complete cycles per unit of time for a periodic phenomenon. The EM waveform and thus the EM frequency spectrum are categorized by their periodic

characteristics. The entire spectrum extends from direct current (DC) with zero cycles per second (CPS) to cosmic rays above 10^{23} CPS. The term "hertz" (Hz), the international unit of frequency, is now more commonly used than CPS. Due to the fact that frequencies extend into extremely large ranges, it is convenient to use scientific notation to enumerate these frequencies.

Example: 6,000,000 hertz can be written as $6,000 \times 10$ hertz, 600×10^4 hertz, 6×10^6 hertz, etc.

There are terms used to categorize powers of ten (that is, 10^1 , 10^3 , 10^6 , etc.) that further aid the handling of frequency designations. The following terms are matched to their metric prefixes:

10^3 — kilo (k)	10^{-3} — milli (m)
10^6 — mega (M)	10^{-6} — micro ()
10^9 — giga (G)	10^{-9} — nano (n)
10^{12} — tera (T)	10^{-12} — pico (p)
	10^{-15} — femto (f)

Example: 6,000,000 hertz can now be expressed as 6,000 kilohertz, 6 megahertz, or 0.006 gigahertz.

Microwave Radar

The microwave region lies in frequency from 1,000 MHz to 30 GHz, just below the millimeter waves. It has been used in a multitude of applications, one of the most common being radar. Most radars in use today operate in the microwave region due to the level of available technology.

In comparison to millimeter waves, microwave radars can easily be countered by ECM and possess some inherent disadvantages which can cause errors of ambiguities. They can also be cumbersome and heavy, particularly for aircraft and other weapons applications.

A major advantage of microwave radars is their ability to detect targets at long ranges, with the limiting factors being power output and line of sight (LOS). As development continues in the millimeter wave regions, microwave radars will perform long-range search and acquisition, leaving millimeter wave radars for target tracking.

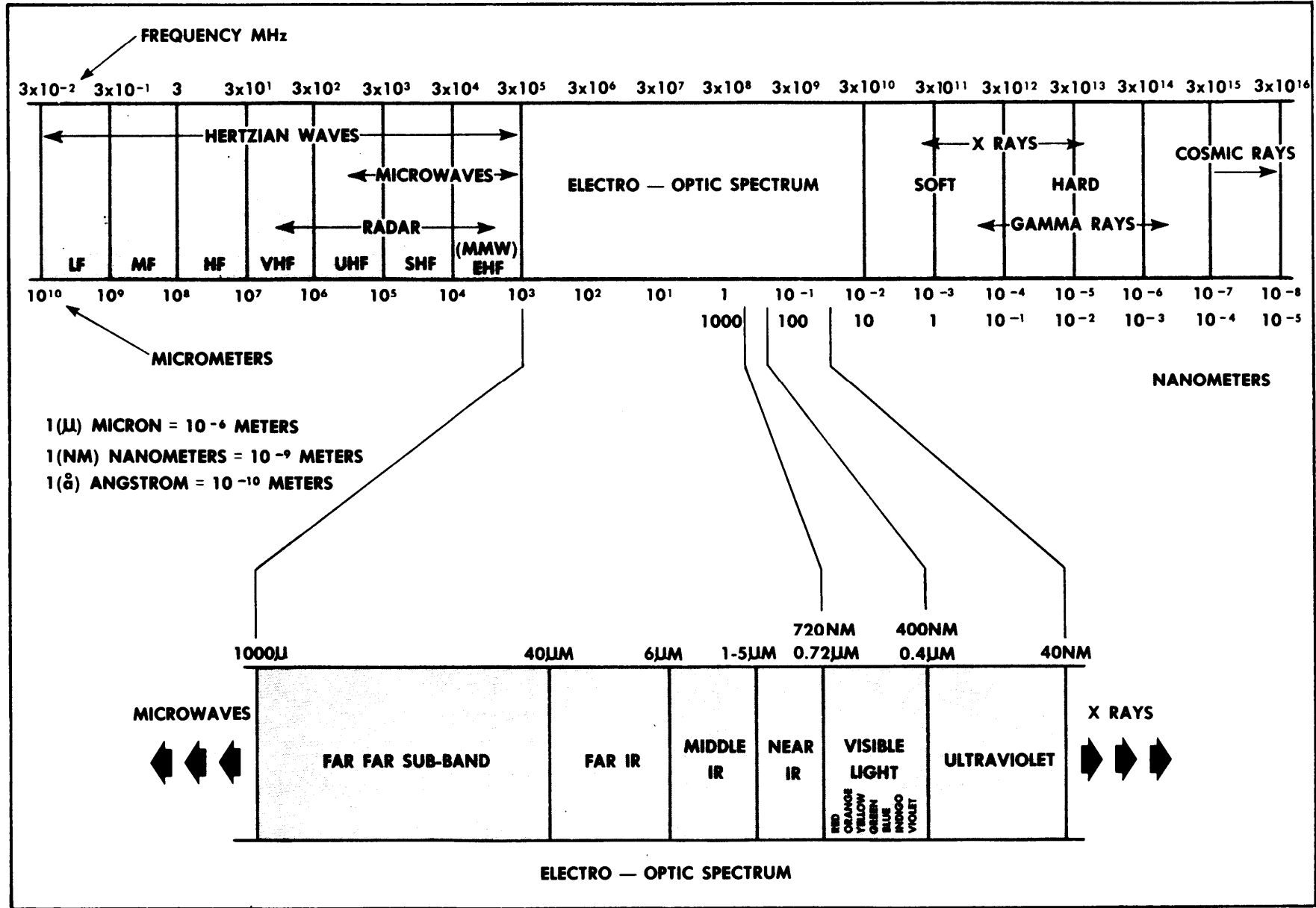

Figure 2-1. Electromagnetic Wave Spectrum.

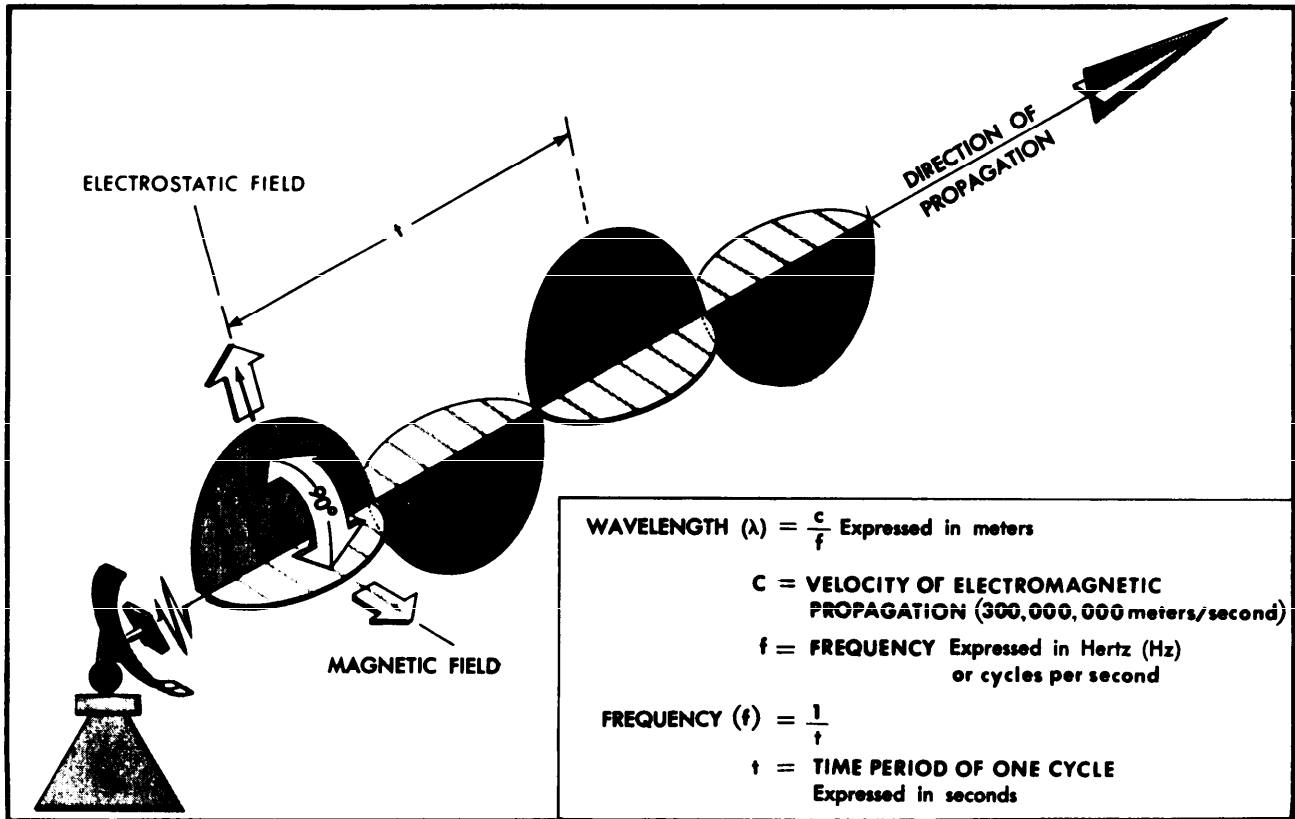

Figure 2-2. Electromagnetic Wave Propagation.

Millimeter Wave Radar

The millimeter wave portion of the EM spectrum lies between the microwave and far IR

regions with frequencies from 30 to 300 GHz. Millimeter waves have large bandwidths and allow for narrow antenna beamwidths. Due to their short wavelengths, millimeter wave components

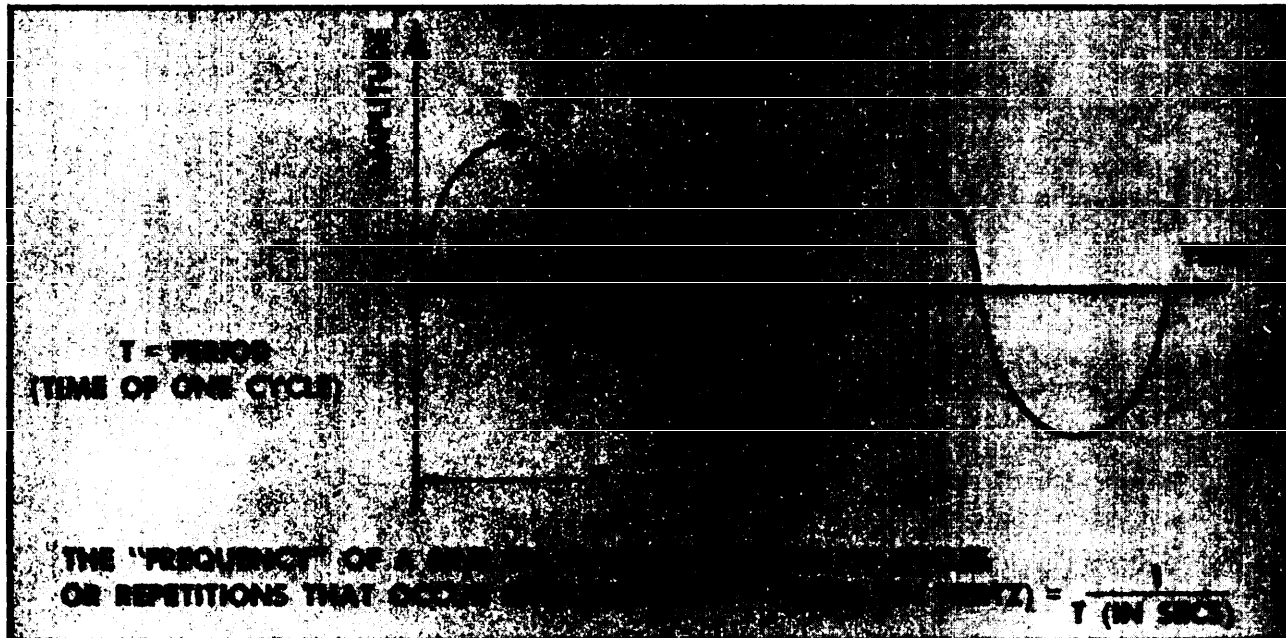

Figure 2-3. Frequency Measurement.

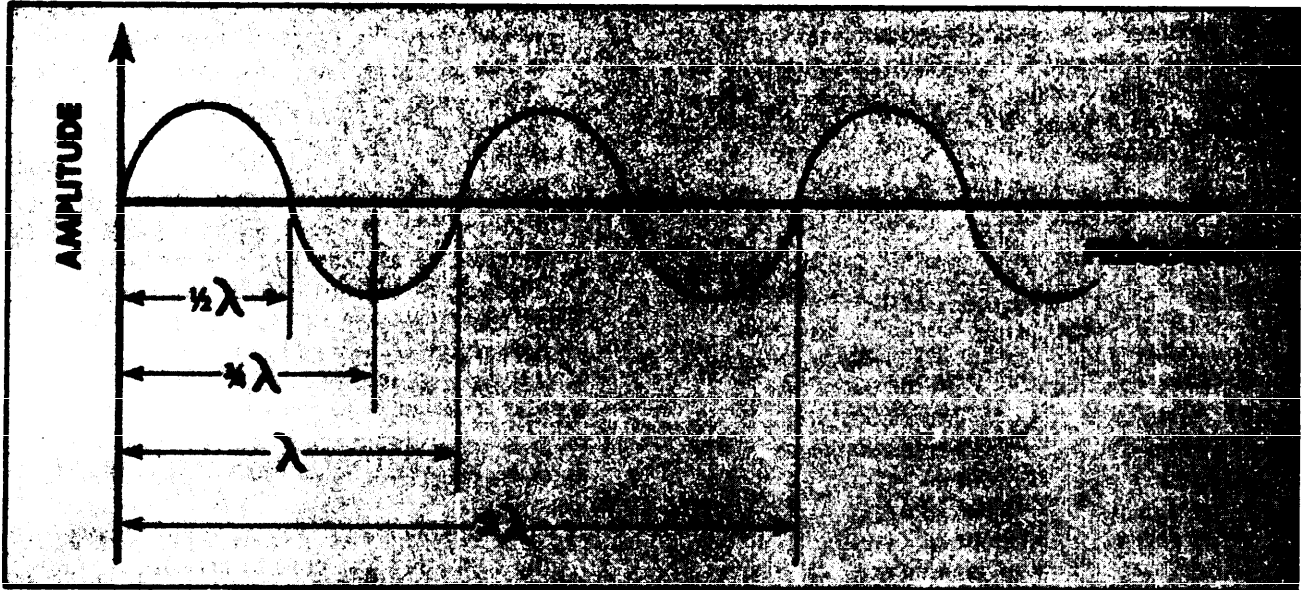

Figure 2.4. Sine Wave Expressed in Wavelength.

are smaller and lighter than most radar systems, but are highly susceptible to atmospheric absorption and attenuation, limiting range to 10 to 20 Km. Major application, therefore, involves airborne fire control radars and weapon terminal guidance systems.

Millimeter wave radars are difficult to jam because of their frequency and have increased immunity to interference. Their range resolution is better and they are more sensitive to Doppler frequency shift than most radars. The major limitation of millimeter wave radars is the lack of suitable components. As technology progresses, use of these systems will spread, especially in fire control systems.

Band Designations

There are two primary band designation systems which are now in use or have been used in the past. The first is a descriptive designation.

International Band Designators

Designation	Frequency Range
VLF very low frequency	0 to 30 kHz
LF low frequency	30 to 300 kHz
MF medium frequency	300 to 3,000 kHz
HF High frequency	3 to 30 MHz
VHF very high frequency	30 to 300 MHz
UHF ultra-high frequency	300 to 3,000 MHz
SHF super-high frequency	3 to 30 GHz
EHF extremely high frequency	30 to 300 GHz

You are probably familiar with many systems that occur within these frequency bands. The following gives examples of systems that occur within various bands:

Designation	Commercial System
VLF	60 Hz commercial power
LF	Loran C (100 kHz)
MF	Loran A (1,750 to 1,950 kHz) Commercial AM radio (535 to 1,605 kHz)
HF	Citizens band (26.965 to 27.405 MHz) WWV (2.5, 5, 10, 15, 20, and 25 MHz)
VHF	Commercial (FM) radio (88 to 108 MHz) Commercial TV (Channels 2 through 6, 54 to 88 MHz; Channels 7 through 13, 174 to 216 MHz) VOR (108 to 118 MHz)
UHF	Commercial TV (Channels 14 through 83, 470 to 890 MHz) TACAN (962 to 1,213 MHz) Air-to-ground communication (AGC) Long distance radars
SHF	Tracking radars (surface-to-air missile (SAM) systems, airborne interceptors (AIs))
EHF	Tracking radars (surface-to-air missiles (SAM))

A second system of bands and channels was established to facilitate the operational control of EW activities and is the system commonly in use in the military today. This system (shown below) is from AFR 55-44:

Frequency Band Designators

Band	Frequency MHz	Channel-Width MHz
A (Alfa)	0 to 250	25
B (Bravo)	250 to 500	25
C (Charlie)	500 to 1,000	50
D (Delta)	1,000 to 2,000	100
E (Echo)	2,000 to 3,000	100
F (Foxtrot)	3,000 to 4,000	100
G (Golf)	4,000 to 6,000	200
H (Hotel)	6,000 to 8,000	200
I (India)	8,000 to 10,000	200
J (Juliett)	10,000 to 20,000	1,000
K (Kilo)	20,000 to 40,000	2,000
L (Lima)	40,000 to 60,000	2,000
M (Mike)	60,000 to 100,000	4,000

Electromagnetic energy may be generated by an oscillator circuit and may be coupled to free space through a device known as an antenna. Perhaps the most significant fact concerning EM radiation is that it may be used to "carry" information from one location to another. This information can range from the music transmitted by a local radio station to the target position information gathered by a radar. Information is sent through space via a "carrier wave" because EM energy travels farther with less power and suffers less attenuation than does the acoustical energy which comprises the information itself. In order to transmit the information at a radio frequency (RF), the characteristics of the EM energy must be changed so that information can be impressed upon it. This is done by a process known as modulation.

There are two basic ways a "carrier" can be changed to carry information. One way, known as amplitude modulation (AM), uses the amplitude changes of the information to change the amplitude of the carrier, while the other way, known as frequency modulation (FM), uses the amplitude changes of the information to change the transmitted frequency of the carrier. These two types of modulation are illustrated in figure 2-5. The reception of music or news on an AM-FM radio and AGC are examples of AM and FM.

One type of AM, known as pulse modulation (PM), carries information gathered by radars. In

PM, the amplitude of the carrier is made to vary according to the shape of a rectangular pulse as shown in figure 2-6. This rectangular pulse acts like a switch which turns a high-powered oscillator on, leaves it on for a short period of time, and then turns it off. The result is a short, powerful burst of EM radiation used for measuring the distance from a radar set to a target. Distance (referred to as range) to a target and either the direction of the target from the radar (azimuth) or the height of the target above the ground (elevation) are the basic bits of information that a radar is designed to obtain.

COMMUNICATION PRINCIPLES

Communications play an indispensable role in the command and control network by providing decision makers with timely information needed to coordinate offensive and defensive activities. Information can come in several forms: voice communications, teletype, data link, or video transmissions. Also, information may be transferred by several methods; HF/VHF/UHF radio, microwave relay, tropospheric scatter systems, or satellite.

HF radio is a relatively low frequency device used for long range voice communication. HF radio waves have the ability to propagate along the surface of the ground, thus being able to bend over the horizon, following the curve of the earth. HF waves are also reflected by the ionosphere. When transmitted skyward, HF waves can bounce between the ionosphere and the ground several times as it propagates from the transmitter to the receiver. However, HF's usefulness is limited by several factors. First, HF has a low capacity, providing only four voice channels on each circuit. Second, HF cannot be depended on for full-time communication because it is susceptible to a high noise environment. Periods of sunspot activity or high altitude nuclear detonations make HF communication virtually impossible.

VHF and UHF radio provide LOS communication. By the process of mixing signals (multiplexing), hundreds of voice channels can be transmitted simultaneously. They can also carry teletype, data link, or video transmissions. Several methods are used to extend the LOS limited range of UHF transmissions. Microwave relay stations can increase the range and survivability of the communications system. By using directional, high-gain antennas, microwaves can be transmitted 20-40 miles by only 1 kilowatt of power.

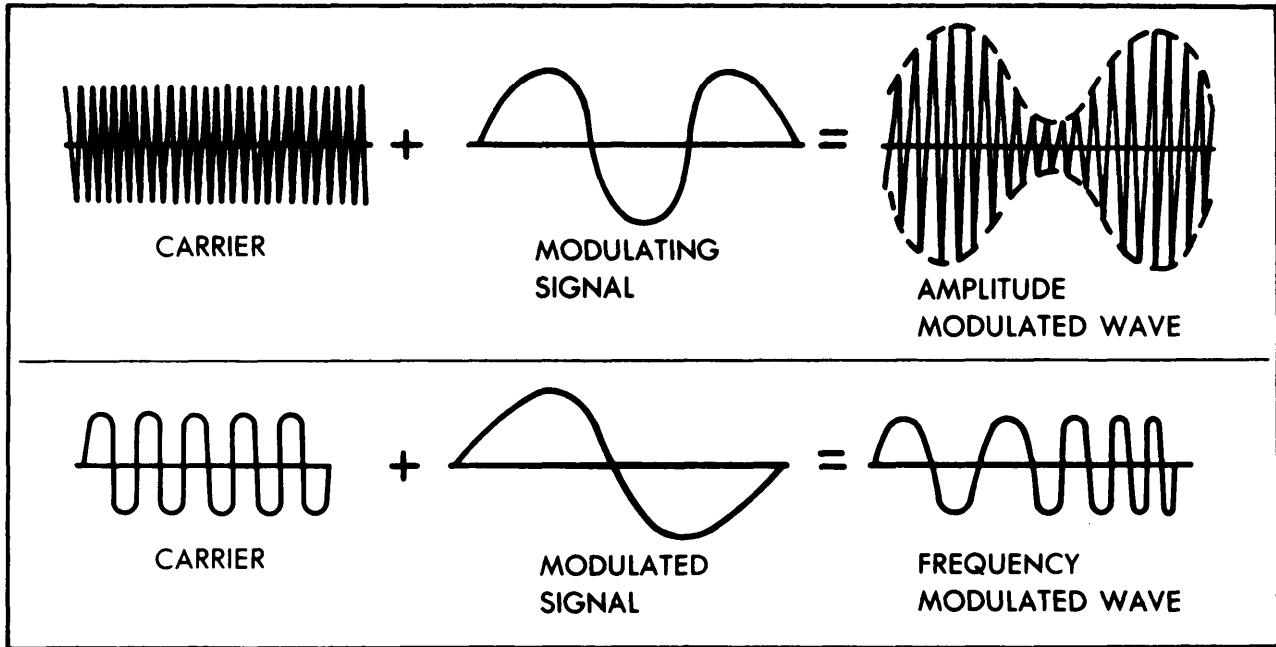

Figure 2-5. Amplitude, Frequency Modulation.

Rough terrain and inaccessible areas can be transversed more easily by relay stations than by telephone lines. In addition, since most of the equipment is located inside of buildings, the system is less susceptible to severe weather or bomb blast effects.

A tropospheric scatter system can also be used to extend UHF radio range. The atmosphere is made up of several layers that are constantly shifting but have sharply defined characteristics of temperature, moisture content, and refractive index. The index of refraction is the ratio of the velocity of a radio wave in free space to that of a wave in a different medium. The change in the index of refraction between atmospheric layers causes RF waves in the UHF band to bend. Most of the transmitted energy continues in the forward direction, but enough is bent or "scattered" back toward the earth to be usable (figure 2-7). Because of the large losses, the transmitter requires a large amount of power.

A troposcatter system can span up to 400 miles per link, where a microwave system would require many repeater stations to span the same distance. Just like a microwave relay system, the troposcatter system is capable of handling over 250 voice channels at ranges of 100 miles or less. But this number is reduced drastically as the range between links is increased. For example, at ground ranges over 300 miles, the system can handle only 12-24 voice channels.

One final method for increasing the range of UHF radio transmissions is to use satellites, either as a repeater system or passive reflector. Because of reduced signal losses, satellite links can provide ground ranges in excess of 750 miles. Figure 2-8 shows how a satellite relay system can greatly extend the range of a communication system over a troposcatter system. The resulting advantage is that one satellite could replace several ground-based troposcatter relay sites, effectively reducing the amount of equipment needed.

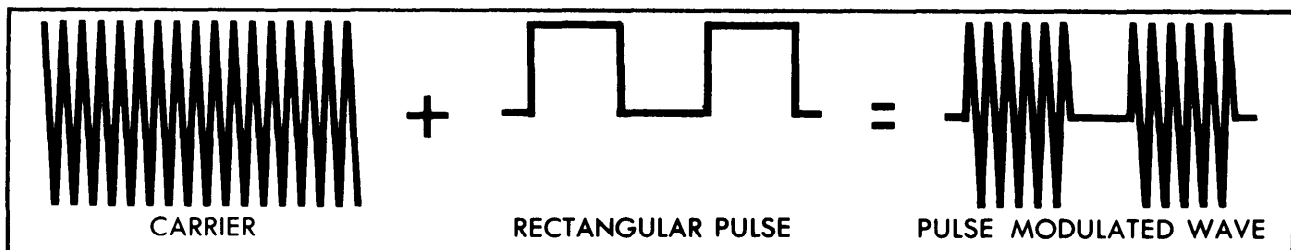

Figure 2-6. Pulse Modulation.

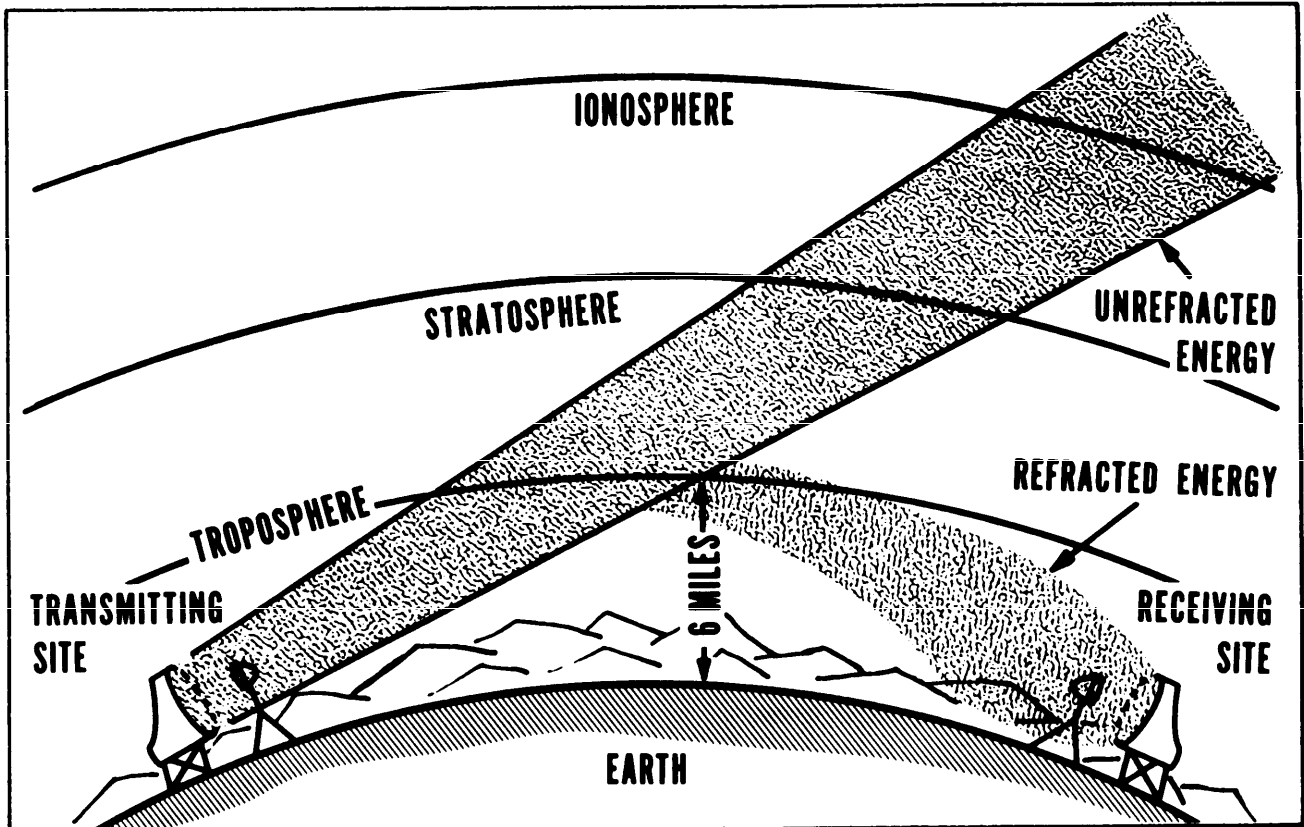

Figure 2-7. Forward Tropospheric Scattering Principle.

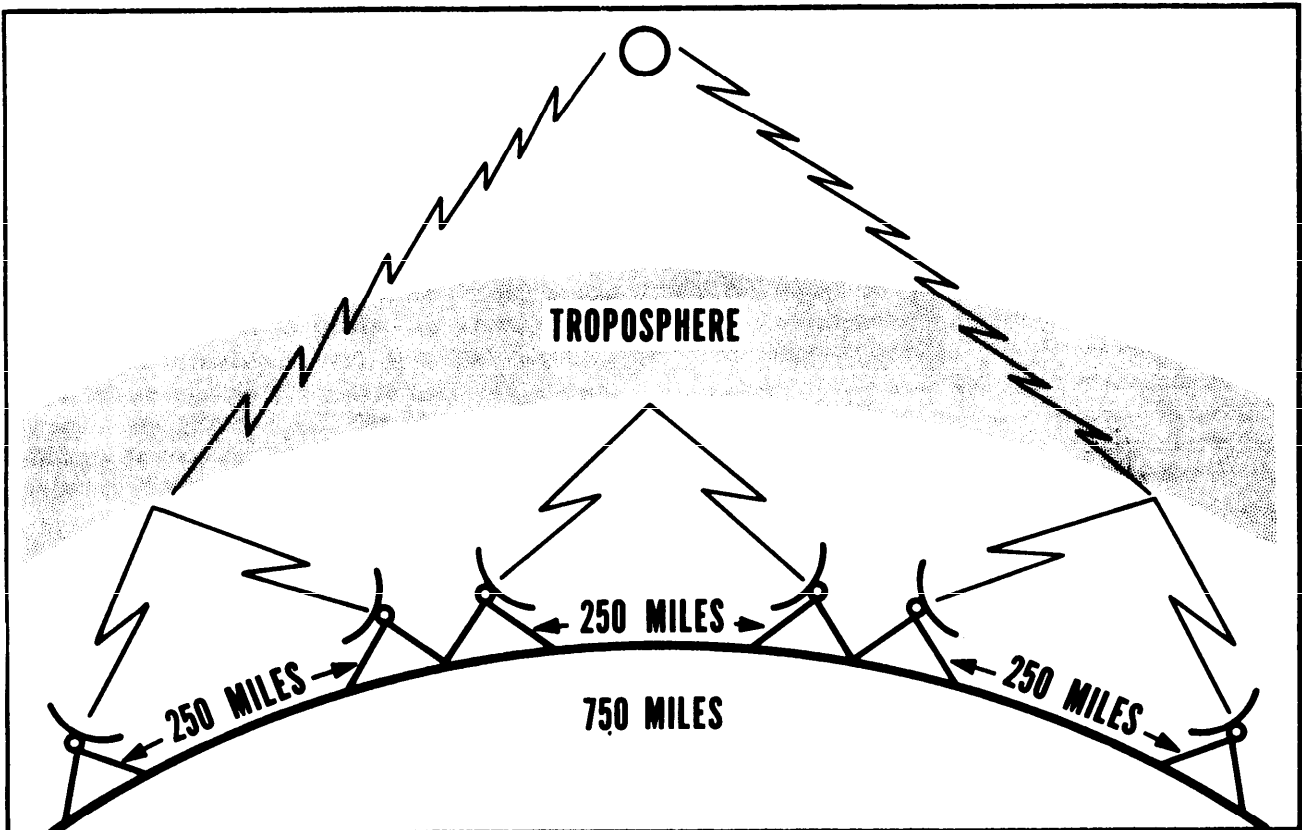

Figure 2-8. Troposcatter vs Satellite Communication.

BASIC RADAR PRINCIPLES

Radar is an electronic RF device used to detect a target and determine its range, azimuth, and (or) elevation. Basically, radar transmits EM energy, either as a burst or continuously, and receives a part of the energy reflected from targets within its range.

Range

A pulsed radar computes range to a target in much the same way as a person standing on the edge of a canyon determines how far it is to the other side by counting the number of seconds that elapse before hearing an echoed "hello" return. The elapsed time varies as a function of distance to the far side. Knowing that the speed of sound through air is approximately 1,000 feet per second, that person multiplies the total number of seconds that elapsed between the shout and the return echo by 1,000 feet to get the total distance the sound

traveled. By dividing that distance by two (since the sound traveled across the canyon and then returned), the resultant figure is the distance of "range" to the other side. In a pulsed radar, a short, powerful burst of EM radiation is sent out toward a target. As it leaves the radar, a beam of electrons begins to "sweep" (move at a fixed rate) across the face of the scope (cathode-ray tube). The burst of energy travels toward the radar. The reflected energy is received by the radar and displayed as a "brightening" of the electron beam on the scope.

Where this spot appears on the radar scope is directly related to the distance to the target. Since EM energy travels 1 nautical mile (NM) in 6.2 microseconds (μsec), energy traveling to a target 200 NMs away can go out to the target and return in less than $3/1,000$ of a second. Since this obviously is too fast to time with a stopwatch, a scope is used to determine range (figure 2-9). Energy traveling out 1 NM and back requires 12.4 μsec to make the complete trip. Therefore, a pulse

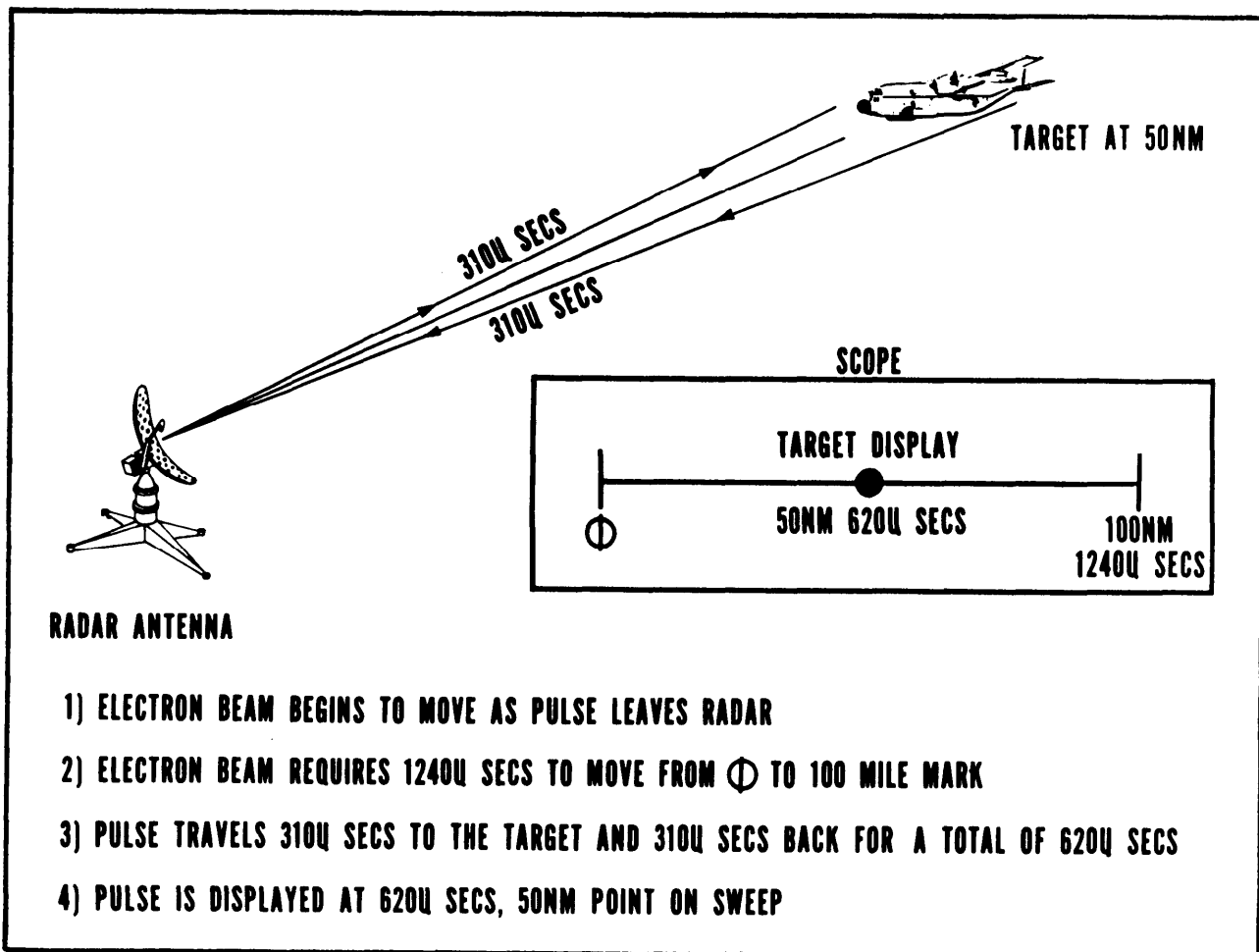

Figure 2-9. Determining Range.

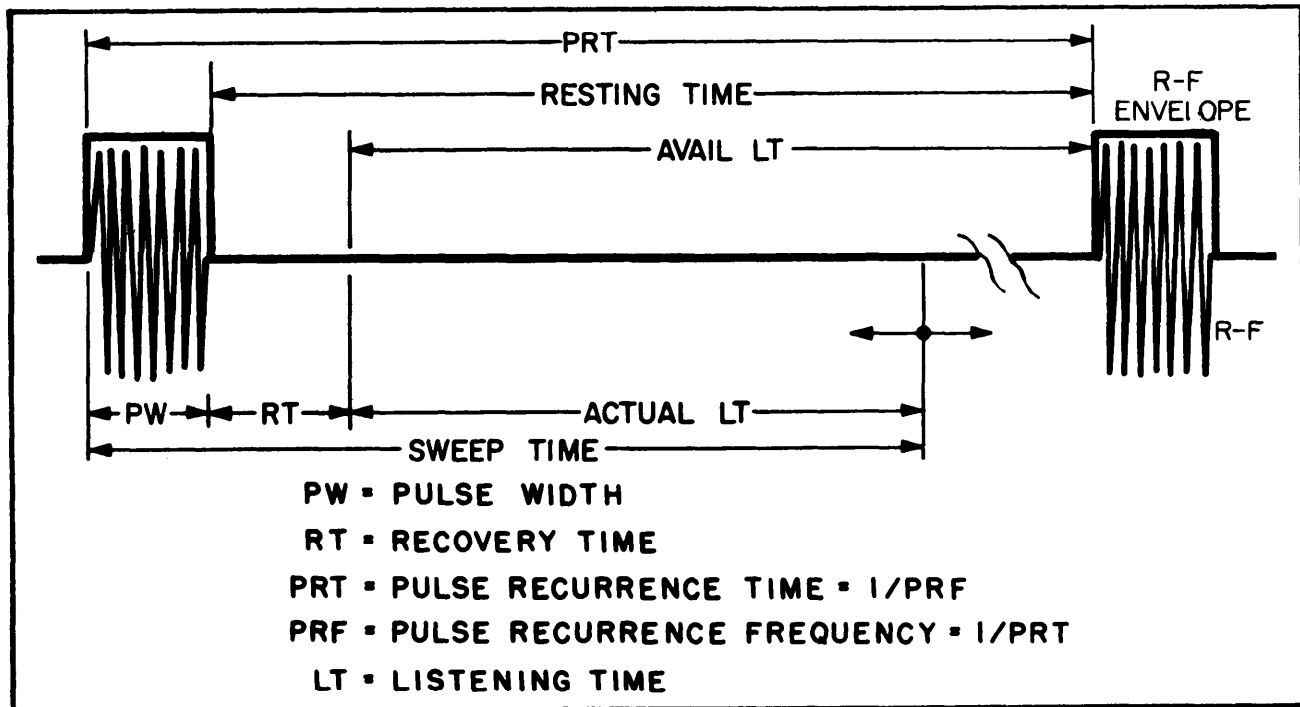

Figure 2-10. Transmissions and Reception Cycle.

which returns from a target in 12.4 μsec has traveled, by definition, 1 "radar mile." By dividing the number of microseconds elapsed by 12.4, range to a target can be accurately determined. (Range marks usually replace microsecond marks on the face of a scope. The marks are labeled in NMs rather than in microseconds for ease of interpretation.) Range then can be determined in exactly the same way we determine the width of the canyon, but at a much faster rate. In addition, a radar can detect useful information other than range to pinpoint a target's position. This other information is azimuth and (or) elevation.

Azimuth and (or) Elevation

Radars characteristically focus their transmitted energy into powerful beams of precise dimensions measured in degrees of beamwidth. By pointing these beams at a target and by referencing the antenna's position to some fixed reference, azimuth and elevation information may be obtained. Azimuth information is usually expressed in degrees that have been resolved relative to a true north reference. Elevation information is usually expressed in feet above a horizontal reference plane such as mean sea level (MSL). Specific beam shapes and dimensions are

dictated by a radar's use and will be discussed later.

Radar range, azimuth, and elevation have been discussed based on their determination from a single pulse. However, radar transmission and reception depend on a continuous series of pulses which have some interesting interrelationships.

Transmission and Reception

Two successive rectangular wave shapes (pulses) used to pulse modulate a radar transmitter are shown in figure 2-10. The time the radar is actually transmitting is known as pulse width (PW) or pulse duration (PD). The greater the amplitude of this pulse, the higher the peak power (P_{pk}) of the radar; the wider the PW with a given P_{pk} , the greater the average power (P_{av}). Both P_{pk} and P_{av} affect a radar's maximum detection range.

Pulse recurrence frequency (PRF) is the number of pulses generated per second. The reciprocal of PRF is pulse recurrence interval (PRI). PRI is the time between successive radar pulses and is a determinant of maximum radar range. Maximum theoretical range is the maximum range from which an echo can return before the next pulse is transmitted. This range is computed by the formula:

$$\text{Maximum Theoretical Range} = \frac{\text{PRI} (\mu\text{sec})}{12.4 (\mu\text{sec}/\text{NM})}$$

If the maximum theoretical range is too near the maximum obtainable range (based primarily on power), there is a risk of displaying a "second-time-around" echo. This occurs when the echo from a given pulse does not reach the receiver until the next pulse has already been transmitted. This return pulse would then be displayed on the radar scope at the range represented by the time difference between it and the second transmitted pulse rather than the first transmitted pulse (figure 2-11). For this reason, the maximum theoretical range is usually made substantially larger than the maximum detection range.

Rest time simply refers to the amount of time that the radar is not transmitting and, therefore, is allowing the transmitting tubes to cool or "rest."

The time immediately following transmission during which the receiver is unable to process returns due to receiver saturation and (or) the duplexer switching time is called recovery time (RT). The duplexer, which is an electronic switch connecting a single antenna to both the receiver and the transmitter, takes a finite amount of time to switch the antenna from the transmitter to the receiver and then back again. In addition, when a high-powered pulse is transmitted, a portion of

that pulse feeds into the receiver through the duplexer. This tends to saturate the sensitive radar receiver with the RF energy which prevents target returns from being seen. Since the radar cannot see a target return while it is either transmitting or recovering, the minimum theoretical range is dependent on these two times. For example, given a PW of 5.2 μsec and a recovery time of 1.0 μsec , the total time that the radar cannot receive is 6.2 μsec . This corresponds to a target slightly more than 3.1 μsec away. Minimum range, then, can be determined by the formula:

$$\text{Minimum Range} = \frac{(\text{PW} + \text{RT}) \times 984'}{2}$$

Minimum range for the above example, then, is

$$\frac{(5.2 + 1.0) \times 984'}{2} = 3050.4$$

feet. Therefore, a target must be farther away than this to be seen.

Available listening time pertains to that time when a radar can first detect a target after a pulse is transmitted and the time that the next pulse is sent out. Actual listening time is a function of the radar range selected by the operator and pertains to how much of the available listening time is actually used (figure 2-11).

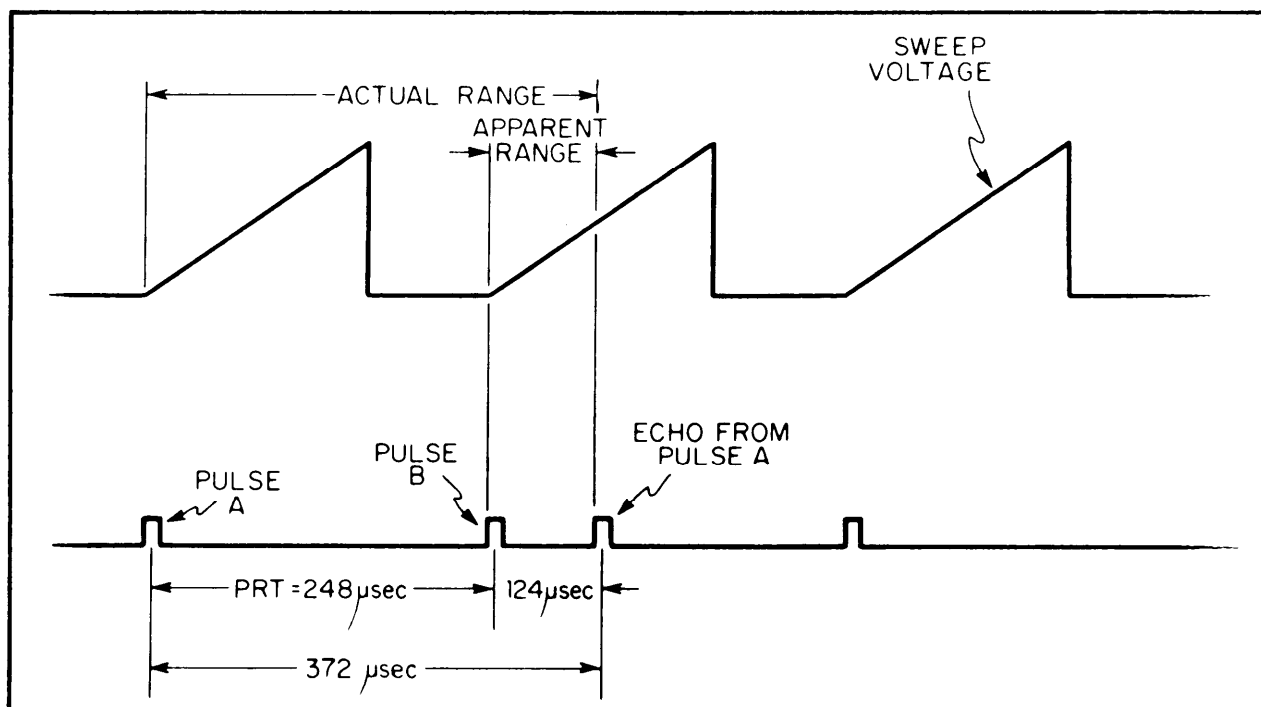

Figure 2-11. Second-Time-Around Echo.

Sweep time refers to the length of time the electron beam is made to sweep across the scope and corresponds to the time when the pulse starts to leave the radar and the end of actual listening time (includes both PW and RT (figure 2-11)).

What has been discussed so far affects the ranging capability of a radar. However, there are several other important considerations which influence a radar's ability to detect targets.

Resolution and Definition

Resolution and definition are two terms used to describe a radar's ability to detect targets. Definition pertains to the accuracy with which a certain aspect (range, azimuth, or elevation) is obtained, while resolution is a measure of the radar's ability to separate targets into individual returns that are close together in range, azimuth, or elevation.

Range resolution is determined primarily by PW and is the ability of the radar to separate two targets at the same bearing that are close together in range. A pulse in free space occupies a physical distance which is equal to the time of the pulse (in microseconds) multiplied by the speed of light (984 feet per μsec). If two targets are closer together than one-half of this physical distance (figure 2-12, example A), the trailing edge of the reflected pulse does not completely leave the first target before the arrival of the leading edge of the pulse reflected by the second target. Only when the two targets are physically separated by a distance greater than one-half of the space occupied by the PW will they appear as two targets (figure 2-12, example B). Range resolution can be calculated by the formula:

$$\text{Range Resolution} = \frac{\text{PW} \times 984'}{2},$$

where PW is measured in microseconds and 984 feet is the distance RF energy travels in μsec .

As can be seen in figure 2-13, examples A and B, azimuth and elevation definition of a radar are determined by beamwidth. For azimuth definition, it is determined by horizontal beamwidth (HBW), while for elevation definition, it is determined by vertical beamwidth (VBW). Generally speaking, the wider the beamwidth or the farther the target is from the antenna, the poorer the resolution.

Radiation in Free Space

The relationship of the factors affecting the actual maximum range of a radar set is defined below in the free space radar equation. This equation is derived by removing all influencing factors outside the radar equipment and the target (in effect, locating both the equipment and the target some distance apart in space and free of reflections from the earth's surface). Although this is a theoretical constraint, it provides an excellent insight to the basic factors affecting actual range.

Because the effectiveness of a radar set depends on the detection of a weak signal returned from a distant reflecting object, the factors which control the strength of the echo are of prime importance. To work out the radar equation, the properties of the transmitting and receiving antenna systems must be known and so must the reflective characteristics of the target. In addition, the losses encountered in radiation through space must be computed. The following equation shows the maximum range of a radar system. The terms included in the radar equation are as follows:

$$S = \frac{P_t G_t \sigma A_r}{(4\pi)^2 r^4}$$

S is the echo pulse power received at the radar receiver. Power (P_t) is the peak power times the pulse duration. Gain (G_t) is the gain of the transmitting antenna in the direction of the target. " σ " is the coefficient of target reflection, also known as "radar target cross-sectional areas." A_r is the capture area of the receiving antenna. " r " is the range to the target.

A full explanation of the radar equation, to include all of the contributing factors that are involved in each of its values, is beyond the intended scope of this pamphlet; however, a general examination of its major elements will provide a basic understanding of what affects the strength of a radar's received signal.

If an antenna could be designed to radiate equally well in all directions, its resultant radiation pattern would be spherical in shape. The power density (watts of radiated energy per cm^2) on the surface of that sphere is thus calculated. This is done by dividing the total surface area of the sphere (expressed mathematically as $4\pi r^2$, where " r " is the radius of the sphere) into the total power (P_t), expressed in watts, that the transmitter could produce. The expression for the power at any point on the surface of the sphere would then be:

$$\text{Power Density} = \frac{P_t \times \text{Watts}}{4\pi r^2 \text{ cm}^2}$$

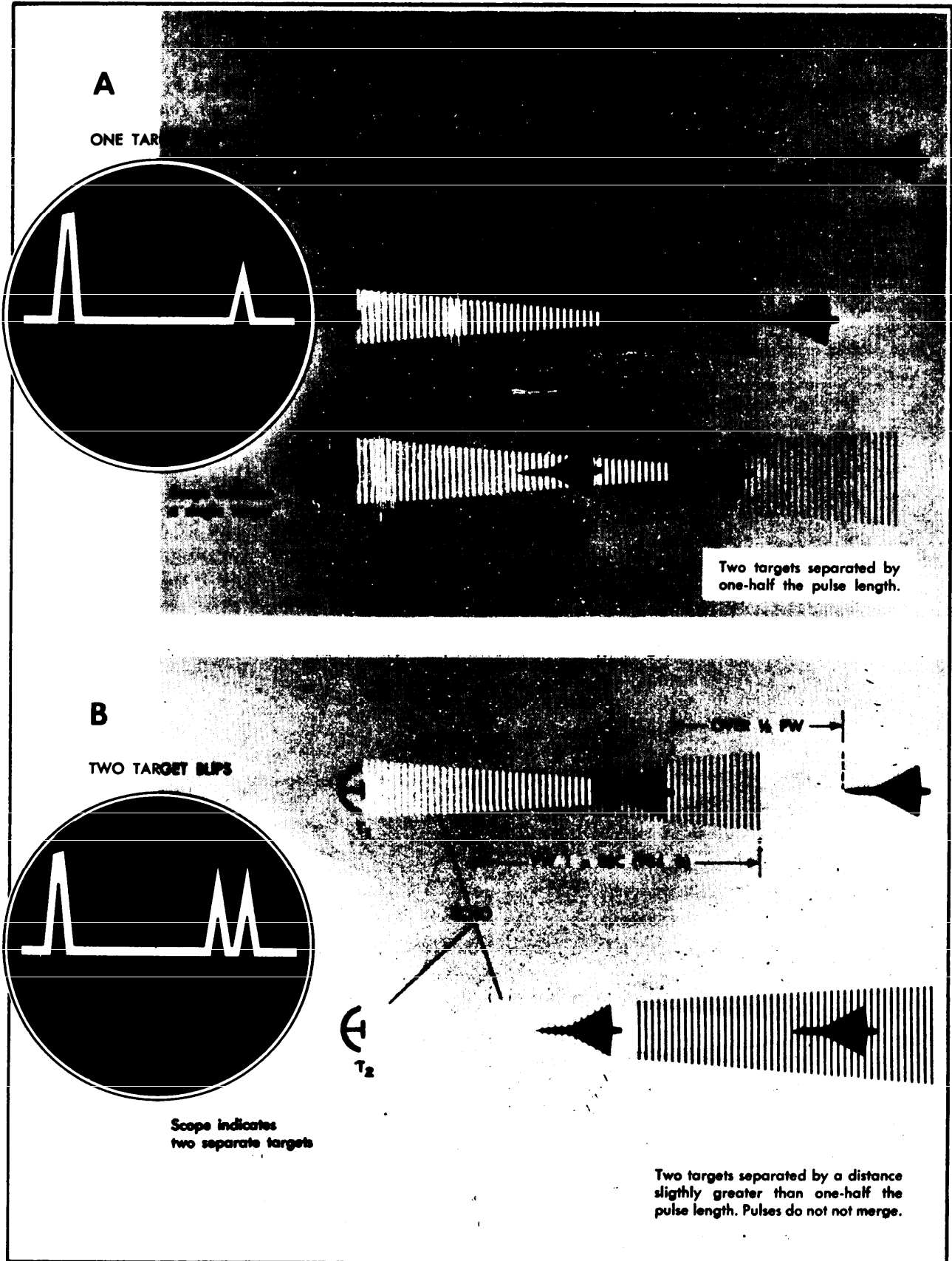

Figure 2-12. Pulse Radar Range Resolution.

Unfortunately, even if such an antenna could be designed, it would be totally unsuitable for radar use since its beamwidth would provide neither azimuth nor elevation information; therefore, a practical antenna must be brought into the equation. A practical antenna differs from the above mentioned theoretical antenna only in terms of gain. The gain of an antenna is merely an expression of that antenna's ability to direct and focus energy in a particular direction. As shown in figure 2-14, example B, the power at some distance "r" from the antenna can be expressed as:

$$\text{Power Density} = \frac{P_t \times G_t}{4\pi r^2}$$

where G_t equals the gain of the transmitting antenna.

Since a beam of some angular dimension physically diverges as it goes outward from an antenna, by the time the beam reaches most targets, its cross-sectional area is rather large. In addition, this cross-sectional area is quite large with respect to the target's size (figure 2-14, example C). Therefore, only a small portion of the total power in the radar beam can be reflected

toward the antenna since only a small area of the beam is intercepted by the target. The rest of the energy continues on through space and is dissipated unless it is reflected by other targets. The reflectivity of the target (based on target material and the amount of power reflected by the target) can be expressed as:

$$\text{Power Density} = \frac{P_t \times G_t \times \sigma}{4\pi r^2}$$

However, this power is diminished again by $4\pi r^2$ as the energy radiates away from the target, so the energy reaching the radar's receiving antenna is:

$$\text{Power Density} = \frac{P_t \times G_t \times \sigma}{(4\pi)^2 r^4}$$

Finally, the radar antenna intercepts only a small portion of the reflected energy due to its small size compared to the cross-sectional area of the reflected energy. This interception area or "capture area" is represented by A_r as shown in figure 2-14, example D). The entire equation, then, for the amount of reflected energy "S" received from a target at range "r" is:

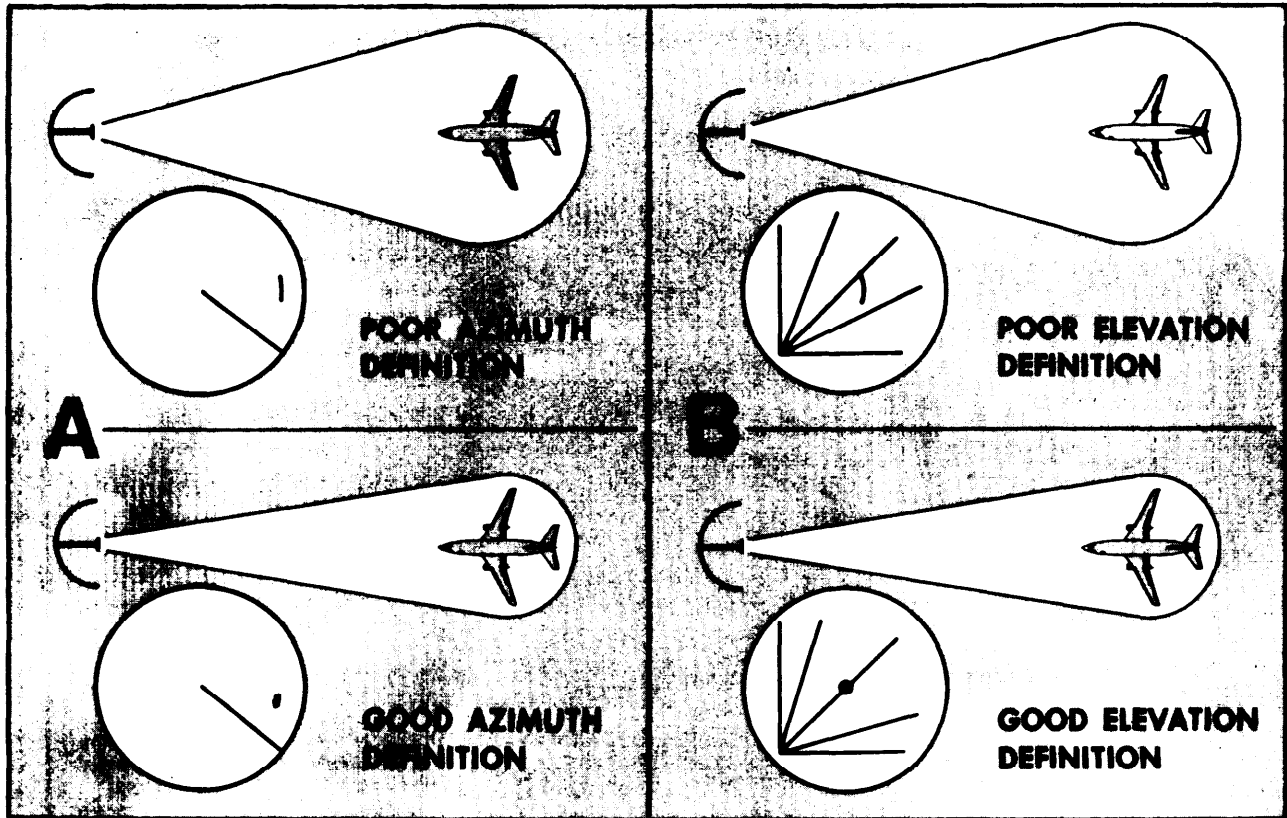

Figure 2-13. Azimuth/Elevation Definition.

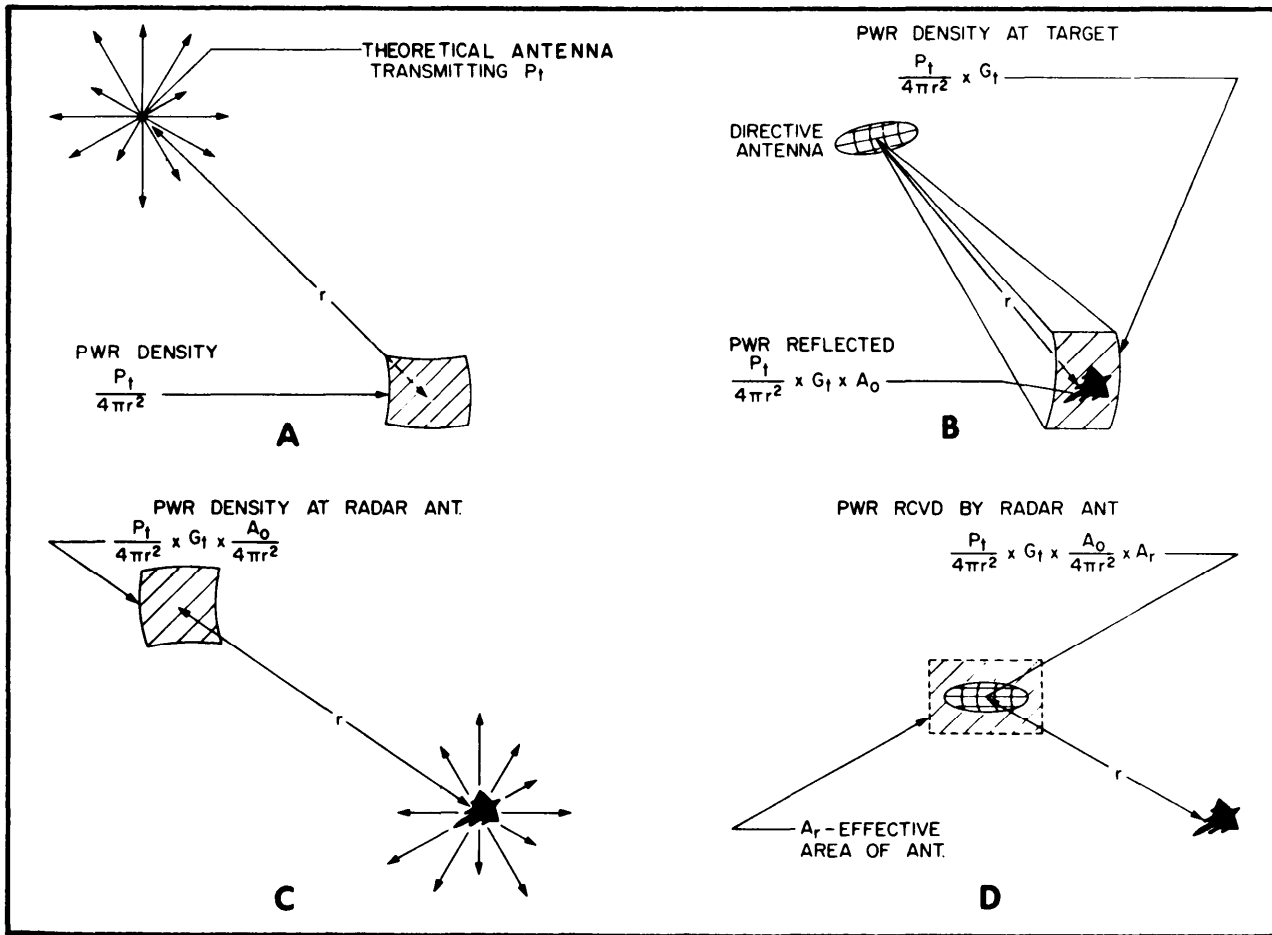

Figure 2-14. Free Space Radar Equation.

$$S = \frac{P_t \times G_t \times \sigma \times A_r}{(4\pi)^2 r^4}$$

This equation illustrates when megawatts of power are transmitted; only microwatts may be received as reflected target information. However, there are other factors that vary daily, seasonally, and with location, which may cause less than optimum or nonstandard propagation.

Nonstandard Propagation

Radar waves are not always propagated in the same way and, therefore, do not always achieve the same range characteristics.

Interference patterns occur in low frequency radars because of surface reflections. Figure 2-15 shows the paths of direct and reflected waves. As illustrated, strong lobes are produced by the addition of these two waves. The nulls between

strong lobes are a result of cancellation of the direct and reflected waves.

The strong lobes increase the range of the radar. The nulls between the lobes are a disadvantage since targets may be lost when passing through these parts of the radiation pattern.

Range errors can be caused by adverse weather conditions. Temperature and humidity in certain conditions can bend radar radiation earthward and allow the radar to detect targets slightly beyond the optical horizon. However, atmospheric conditions are extremely variable and, at times, much of all of a radar beam is bent upward and dissipated. This weakens the RF echo reducing the effective range of the radar. Therefore, radars are usually "horizon limited" in their ability to detect targets. At other times, the beam is bent downward and a duct is formed between the earth's surface and the refracting layer of atmosphere. In such instances, energy dissipation of the radar wave is low, so the echo strength and range of target detection is greatly increased.

The Beacon Principle

A normal radar transmits short bursts of microwave energy and determines target azimuth and range by detecting the echoes of these bursts that are reflected from target aircraft. Since the transmitted bursts must travel from the radar to the target and back, the power received is inversely proportional to the fourth power of the distance. In a beacon system, the transmitter (which is called an "interrogator") sends a pulse of microwave energy to the target, but instead of being reflected by the target, it is received by a transponder in the target. The transponder is a combination transmitter and receiver. When the transponder receives the pulse from the radar's interrogator, it responds by transmitting a return pulse on a different frequency. The radar beacon system on the ground receives this return pulse and processes it to obtain target range and azimuth just as it would normal video. One big advantage of the beacon system is its greater range capability. The interrogator pulse reaching the target can be much weaker than a normal radar pulse since it does not have to be reflected to the ground radar. It only has to be powerful enough to trigger the transponder. The power rating of the transponder itself is somewhat limited since it must be airborne, but the propagation is only one way; therefore, the power in a pulse from a transponder, even though its power is limited, can

easily be made much greater than that in a radar echo. One disadvantage of the beacon system is that the target must carry a transponder designed to operate with the ground equipment. Another disadvantage is the possibility that hostile forces could use the transponder to their advantage. However, secure techniques can be employed in a beacon system to minimize hostile exploitation.

Beacon systems have been invaluable for the command and control of friendly aircraft. Improvements and additional functions ensure the continued utility of the beacon system.

Basic Radar Components

The essential components of a pulsed radar system are depicted in figure 2-16. Each component serves a specialized function necessary to the proper operation of the radar. These essential components include:

1. A DC power supply to provide the energy required for the system.
2. A timer to provide the radar's PRF and to synchronize the scope with the transmitted pulse.
3. A modulator to form the basic rectangular pulse characteristics.
4. An RF generator/oscillator having the higher powered capability to convert the modulator's rectangular pulses to pulses of RF energy.
5. An antenna assembly to radiate and receive RF energy. This assembly contains a duplexer (an

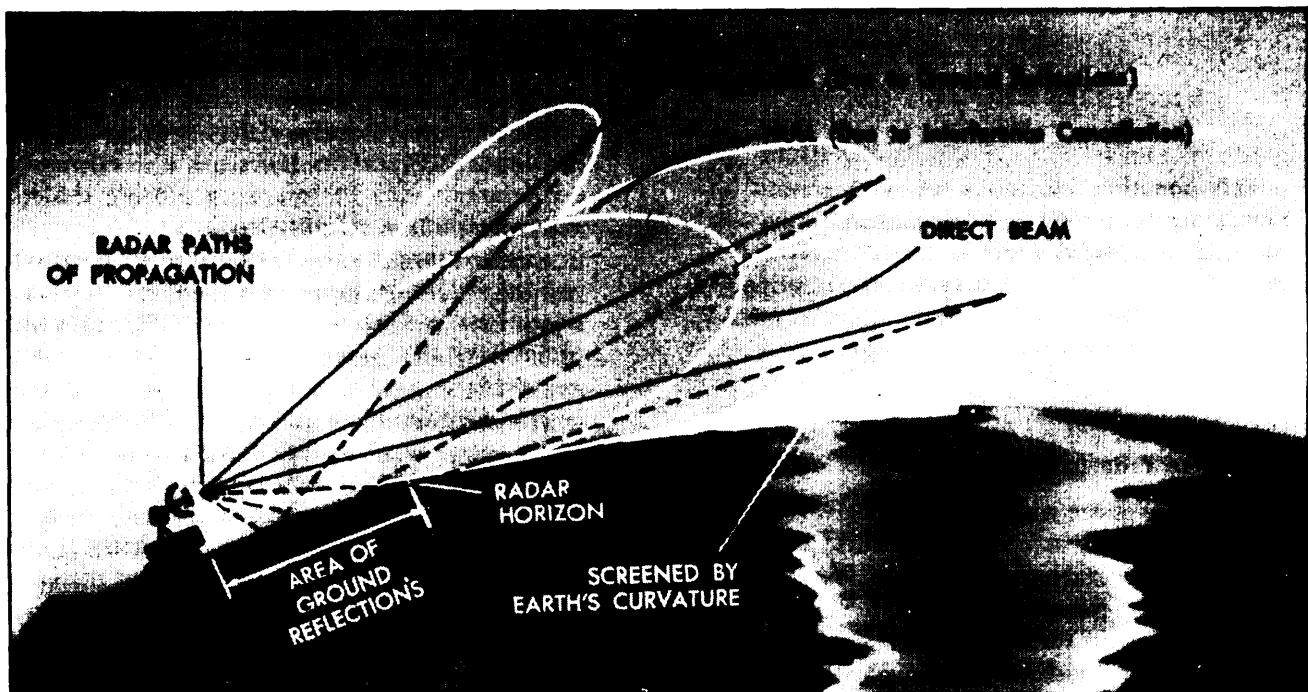

Figure 2-15. Nonstandard Propagation.

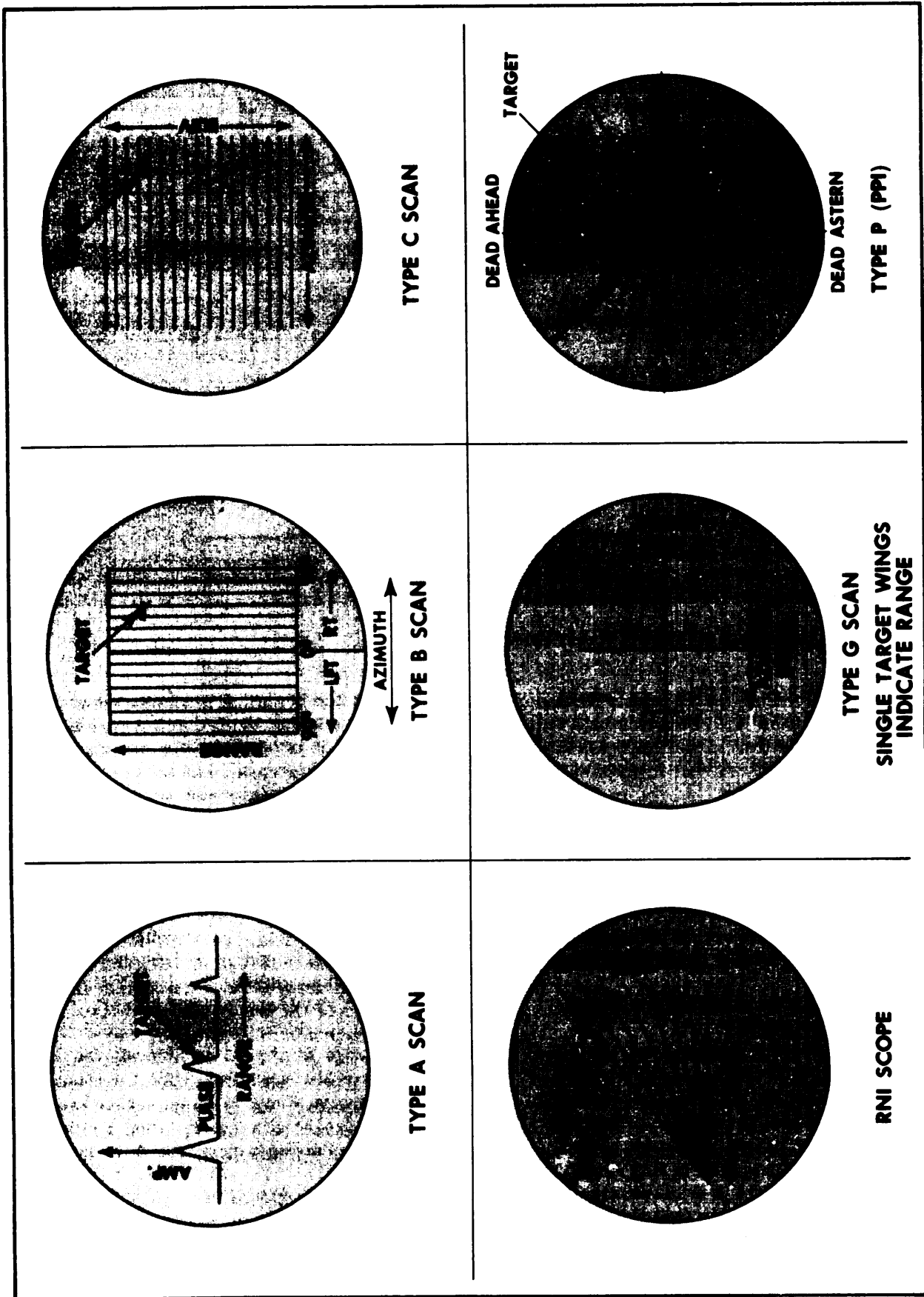

Figure 2-17. Sample Radar Scopes.

sweep trace produces a fan-shaped indication with the vertex at the lower left of the indicator. The target appears as a bright spot indicating the range and elevation. The RHI scope is commonly used with HF radars and a modified RHI scope is also used for ground-controlled approach (GCA).

Type G. Modifications of the basic type C presentation were made to include range estimation in addition to azimuth and elevation. When a target is picked up by a radar scan of the area, the set locks onto the target. As the target approaches or gets closer to the radar, the side "wings" in the indicator become larger. Both the gun and antenna are maneuvered until the target spot is centered on the indicator. When the "wings" reach a predetermined size, the target is within gun range.

Type P. The type P indicator presentation (commonly known as a PPI or plan-position indicator scan) is probably the best known type of radar presentation. It represents a map picture of the area scanned by the radar beam. The center of the cathode-ray tube represents the position of the transmitter and the trace is synchronized with the antenna rotation to provide target azimuth indications. The distance from the center indicates the range to target.

Parameter Determination

In radar design, the first consideration is the intended range of that radar. A PRF is then selected that will offer the optimum balance between available power and the greatest number of reflected pulses per scan of the antenna. (The greater the number of pulses returning from a target, the more readily detectable that target becomes.) The radar's PRF is controlled by the timer.

After choosing the PRF, the PW of the radar is determined by the average power and range resolution required. (The greater the PW, the higher the average power, but the poorer the range resolution.) Next, an antenna is designed which offers the HBW and VBW best suited for the radar task. For example, if the radar is to provide accurate azimuth information, a narrow HBW and a wide VBW are required. On the other hand, if accurate elevation information is desired, a narrow VBW and wide HBW are required to provide good altitude discrimination.

Several important factors go into the selection of the radar's RF. Since wavelength increases as frequency decreases (expressed by the formula

$$\lambda = \frac{c}{f},$$

where λ equals the wavelength, c is the speed of light, and f is the frequency in Hertz), the lower the transmitted frequency, the larger the reflector must be for any given degree of focusing. (This tends to make low frequency radars for AIs rather impractical.) In addition, different frequencies propagate through space with differing amounts of attenuation. Some frequencies (for example, 1,000 MHz to 2,000 MHz) permit energy to propagate long distances with ease. Other frequencies (for example, 8,000 MHz to 10,000 MHz) permit energy to propagate far shorter distances even with increased transmitter power. Thus, a radar's RF in most cases is a compromise between the low frequency and long range of a large reflector, and the high frequency and short range of a small reflector.

The final parameter in radar design is the rate at which the radar's antenna will search space. The process of searching space with the radar antenna is called "scanning," and is often referred to as "sweeping" in a circular scanning radar and "nodding" in a height-finder radar (HFR). The two types of scanning are discussed below under "Basic Radar Types." In either type, the amount of time the radar takes to complete one full cycle is called its "scan duration." Scan duration depends on the number of "hits per scan" (the number of pulses reflected by a target as the radar beam crosses it during one full scan) required by the radar scope in order to display a target. Most radars require between 15 to 20 hits per scan to obtain sufficient information to display the target. The factors that determine the number of hits per scan the radar actually receives (from a planning standpoint) are the PRF, explained above, the antenna's beamwidth, also explained above, and the antenna's scan duration. Generally speaking, the lower the PRF (as required for long range) and the narrower the beamwidth (as required for good resolution), the longer the scan duration must be to satisfy target display requirements.

Since each individual radar's parameters is chosen on the basis of the radar's intended use, radars with similar parameters and use may be categorized by threat potential relative to directing weapons against an aircraft.

Basic Radar Types

Radars are of three general types: indirect threat, direct threat, and nonthreat radars.

Indirect Threat Radars

Radars in this group are important since they can alert the air defense system and may be used

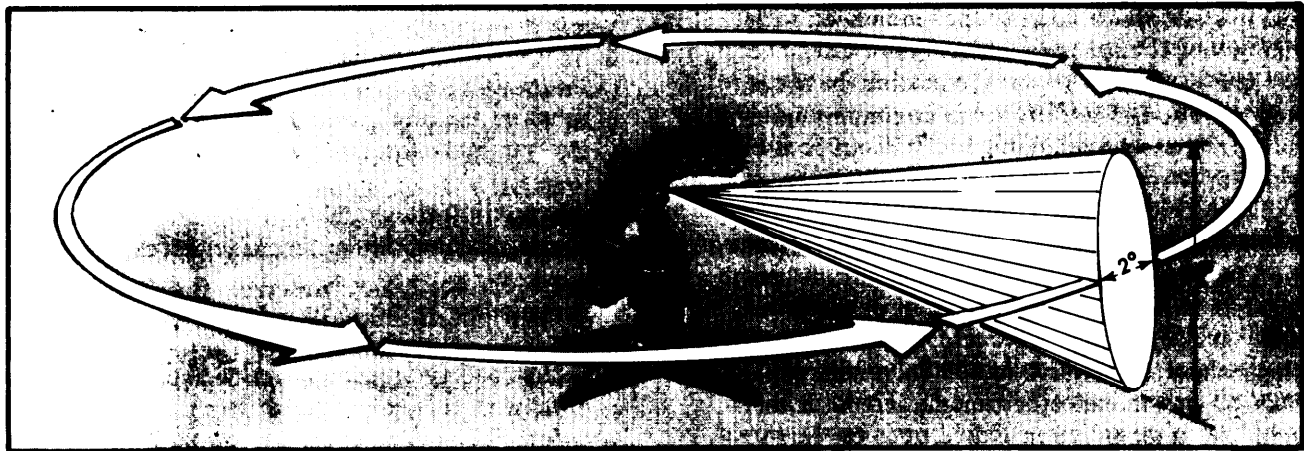

Figure 2-18. Circular Scan.

to position AIs and (or) pass information to SAM sites and anti-aircraft batteries.

Early Warning Radar (EWR) or Long-Range Radar (LRR)

The EWR is a high-powered radar used for long-range detection of aircraft. Its main purpose is early detection, with secondary emphasis on accuracy. Hence, it is generally characterized by relatively long PWs (greater than 6 μsec), low PRFs (100 to 400 pulses per second), and RFs in the range of 100 MHz to 3,000 MHz. The long PWs allow the transmission of very high average power. The low PRF allows very long listening times and ranges up to 300 NM are common.

The scan type used with EWRs is circular. A narrow vertical fan-shaped beam is rotated in a full circle around a fixed vertical axis, as shown in figure 2-18. Typically, the beam is focused to about 2 degrees in azimuth and to about 10 degrees in elevation. This yields acceptable azimuth resolution and good altitude coverage. The resulting vertical fan-shaped beam is rotated slowly with a typical scan duration of 12 to 20 seconds. This slow rate, as mentioned earlier, is necessary to provide the required number of hits per scan. These radars are found in the lower frequency ranges and require large reflectors to focus their energy.

Acquisition Radars

A variation of the EWR, known as an acquisition (acq) radar, is associated with ground weapon systems such as AAA or SAMs. This radar is similar in function to the EWR since it provides range and azimuth data which is used as preliminary information for ground weapons systems. However, when compared with EWRs,

acq radars have shorter PWs (typically 1 μsec), higher PRFs (typically 500 to 800 pulses per second), and narrower beamwidths, but like the EWRs, they employ circular scan. Range resolution is improved as is azimuth resolution, and since the scan duration is reduced to around 5 seconds, the data collection rate is much faster. However, with improvement in accuracy comes a sacrifice of total power. The maximum theoretical range drops to around 150 NM and the actual range detection is less because of the limited power capability. These radars normally operate at high frequencies to facilitate focusing of the beam into a more precise pattern.

Height-Finder Radars (HFR)

As the name implies, an HFR is designed to provide altitude information, and it usually operates with an EWR. The EWR operator detects a target at some range and azimuth, gives the information to the HFR operator, and the height finder is then turned to the approximate azimuth of the target where it begins to "nod" up and down. The vertical sector scan is the most distinctive characteristic of an HFR (figure 2-19).

The height finder is similar in many respects to the EWR except that the beam shape must be modified to provide a narrow beam (typically 1.5 degrees) in the vertical plane and a wider beam (typically 4 degrees) in the horizontal plane. This narrow, horizontal fan-shaped beam is then nodded up and down in an arc about -2 degrees and + 32 degrees.

To develop the required beamwidth, the antenna must have a fairly large vertical dimension. It must also "nod" up and down at a fairly rapid rate and, therefore, should be as small and light as possible. These requirements dictate a

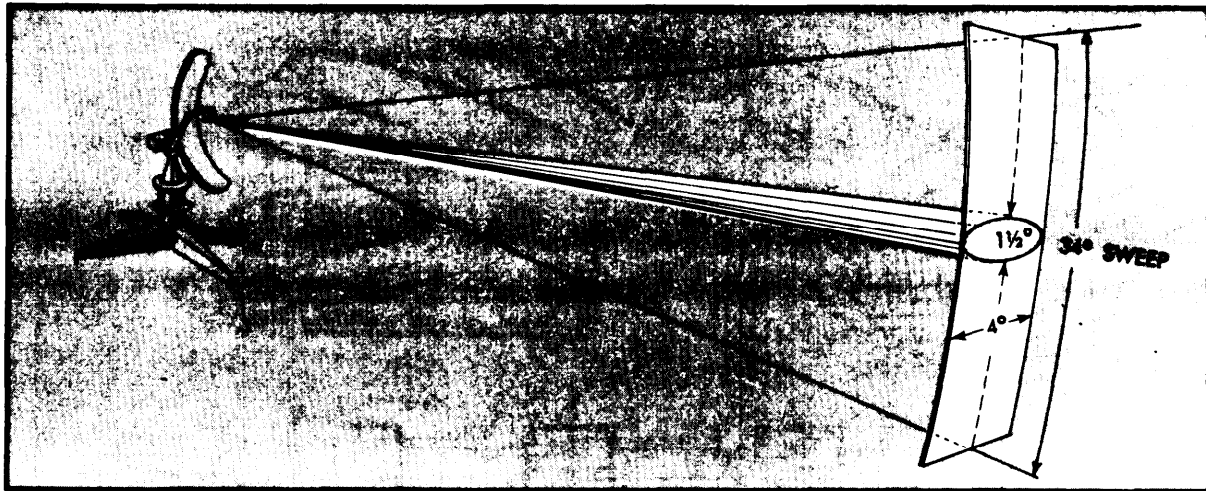

Figure 2-19. Vertical Sector Scan.

height operating frequency, or small wavelength, so the antenna may be physically small. Typical height-finder frequencies can range from 2,000 to 10,000 MHz.

As mentioned above, height finders are often used with EWRs, and together they form a GCI site. A ground-based radar controller uses radars and UHF communications to guide AIs to intercept a hostile aircraft. To do this, the operator must have range, azimuth, and altitude information on the targets and the interceptors. Altitude data is just as critical as range and azimuth. For this reason, the height finder must be accurate. To obtain sharp slant range resolution, which affects both horizontal range and altitude above the ground, height finders usually have PWs of approximately 2 μ secs.

Since the radar of the height finder should be comparable to that of the EWR, the PRF will

generally be in the same range. A PRF of about 300 pulses per second (PPS) is typical.

Ground Controlled Intercept (GCI) Capability

An EWR and HFR equipped radar site can position a target in range, azimuth, and elevation and, given the necessary communications, vector an AI to the target area. Any radar or combination of radars which can accurately position a target in all three dimensions and direct the intercept of that target is said to have a GCI capability.

V-Beam Radar

The V-beam radar derives its name from the shape of its transmitted beam (figure 2-20). Two fan-shaped beams similar to the EWR beam are swept concurrently. One of the beams is vertical.

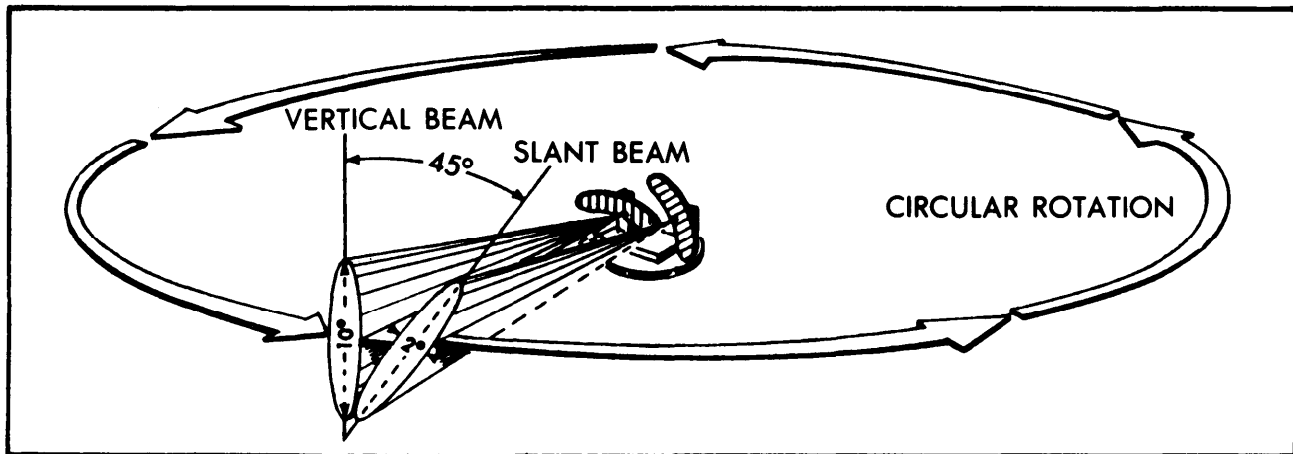

Figure 2-20. "V" Beam Scan.

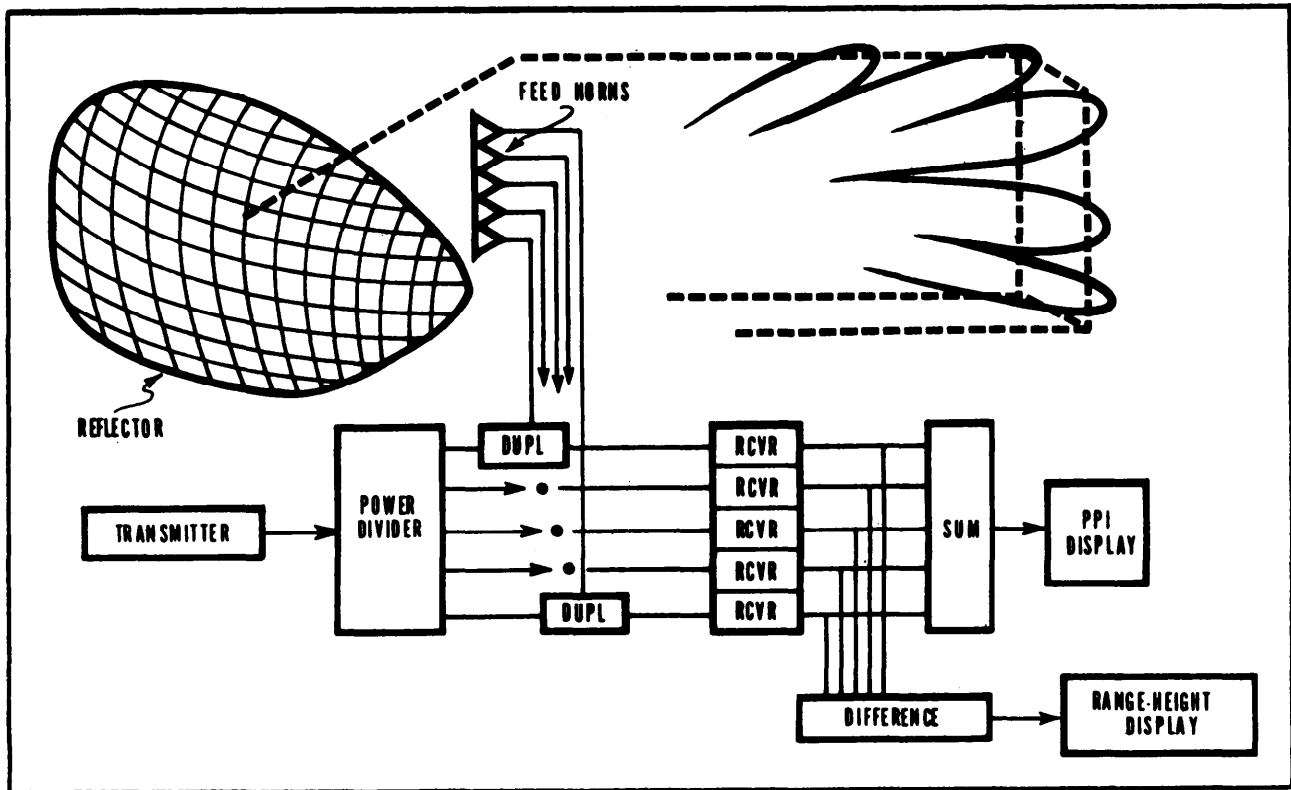

Figure 2-21. Stacked Beam Radar.

as in the EWR, and the other one is at some convenient angle. In addition to range and azimuth information from the vertical beam, a time difference between intercept of echoes from the two beams on a target tells how far up the "V" the target is. This gives an indication of altitude. The accuracy depends on the beamwidth and the timing accuracy of the radar.

Stacked Beam Radars

A stacked beam radar may also be considered a GCI radar. It employs a vertical stack of fixed elevation pencil or horizontal sector beams which continuously rotate 360 degrees in azimuth (figure 2-21). Elevation information is obtained by noting which beam contains the target echo. Just like the combined EWR and HFR equipped site and the V-beam radar, a stacked beam radar will provide a position in range, azimuth, and elevation, giving it a GCI capability.

Direct Threat Radars

Direct threat radars are of primary concern to all aircrew members since they supply information directly to weapons capable of destroying their aircraft. These radars can detect, track, and continually feed updated aircraft position infor-

mation into weapon systems computers. The computers automatically aim a gun or track a missile to the target.

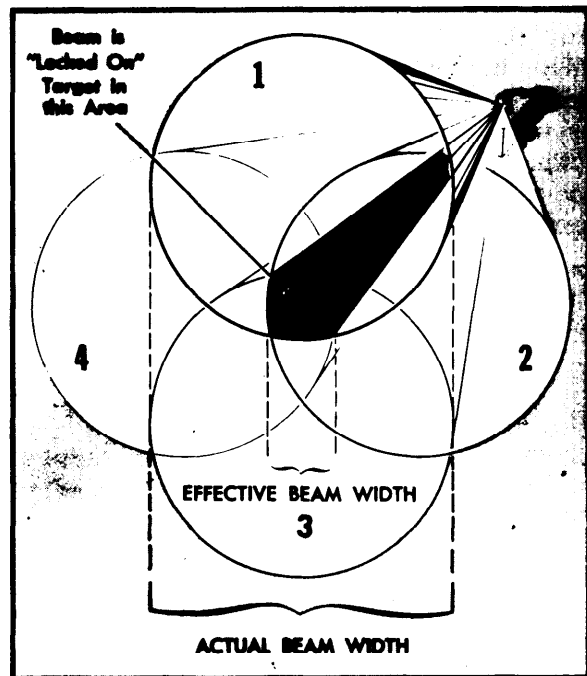

Figure 2-22. Conical Scan.

These radars provide much greater accuracy and speed of data gathering than the systems previously discussed. The necessity for improved accuracy becomes evident with an examination of the dimensions of either an EWR or HFR "resolution cell." A resolution cell is a block of airspace, the dimensions of which are expressed in terms of range, elevation, and azimuth, and depend upon radar PW and BW. All targets within the cell will be displayed by the radar as a single target. Assume that a target is being intercepted at 100 NM. Using typical parameters of an EWR-HFR combination (EWR: PW equals $6.0 \mu\text{sec}$, HBW equals 2 degrees; HFR: PW equals $2 \mu\text{sec}$, VBW equals 0.9 degrees), the dimensions of the resolution cell are approximately 1,000 feet deep by 20,000 feet wide by 9,000 feet high. Although general target location can be determined using such radars, a much more accurate determination of location will be needed to position a tracking radar on the target. The precision radar with two modes of operation—acquisition and track—accomplish this. The following paragraphs discuss such radars.

Conical Scan Radar

The conical scan radar is a relatively low powered, precision radar. In conical scanning, a radar beam is made to describe the shape of a cone in space. The apex of this cone is located at the antenna, and the coverage angle of the cone is less than twice the width of the radar beam normally radiated from the antenna. Figure 2-22 shows this radiation pattern. The circles show four of the possible beam positions described in space as the antenna moves through its 360-degree scan cycle. The beam overlaps itself at the center creating an effective beamwidth (black area) narrower than the original beam. A target in this area sends a constant amplitude echo back to the radar from all beam positions and the radar is said to be "locked-on" to the target. If the target moves out of the black area, returns of varying amplitude are sent back to the radar as the beam rotates through one complete cycle. A comparison of signal strengths creates an error signal and causes the antenna drive unit to move the antenna in the direction of the strongest return.

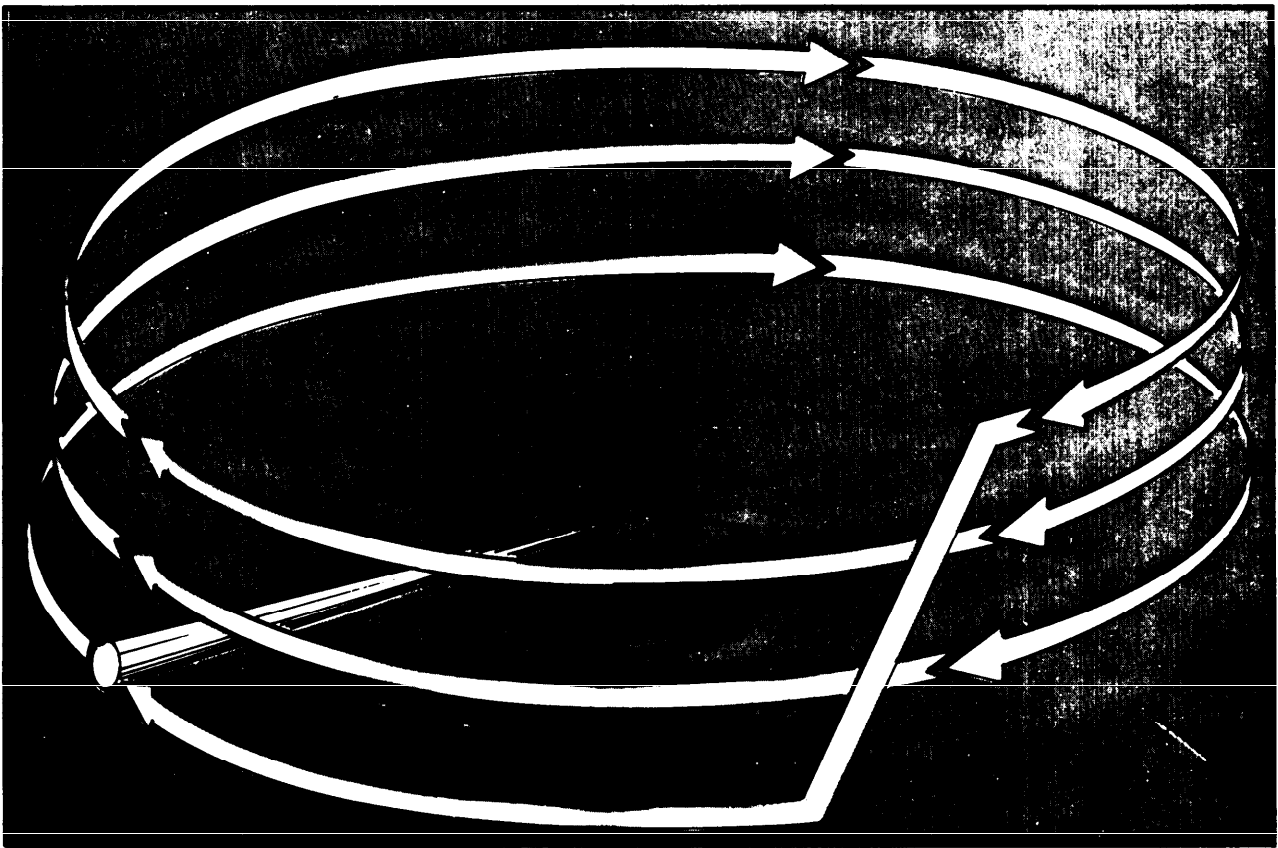

Figure 2-23. Helical Scan.

To isolate one target and increase the speed of gathering data, the conical scanning radar usually operates with a high PRF (1,000 to 2,000 PPS), a narrow PW (0.5 to 1.5 μ sec), and highlights the target with its pencil beam. Both azimuth and elevation data are received by the radar every revolution of the beam (approximately 1,800 rpm). This means that the maximum data gathering is about 30 times per second. The RF is usually between 2,500 MHz and 20,000 MHz to facilitate beamshaping. The actual beamwidth can be reduced to less than 2 degrees with an effective beamwidth less than one-half of a degree.

The small beamwidth of a conical scanning radar makes it ideal for tracking but renders it relatively useless for acquiring the target. Ground-based conical scanning radars must use either a helical or spiral search pattern. These scans allow a large area to be searched with a pencil beam (figure 2-23). As soon as the target is found, the radar transitions into the conical scanning track mode described above.

Transition time between acquisition and track may be reduced by the use of a Palmer scan. A Palmer scan is the superposition of conical scan onto one of the acquisition scans. A Palmer-helical scan is shown in figure 2-24.

Airborne Interceptor (AI) Radar

An AI radar which uses conical scan for its tracking mode employs either raster or spiral scan for target acquisition. Raster scan is a horizontal sector that has abrupt changes in elevation at the end of each sector level (figure 2-25). Actually, the only differences between the conical scan used for AI operation and ground-based operation are the RF and the type of acquisition scan. An AI radar system usually operates above 8,500 MHz to reduce the physical size of the transmitter and receiver components, especially the antenna. Spiral scan (figure 2-26) moves the beam around a central axis in the shape of a cone and follows and ever-increasing cone angle.

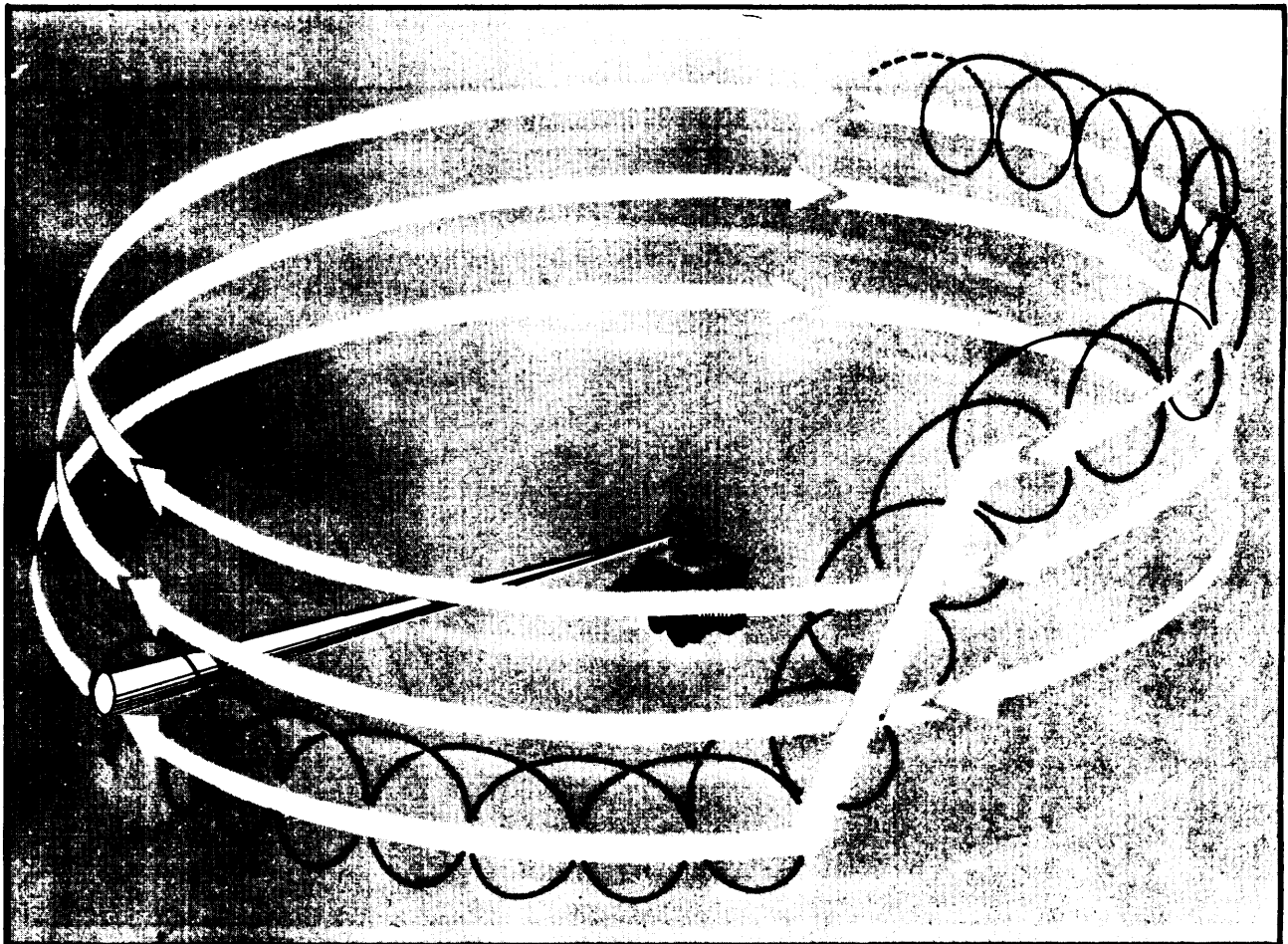

Figure 2-24. Palmer-Helical Scan.

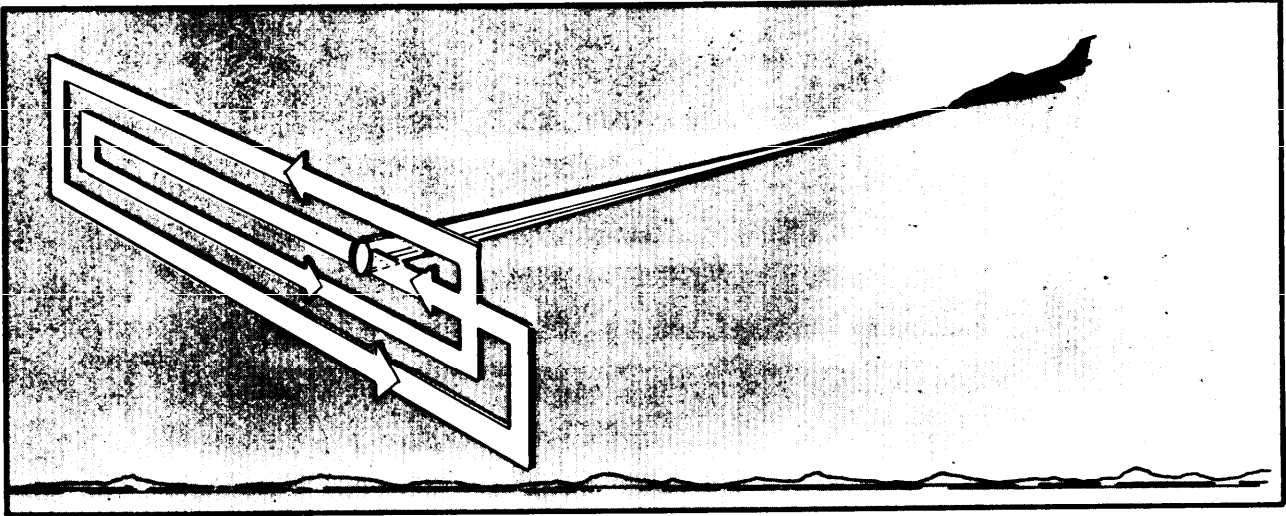

Figure 2-25. Raster Scan.

The spiral scan pattern is the same for ground-based and AI radars. Raster scan serves the same purpose as spiral scan. Again, Palmer-raster scan may be used to decrease the transition time from the search to track mode of operation (figure 2-27).

Monopulse Radar

The monopulse radar gets its name from the fact that each pulse from the target yields a new azimuth and elevation correction signal. It does not rely on pulse-to-pulse amplitude variations as

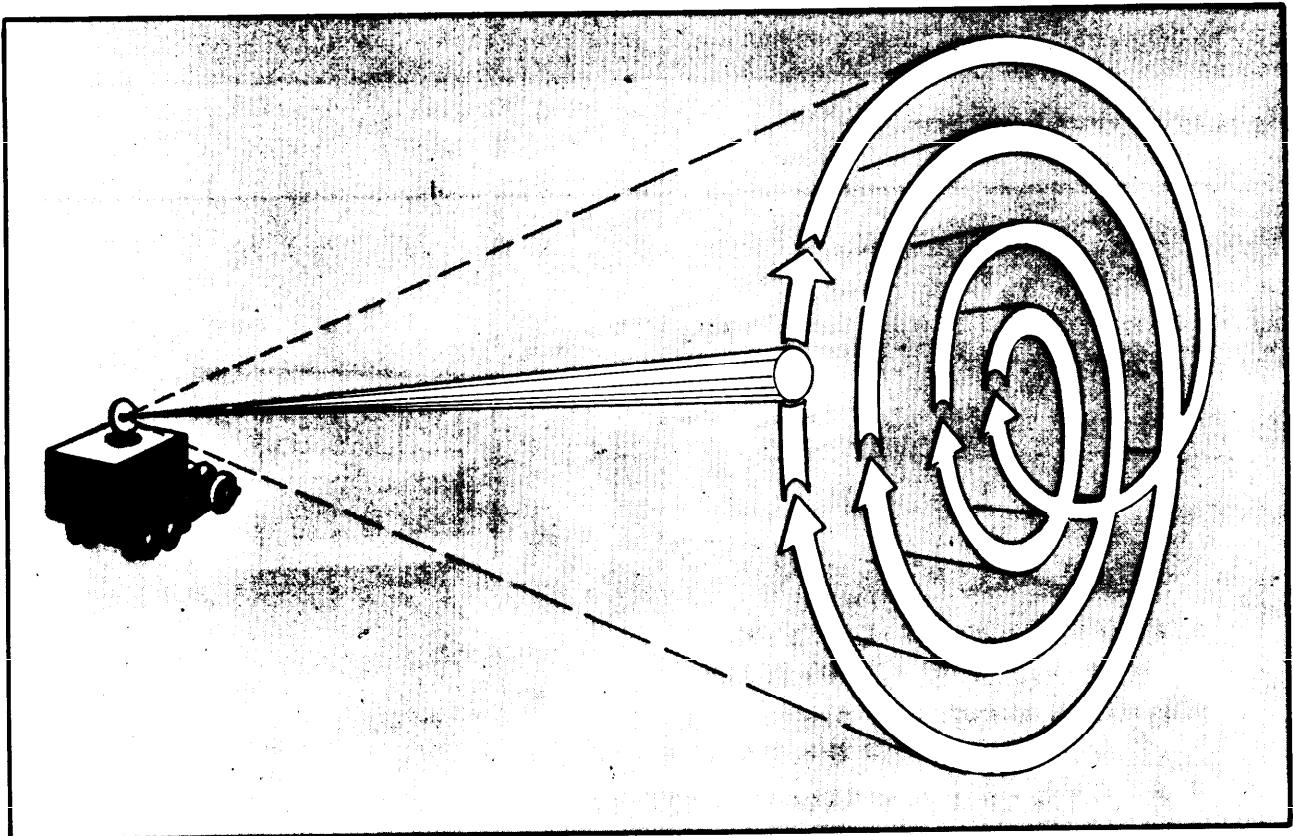

Figure 2-26. Spiral Scan.

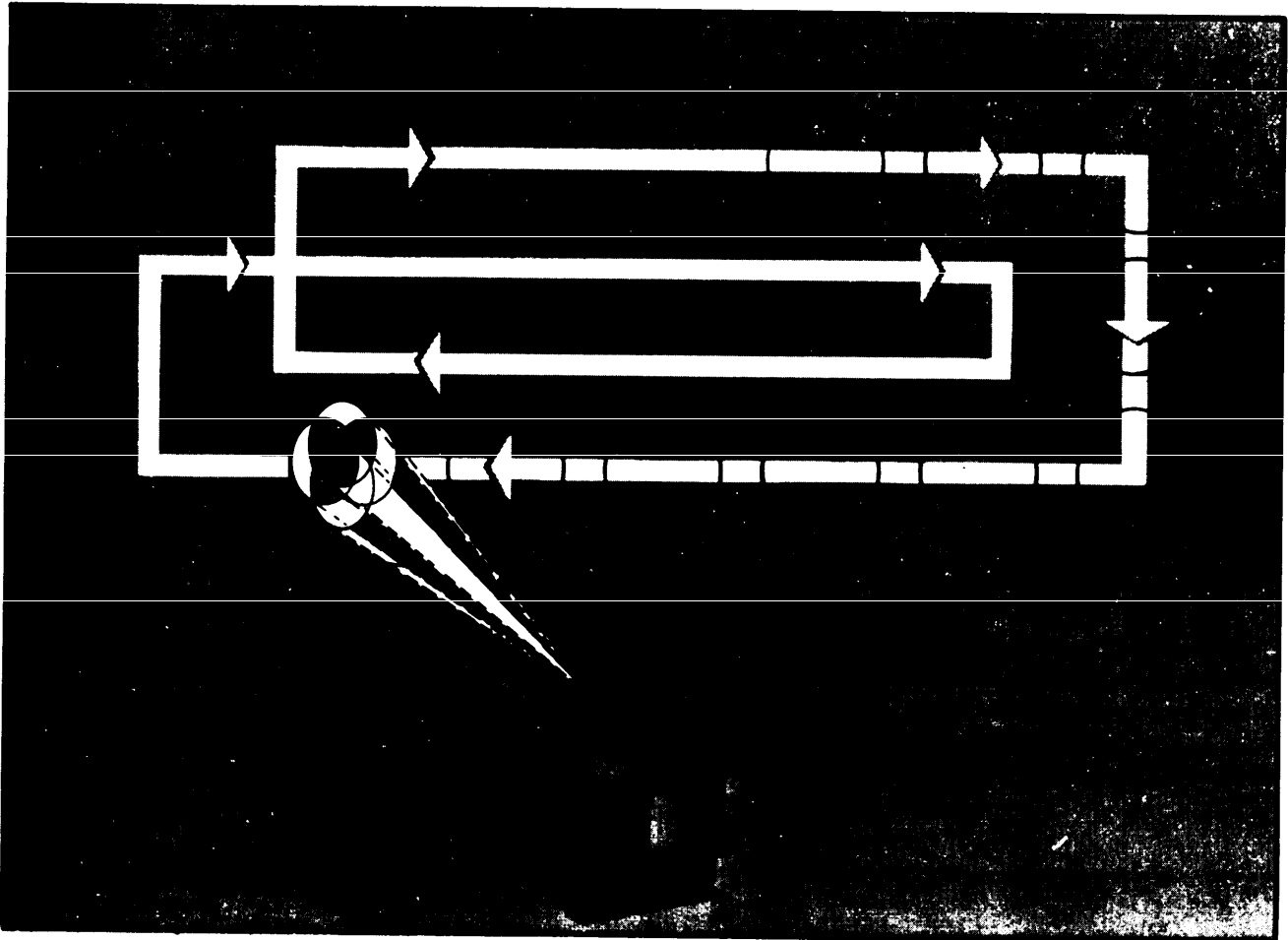

Figure 2-27. Palmer-Raster Scan.

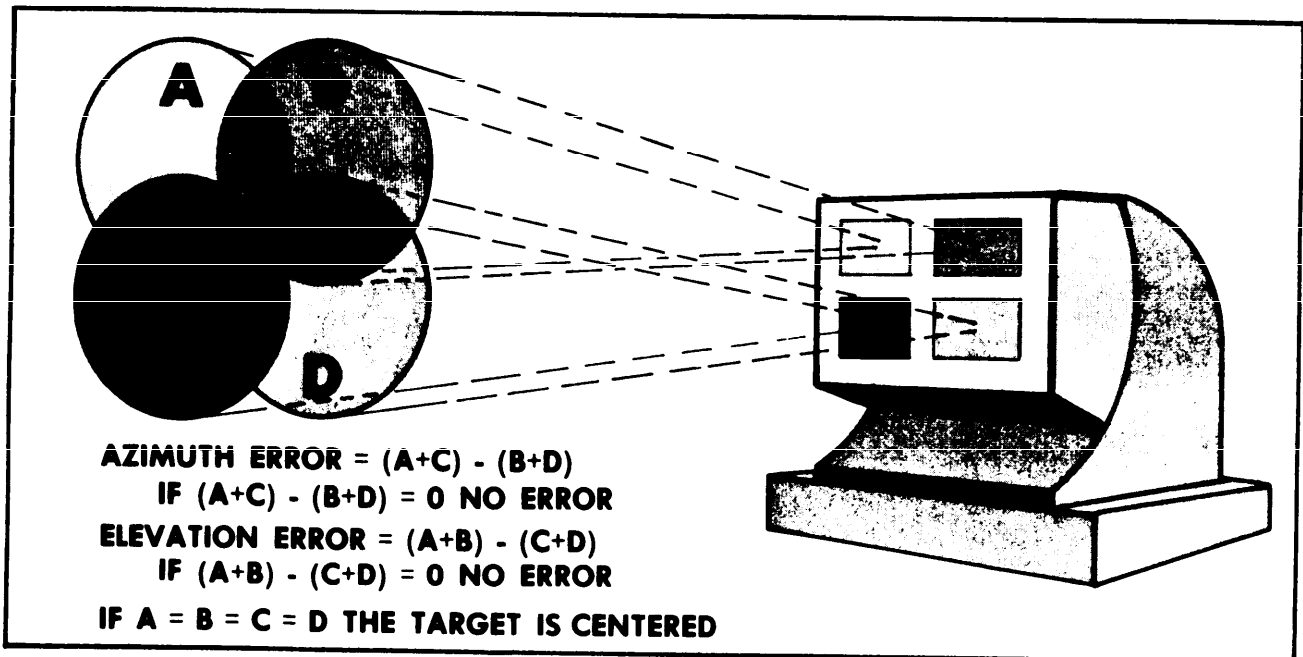

Figure 2-28. Monopulse Radar.

does conical scan. Instead of rotating a single beam around the target to determine error signals, the monopulse system transmits, using one RF, and receives pulses in four different antennas, as shown in figure 2-28.

The azimuth and elevation correction signals required are determined by the relative pulse amplitudes from the four antennas: A, B, C, and D. If the target was on center in azimuth but above center in elevation, the sum of the energy from antennas A and C would be equal to the sum of the energy from antennas B and D; but the sum of the energy from antennas A and B would be larger than the sum of the energy from antennas C and D.

The circuitry used for monopulse radar is much more complex, and its construction and physical layout are much more critical than with the conical scan. However, monopulse has a distinct advantage in that pulse-to-pulse amplitude variations caused by noise or deliberate ECM will not affect its tracking ability. Also the error signals are updated much more rapidly since a complete new position is obtained with every pulse. A typical monopulse radar might be used to guide missiles, but monopulse radars are also used as target tracking radars for ground-based anti-aircraft weapons and AIs. Monopulse radars are capable of tracking only one target at a time.

Track-While-Scan (TWS) Radar

Thus far, all the tracking radars discussed provide continuous tracking data on one target. We will now examine the TWS radar which provides sample data on many targets. The simplest example of a TWS is an operator sitting at a PPI scope with a grease pencil marking the track (course) of an aircraft. If we replace the grease pencil with a computer and simultaneously maintain tracks of several hundred aircraft, we would have a system similar to the Federal Aviation Administration's (FAA) system. This is a system that requires azimuth, range, and elevation (provided by transponder) to provide aircraft spacing, a basic TWS system.

A TWS system can also be used with target tracking radars (TTRs). In this case, azimuth, range, and elevation information must be accurate and updated several times per second without assistance from the target (no transponder). One way of doing this is to use a phased array radar to acquire the target and computer to maintain the tracks of many targets.

The most common TWS radar operates on a different principle than either the conical scan or monopulse systems and is not really a tracking radar in the true sense of the word. However, it does provide complete and accurate position information and is commonly used for guidance of SAMs. The TWS radar uses two separate beams produced by two separate antennas on two different frequencies. One beam is very similar to a height finder except that the beamwidth is narrower for sharper definition, and it is scanned at a more rapid rate. This beam determines target evaluation and range. The other beam is identical to the first except it sectors through a horizontal arc instead of a vertical one. The second beam determines target azimuth (relative to a zero reference azimuth in the center of the sweep) and range. Both beams are illustrated in figure 2-29.

The angle and range of all targets in the coverage of the radar are displayed on two scopes. One scope is calibrated in azimuth and range, and the other in elevation and range.

Operators position cursors over the returns from the target and the missile so as to feed position information on both to a computer. The range, elevation, and azimuth information on the target and missile is then processed by the computer to obtain a guidance signal. The guidance signal is transmitted to a receiver in the missile to make "in-flight" corrections right up to the moment of warhead detonation.

Lobe on Receive Only (LORO)

LORO is a mode of operation that may be adopted by several existing tracking systems. This mode generally consists of transmitting on one antenna system and receiving the reflected energy on another antenna system. The transmitting antenna does not scan, but merely highlights the target with constant RF energy. However, the receiving antenna scans the reflected signal and obtains the target's angular position. The advantage of this system is that it conceals the scanning or lobing mode of the tracking system and does not allow the application of countermeasures that depend on a known scan or lobe pattern.

Passive Tracking

The direct threat radars just discussed provide range, azimuth, and elevation data to a fire control system. However, it is possible to operate these systems passively; that is, scan the antenna without radiating. If a target is radiating (jamming) on the radar's frequency, the fire control

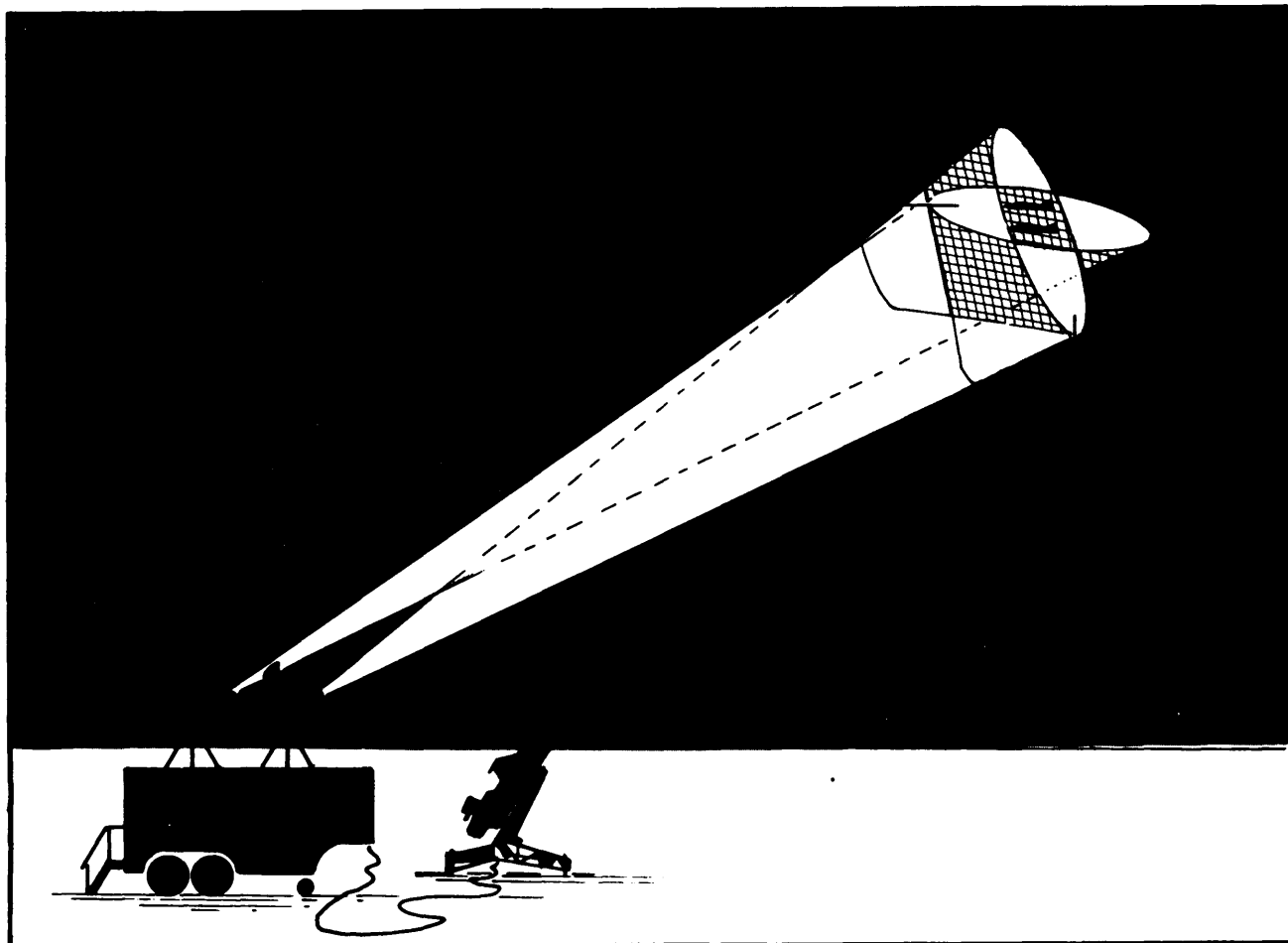

Figure 2-29. Track-While-Scan Radar.

system can receive sufficient azimuth and elevation data, and some weapons may be fired effectively using only passively obtained information. This mode of operation is a threat because it is difficult to detect. Since no energy is transmitted, an aircrew member has no warning that tracking is taking place, and jamming techniques may or may not be effective since the radar's scan type is concealed (see chapter 5).

Nonthreat Radars

From an aircraft defense standpoint, nonthreat radars include navigation, missile detection, and mapping radars. Aircrew members rarely come into direct contact with these radars; however, a knowledge of their existence and use will complete the subject of basic radar systems, capabilities, and applications.

Airborne Navigation Radars

These are high frequency systems (above 8,500 MHz) that provide a map-like display of terrain

below the aircraft. When used with an associated computer, Doppler radar, and astrotracker, the airborne navigation system is extremely accurate and reliable. These radars can take several forms ranging from circular-scanning, long-range radars to forward sector scanning radars.

Synthetic Aperture Radar

One way to improve a radar's angular definition is to use a large antenna. A large antenna is more capable of focusing its transmitted energy into a narrow beam, thus resulting in a smaller beam-width. Unfortunately, there are limits to the size of antennas an aircraft can carry. Synthetic aperture radars overcome this limitation by artificially increasing the antenna's size, giving excellent angular definition.

The synthetic aperture concept is similar to a large linear array antenna. With a linear array, several radiating elements are placed in a straight line. The signal is transmitted and received simultaneously in all elements. A synthetic

aperature radar does the same thing sequentially. A single radiating element is flown in a straight line and transmits at appropriate points along the route. The returns are stored for processing as they are received. The result of synthetic aperature is a very narrow beamwidth without a large antenna.

The first synthetic aperature systems were used in the late 1950's using optical signal processors. The information had to be stored photographically so processing took place on the ground. Because of this time lag, its usual application was in high quality ground mapping.

With the advent of high speed integrated circuits in the 1970's, it became possible to process video signals in the air in real time. Now synthetic aperature radars can be used for navigation, bombing, and many other uses. The capabilities of synthetic aperature radars seem limited only by the speed of airborne digital systems.

Space Surveillance Radars

Space surveillance radars are low frequency radars (UHF band) with PWs greater than 2,000 μ sec and peak power levels greater than 3 megawatts. These radars can detect targets with a 1 square meter cross-section out to 2,000 NM, and can analyze targets by their roll and tumble rates.

Airport Surveillance Radar (ASR)

ASRs are located at most airports, and are usually used to control departing and approaching aircraft and as acq radars for GCAs. They are relatively precise, short-range radars with PWs normally less than one μ sec and PRFs greater than 1,000 PPS. Scan durations are usually 3 to 4 seconds. Range is on the order of 50 to 90 NM. Frequencies of operation are usually between 2,700 and 2,900 MHz.

Doppler Radar

In 1842, Christian Johann Doppler noticed that the pitch (frequency) of an audio tone was higher when the listener was moving toward the source. The reason for this, he discovered, is that an observer moving toward the source would intercept successive accoustic wavefronts at a greater rate than a stationary observer and, therefore, would hear a higher pitched sound. The same effect occurs with EM radiation, such as light, radio, and radar waves. A radar moving toward a source of EM radiation will measure a higher frequency than is actually transmitted. Doppler radar, which exploits these frequency

shifts, has found widespread use in everything from airborne navigating to fusing explosive projectiles, such as missiles and AAA shells. Whether continuous wave or pulsed, Doppler is an extremely important radar concept.

Continuous Wave (CW) Doppler Radar

An elementary system using the principles of Doppler shift is depicted in figure 2-30. Such a system consists of a transmitter, receiver, indicator, and antennas. RF energy is radiated by the transmitter, reflected off of a target and returned to the receiver. The radiated frequency is then compared to the frequency of the returned energy. The difference in frequency, called Doppler shift, is amplified, processed, and sent to an indicator as a target velocity. The basic CW Doppler system transmits a wave of constant amplitude and frequency, and because of this, range information cannot be determined. The radar cannot recognize the time lag between the transmission and reception of radar energy. If it were possible to time the echoes, the information could be used to compute range to the target. Another limitation is that velocity is measured relative to that of the transmitter; therefore, objects moving at the same velocity as the transmitter cannot be detected. It is also difficult for CW Doppler radars to generate enough power to receive and display RF echoes from distant targets.

The Doppler radar is used for navigation and for proximity fusing in SAMs and AAMs. CW radar can help to provide reliable information on aircraft position by integrating velocity and time flown. In other words, if the Doppler radar indicates a groundspeed of 360 knots and time in flight from a known position is 10 minutes, the present position of the aircraft is 60 miles downtrack from the last known location. A proximity fuse is used to detonate a missile when the weapon is as near as it ever will be to the target. The fuse transmits a CW signal and receives the echo from the target. As long as the echo frequency is higher than the transmitted frequency, the missile is approaching the target and the fuse will not detonate. The instant the distance between the missile and the target begins to increase, the missile will be as close as it ever will get to the target. At this instant, the echo frequency will become less than the transmitter frequency, and when the receiver senses this, the fuse is detonated.

Though uses do exist for the CW radar, the system is limited. For Doppler radar to increase

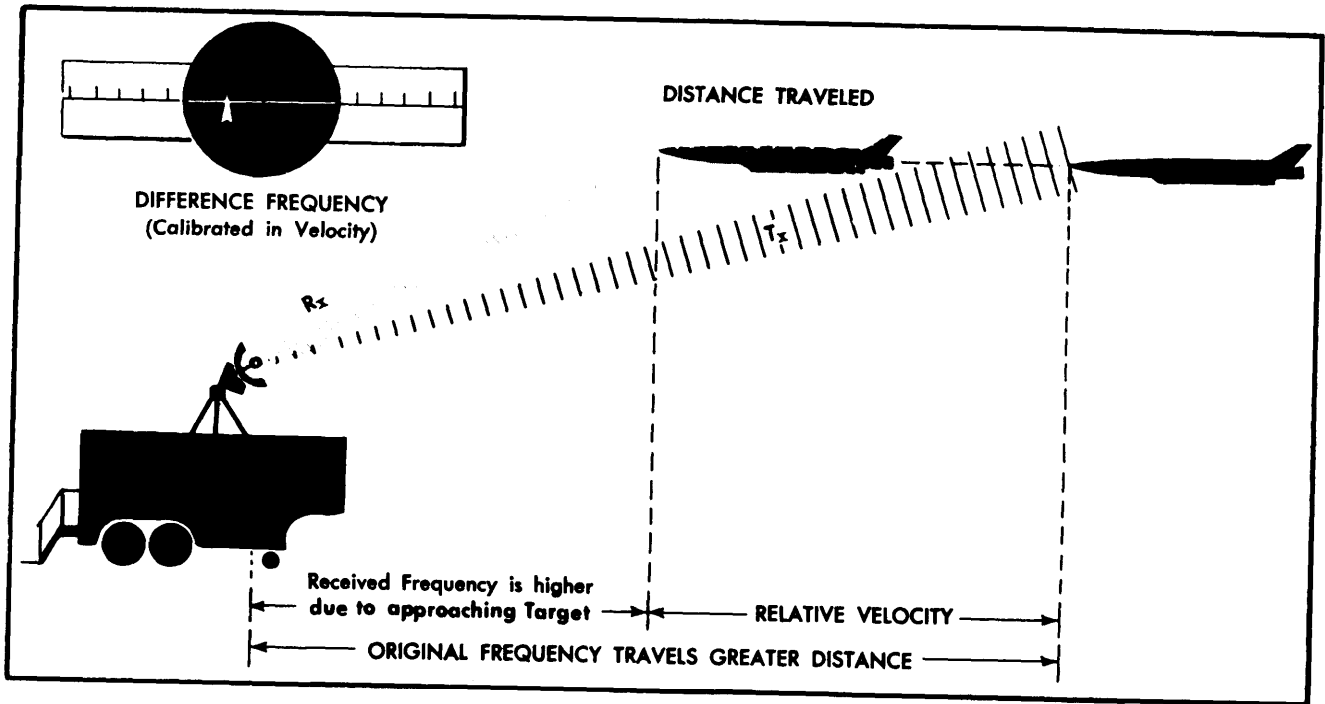

Figure 2-30. Doppler Radar.

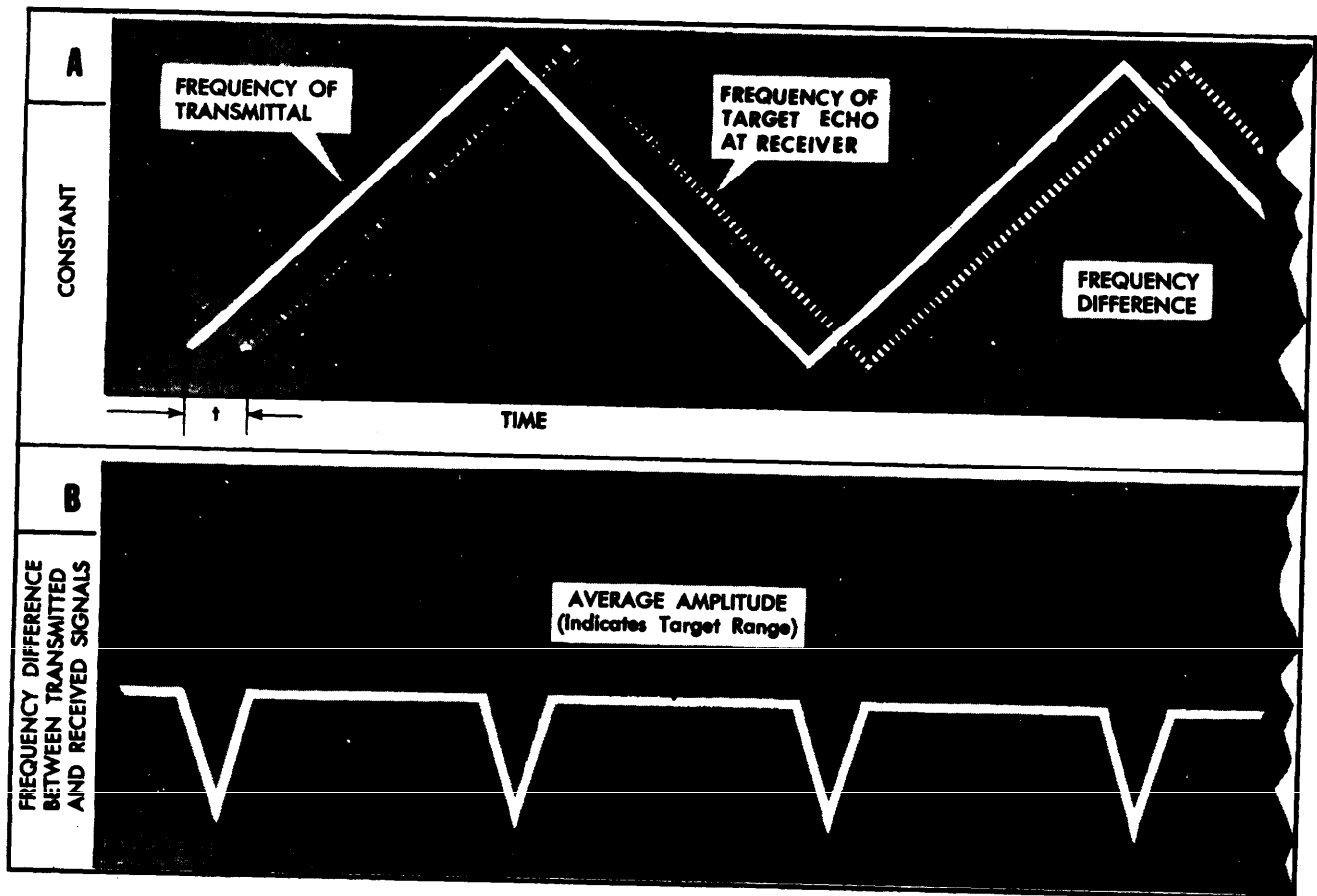

Figure 2-31. Stationary Target.

in its application, it is necessary for it to provide more than velocity information alone (figure 2-31, stationary target no velocity).

FM-CW Doppler

By modulating the frequency of the CW Doppler radar, it is possible to measure range as well as relative velocity. With FM ranging, the interval between radar transmission and reception is converted to a frequency difference. From this, range can be determined by comparing frequencies. This is accomplished by transmitting a wave that constantly increases and decreases in frequency. Instantaneous comparisons are then made between the RF being transmitted and the RF of the echoes. Since the radar "knows" when it transmitted on a particular frequency and can compare it to the received echo, the result is a time which yields range (figure 2-32).

The principal application of FM-CW Doppler has been to radar altimeters. Absolute aircraft altitude can be measured by pointing a radar antenna downward and then finding the range to the ground by comparing the difference in frequency. Because the distance from the aircraft

to the ground is generally just a few miles, the CW system is ideal for altimeters. Echoes are usually quite strong despite the low power characteristic of the CW transmitter. However, due to the need for more powerful radars, a new type of Doppler system was devised which derives its high power from its pulsed operation. This system is called pulsed Doppler.

Pulsed Doppler

A pulsed Doppler system approaches the basic principles of a simple CW system except that it employs PM in order to achieve higher peak power, greater range, and less susceptibility to unfriendly detection. Basically, a pulse is formed by rapidly turning a transmitter on and off. The result is a powerful burst of EM energy which is capable of providing range and velocity information. Because the rate at which pulses are generated varies from radar to radar, it is difficult for the enemy to degrade the pulsed Doppler system. In order to grasp the significance of pulsed Doppler radar, it is necessary to understand the harmonic composition of the pulse and how pulse duration affects range and resolution.

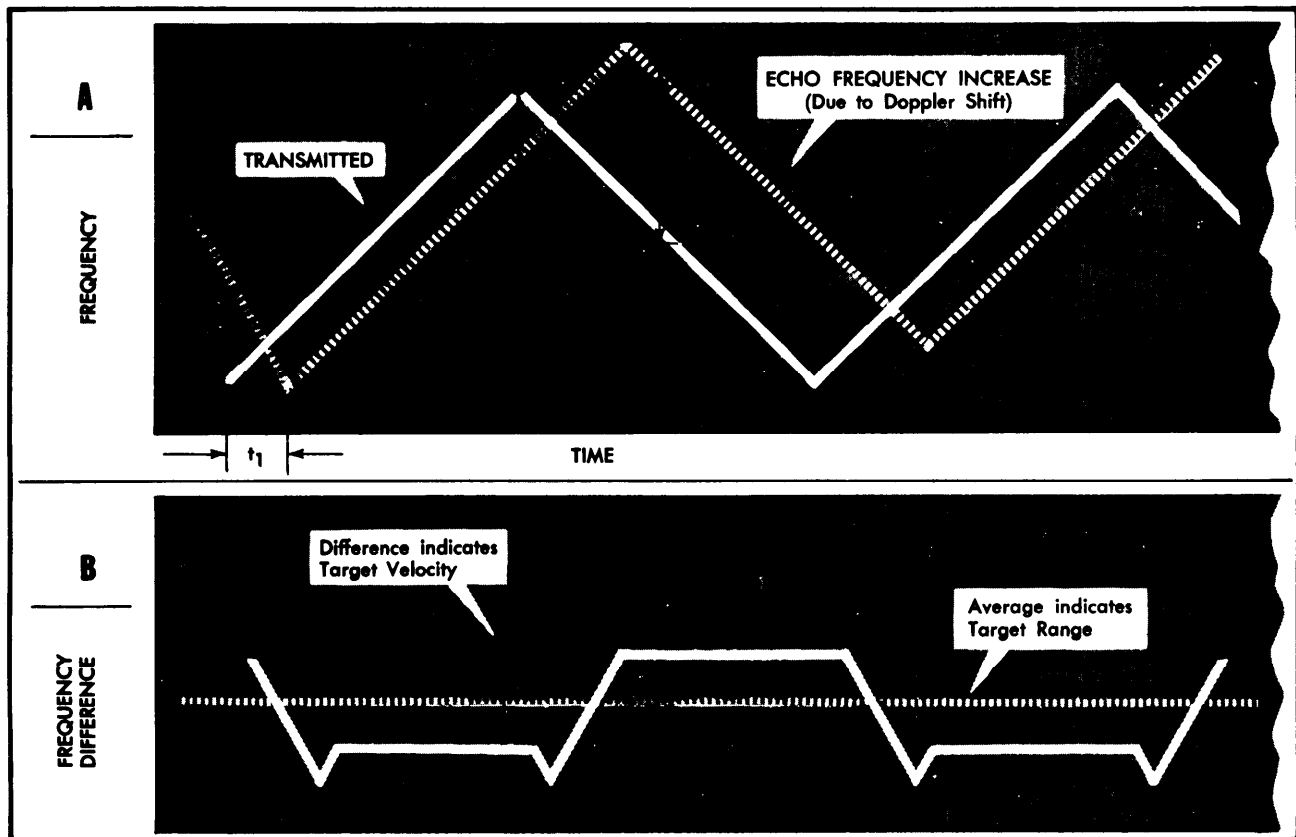

Figure 2-32. Target Moving Toward Radar.

The shape and size of a pulse are formed by harmonics. A harmonic is an integer of a fundamental frequency. For example, the harmonics of 60 Hz are 120 Hz, 180 Hz, etc. The number of harmonics in the pulse is determined by the duration of the pulse, or in other words, by the length of time the transmitter is turned on. When the pulse reflects off a target, the harmonics within shift in frequency. This is then measured and compared by the radar and converted to a target velocity.

The shape of the pulses and the rate at which they are generated (PRF) contribute to radar capabilities. For example, a narrow pulse provides good resolution (see basic radar principles), but a long, wide pulse has more power, thus enabling it to be received off of targets at greater ranges. Actually, a radar's PRF has more effect on range capability. If the rate of pulse generation is low (a long distance between pulses), then the transmitter has time to compare pulses which have traveled a great distance. Conversely, a transmitter with a high PRF (a short distance between pulses) is not as capable of detecting targets at long range because it has less time to "look" at the pulses it has radiated (figure 2-33).

Since a radar cannot tell which echoes belong to which pulse, there is the possibility that the measured range to a target will be uncertain. This problem does not exist provided all the echoes of a single pulse are received prior to the radiation of the next pulse. But if the radar transmits again

before all of the echoes return, the result will be a range ambiguity that displays the target as being closer than it really is. Range ambiguities can be eliminated by restricting the display of returns beyond a radar's maximum ambiguity range. This range can be determined mathematically:

$$R_u = \frac{cT}{2}$$

R_u = Max unambiguous range

C = Speed of light

T = PRI

Radars which display targets beyond this range will register ambiguities. Another ambiguity problem with pulsed Doppler has to do with blind speeds. This occurs when a target echo returns with a Doppler shift equal to the PRF of the radar, negating the display of that target.

To understand this and see how pulsed Doppler operates, the harmonic composition of a rectangular waveform must be examined.

Figure 2-34 shows the harmonic composition of any rectangular (pulsed) waveform. It can be mathematically proven that any waveform other than a sine wave is composed of many different pure sine waves added together in the proper amplitude and phase relationships. In the case of a radar's pulsed waveform, this composition consists of a fundamental frequency (the radar's PRF) and the sum of all the harmonics in the proper amplitude and phase (figure 2-35). Note the three loops of frequencies on either side of the carrier. These are nothing more than the carrier plus all the frequencies in the rectangular waveshape and the carrier minus all those same frequencies. The important thing is that there are many frequencies present. Doppler principles would tend to indicate that if this pulse-modulated waveform were transmitted and relative motion existed between the transmitter and a reflecting surface, a frequency shift would occur, and indeed it does. Every single frequency present (each frequency is known as a single spectral line) experiences a spectral line frequency shift. If the frequency of a transmitted harmonic could be compared to the frequency of the Doppler-shifted returning frequency, basic Doppler velocity information could be determined. This can be done by comparing the frequency of the carrier to the frequency of the returning shifted carrier; and by noting the difference, velocity can be computed as in a simple CW Doppler system. This extends range, and since all information can be

CATEGORIES OF PRF

PRF	RANGE	DOPPLER
HIGH	Ambiguous	Unambiguous
MED	Ambiguous	Ambiguous
LOW	Unambiguous	Ambiguous

Figure 2-33. Range and Doppler vs PRF.

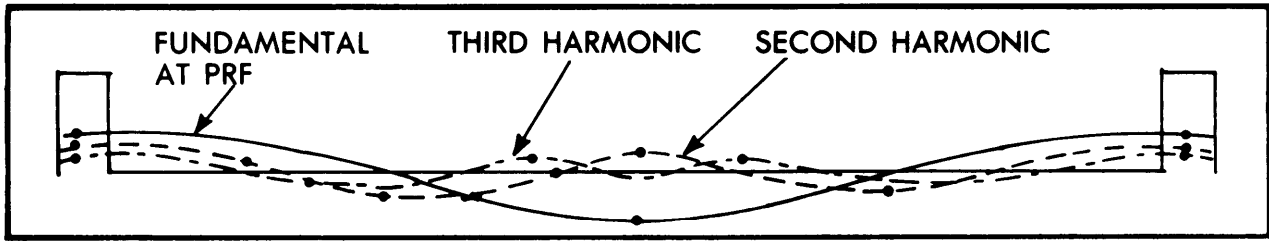

Figure 2-34. Harmonic Content of a Rectangular Waveform.

gathered on the basis of one pulse, the system is difficult to detect and counter. This property will make pulse Doppler an important device in EW in the years to come.

SUMMARY

EM radiation is based on two basic principles. First, radiation is the propagation of a wave of energy through free space at the speed of light, 186,000 statute miles per second. Second, information can be transmitted and received on this wave of energy. Various methods are used to modulate radar waves, including amplitude, frequency, and PM.

The above modulation methods form a basis for all radar equations:

$$\text{maximum theoretical range} = \frac{\text{PRI } (\mu\text{sec})}{12.4(\mu\text{sec}/\text{NM})}$$

$$\text{and power density} = \frac{P_t \text{ WATT}}{4 r^2 \text{ cm}^2}$$

A simple pulsed radar whose components are common to all radar systems consists of a DC power supply, timer, modulator, RF, generator/oscillator, antenna, receiver, and an indicator. Radar systems are designed to give only range, azimuth, elevation, or a combination of these three pieces of information. Radars are further classified by uses. Three classes are indirect threat, threat, and nondirect threat radars. Each class may have different scan or search patterns. Some patterns are circular, conical, raster, and spiral or combinations of the patterns.

Indirect threat radars usually have a long-range, high-power capability. Their primary use is early detection of incoming aircraft. Accuracy has secondary emphasis. Early warning, some acquisition, and HFRs are included in this class.

Direct threat radars supply information directly to a weapon system capable of destroying an aircraft. Conical scanning AAA, raster or conical scanning AIs, along with TWS missile systems belong to this group. Nonthreat radars consist of, but are not limited to, airborne navigation, space, or airport surveillance and Doppler radars.

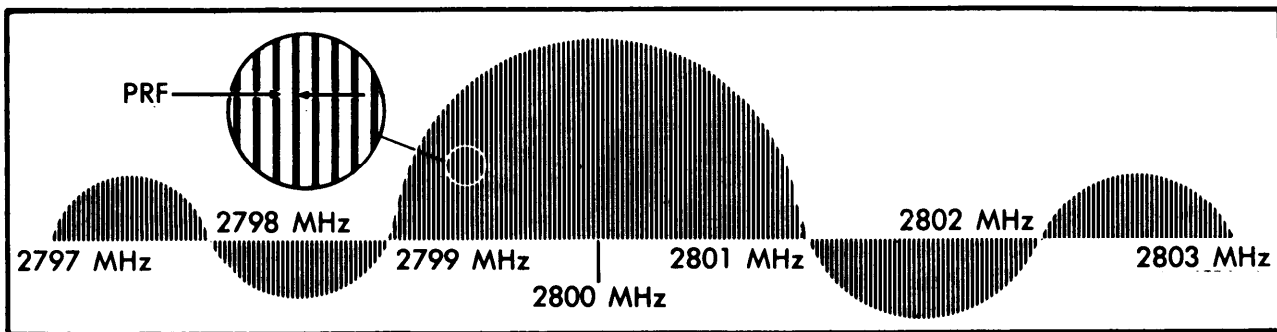

Figure 2-35. Pulse Modulated RF Waveform.

Chapter 3

COMMAND, CONTROL, AND COMMUNICATIONS (C³) AND C³ COUNTERMEASURES (C³CM)

Command and Control - The exercise of authority and direction by a properly designated commander over assigned forces.

JCS Pub 1

C³

Effective control and direction of forces in battle is often the deciding factor in victory. Commanders from platoons or flight leaders to the Commander in Chief must know the disposition and status of their units. Effective military action cannot be taken without also knowing the enemy's strength, capabilities, and position. An elaborate system of sensors, communications, support and execution elements, and command centers exists to inform commanders, transmit commanders' orders, and provide feedback.

At the apex of the US Strategic Command and Control System, is the Worldwide Military Command and Control System (WWMCCS). WWMCCS supports the National Command Authorities (NCA) (NCA—the President, Secretary of Defense, or their alternates) at the hub of the network. The National Military Command Center (NMCC) at the Pentagon, the alternate NMCC (ANMCC) in a Maryland mountain, and the E-4B National Emergency Airborne Command Post (NEACP) provide the command center facilities for our national leaders. A special feature of WWMCCS is the Minimum Essential Emergency Communications Network (MEECN) which links the NCA with our Single Integrated Operations Plan (SIOP) strategic nuclear forces (figure 3-1).

The NCA is in contact with all fixed military and civilian agencies through the Defense Communication System (DCS). In the US, these communications occur through commercial channels; overseas, the system is mostly government owned and operated by the Defense Communications Agency.

C³CM

C³CM is the integrated use of OPSEC, military

deception, jamming, and physical destruction, supported by intelligence, to deny information to, influence, degrade, or destroy adversary C³ capabilities and protect friendly C³ against such actions (DOD Directive 4600.4). C³CM includes both offensive and defensive applications—to deny an adversary effective use of C³ systems, while preserving friendly capability to employ our C³ systems.

On the battlefield, C³CM adds to our combat power, while degrading the enemy's effectiveness. The concept of C³CM transcends strategic and tactical boundaries and must be a coordinated effort between theaters and among joint forces within a theater. In theaters, commanders apply combined C³CM assets (both disruptive and destructive) of air, ground, and naval forces to maximize their military power.

OPSEC. The process of denying adversaries information about friendly capabilities and intentions by identifying, controlling, and protecting indicators associated with the planning and conduct of military operations and other activities (JCS Pub 18).

Military Deception. These are actions taken to mislead foreign decision makers, causing them to derive and accept appreciations of military capabilities, intentions, operations or other activities that evoke foreign actions that contribute to the originator's objectives (JCS Pub 1, DOD Directive 4600.4). There are three categories of military deception: strategic, tactical, and service/departmental military deception.

Jamming. Electronic jamming is the deliberate radiation, reradiation, or reflection of EM energy with the object of disrupting the use of electronic devices, equipment, or systems being used by an enemy. Electronic deception is the deliberate radiation, reradiation, alteration, absorption, enhancement, or reflection of EM energy in a manner intended to mislead an enemy in the interpretation or use of information received by the enemy's electronic systems. Manipulative electronic deception (MED) is the alteration of friendly EM emission characteristics, patterns, or procedures to eliminate revealing, or convey

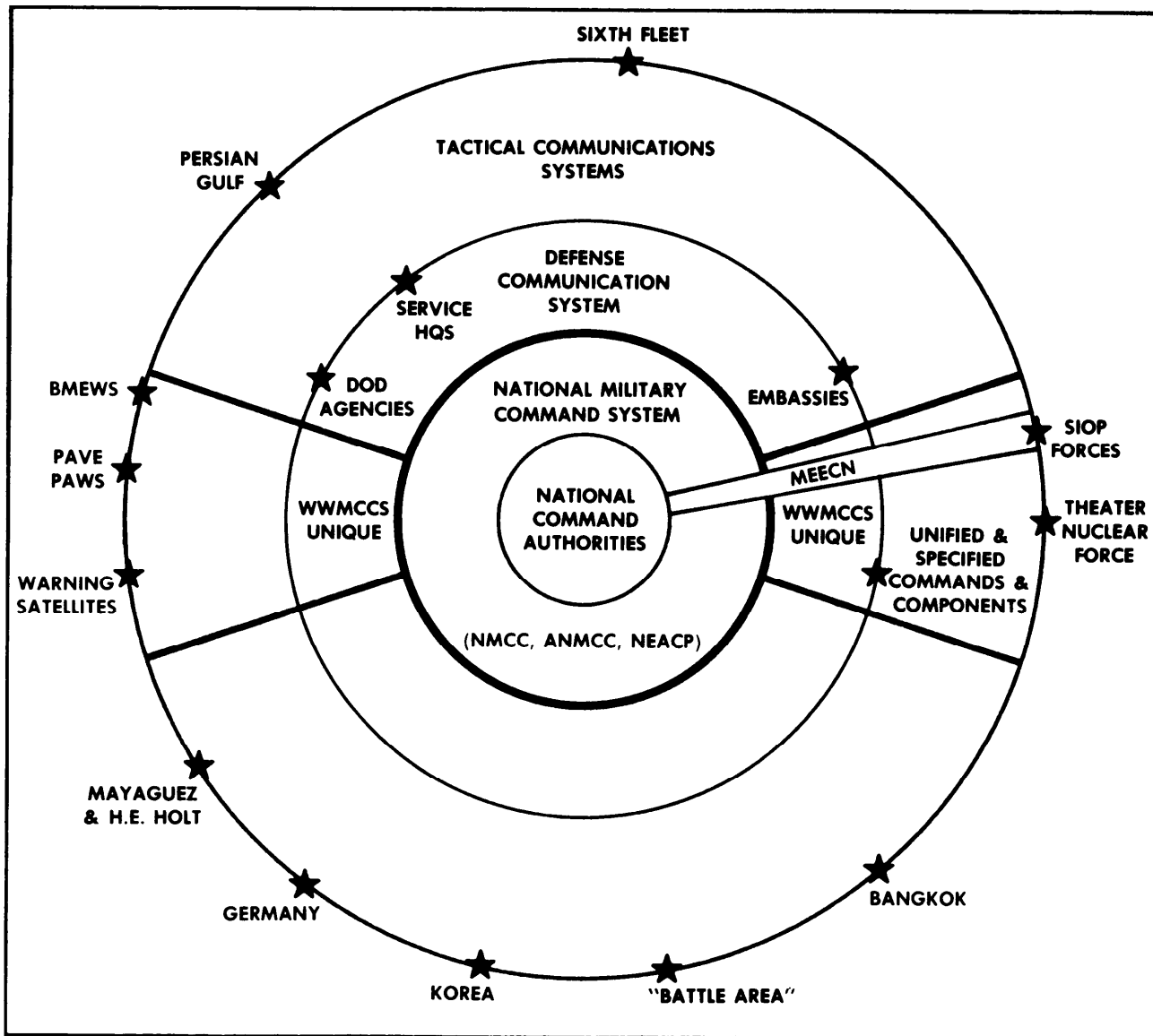

Figure 3-1. Worldwide Military Command and Control Network.

misleading, telltale indicators that may be used by hostile forces. Simulative electronic deception (SED) is the creation of EM emissions to represent friendly notional or actual capabilities to mislead hostile forces. Imitative electronic deception (IED) is the introduction of radiations into enemy systems which imitate enemy emissions (JCS Pub 1, DD List #130).

Physical Destruction. Physical destruction is the use of lethal resources, such as firepower, to destroy enemy resources. Destruction is accomplished through the use of specific weapons and techniques, ranging from classical bombing, with conventional munitions, to intense radiation and

high energy particle beam overloading.

The more the enemy depends on centralized control for force employment and execution, the more susceptible that enemy should be to C^3CM . EC operations can make it very difficult for enemy commanders to receive or transmit the data necessary to monitor, adhere to, or to adjust their plans.

The C^3CM components listed above are not new. OPSEC, military deception, and physical destruction predates the Trojan Horse. Jamming was used before WW I. While the use of these military activities has been documented throughout history, the idea to use them in an integrated fashion to adversely affect enemy C^3 is new.

Chapter 4

ELECTRONIC WARFARE (EW)

A second subarea of EC is EW, which can take place in either the communications, radar, or optical frequency ranges. There are three divisions of EW: ESM, ECM, and ECCM. A definition of each division follows with the remainder of the chapter discussing each division in depth.

1. **ESM.** ESM is that part of EW involving actions taken under direct control of an operational commander to search for, intercept, and identify and locate sources of radiated EM energy for the purpose of immediate threat recognition. Thus, ESM provides a source of information required for immediate decisions involving ECM, ECCM, threat avoidance, targeting, and other tactical employment of forces.

2. **ECM.** ECM is that part of EW involving action taken to prevent or reduce an enemy's effective use of the EM spectrum, primarily through jamming and deception. ECM is not limited to, but includes electronic jamming and electronic deception (previously defined in chapter 3).

3. **ECCM.** That part of EW involving actions taken to retain effective friendly use of the EM spectrum. ECCM may take the form of hardware "fixes" to equipment such as automatic gain control (AGC) on radars, or antijam features on UHF or VHF radios; or it may be in the form of training and recognition of the effects of the enemy's ability to perform ECM against you. Both aspects of ECCM—hardware orientation—and training/awareness orientation are equally important.

ELECTRONIC SUPPORT MEASURES (ESM)

ESM provides information in a timely fashion and in forms that are readily usable by the activities which it supports. The prime consumers of ESM information are the operations personnel engaged in other EW activities; that is, ECM and ECCM.

The importance of ESM as a segment of EW and as a segment of the total spectrum of conflict lies in the fact that it acts as the "eyes and ears" of the commander who engages in, or is engaged by, EW operations. ESM provides information essential to the success of operations in the air combat environment.

The treatment of ESM exclusively as an immediate response, tactically oriented, concept is relatively new. Previously, ESM was more broadly defined to encompass EM radiation collection efforts for subsequent intelligence exploitation and support of military operations, as well as immediate support in the combat environment. These collection efforts (which focus on longer term intelligence objectives, although they may also support operations in progress) are now generally included in the area of SIGINT.

The relationship between SIGINT and ESM can be made less confusing, perhaps, by considering some specific aspects of that relationship. SIGINT and ESM may, and generally do, use the same equipment technology. SIGINT provides intelligence data for a range of consumers and a variety of purposes including planning, research and development, and operations, among others. While SIGINT may provide indirect or direct support to the tactical commander, ESM directly supports the tactical commander. ESM provides the tactical commander with a capability which can be totally integrated with other force capabilities. ESM assets are totally controlled by the theater commander while SIGINT assets are responsive to national level tasking requirements.

This chapter will focus briefly on the functions of ESM and the generics of ESM systems, discuss related aspects of SIGINT efforts and the systems employed, and close the loop with a discussion of intelligence support to EW.

Functions of ESM

ESM applies in a wide range of activities, such as threat location, detection, warning, emitter (or threat) avoidance, target acquisition, homing, and destruction or suppression. ESM encompasses the expansion of operations throughout the EM spectrum.

One function of ESM is to locate the enemy through EM search and intercept of emissions radiated intentionally or unintentionally from the enemy's equipment. Any of several purposes may be served by this kind of ESM activity. The information could, for example, be obtained by the aircraft radar warning receiver (RWR) and used by the crew as warning of possible hostile attack or as the basis for avoiding radar coverage.

In another case, ESM aircraft could provide direct warning or control assistance to other engaged friendly forces. An emitter attack, or suppression system might use the intercept and locating functions for acquiring targets for homing and attacking emitters of various types.

Radar Warning Receivers (RWR)

Radar surveillance and radar-directed weapons represent major obstacles to aircraft survival. The first step in countering this is to provide the aircrew with a rapid and accurate assessment of the signal/threat environment in which they are operating. A radar warning system or "warning receiver" must accomplish this by comprehensively surveying the threat spectrum, sorting through a multitude of incoming pulses, and determining which represent threat-type signals and which of these are specifically endangering the aircraft. Because of the complexities of deriving accurate warning data in modern, dense signal environments, a well-trained operator is necessary to correctly interpret the many responses of a given warning device.

The requirements for an ideal RWR are: (1) high probability of intercept, (2) adequate sensitivity, (3) selectivity, (4) high quality signal processing or "fidelity," (5) minimum size, and (6) maximum reliability.

First, and possibly foremost, a warning receiver must have a high "probability of intercept." That is, it must comprehensively survey the entire threat spectrum and have a high probability of being tuned to the correct radar frequency in order to initially capture it. For best probability-of-intercept, we need either a system with a wide frequency bandwidth or a rapidly tuned narrow-band system. Another requirement is correct system sensitivity. Each incoming radar pulse is extremely weak, so one principal function of the receiver is to amplify the signal for processing. Care must be taken to ensure that only valid radar signals are amplified rather than background noise. Otherwise, the amplified noise merely triggers random false alarms. Additionally, the warning receiver should respond only when a radar signal represents an immediate threat to the aircraft. This means the system should only respond when the main beam of a radar is pointed directly at the aircraft. If the receiver is so sensitive that it triggers on weak signals, radar side lobes, or noise, a multitude of false warnings result. The bottom line is the warning receiver must have adequate sensitivity to detect immediate threats but not give false alarms for noise or side lobes.

The ideal warning receiver must also have selectivity and fidelity. In a dense signal environment, the receiver must sort through a large number of incoming radar pulses and correctly identify and process only those pulses which represent potential threats. This requirement is referred to as "selectivity." The ability of the receiver to exploit modern radar features with high quality processing techniques is referred to as "fidelity." Finally, the warning system should be as small and light as possible due to space limitations on many newer aircraft.

ESM Systems

At the heart of an ESM system is a receiving capability in the frequency band of interest plus auxiliary equipment as required to perform the assigned mission (location and analysis, warning, or suppression) (figure 4-1). The basic ESM sensor is a receiver, comparable in principle to a home radio receiver, and operating in the frequency band dictated by mission requirements. Within its frequency range, the receiver may simultaneously receive all signals (a "wide-open" capability) or have the capability to be manually or automatically tuned throughout its band to intercept and isolate signals within a narrow portion of the total band.

Once a signal of interest has been intercepted, the receiver provides an output in a form compatible with the particular mission being accomplished. For example, ESM systems may employ logic circuitry which automatically compares received signal characteristics to known parameters of specific radar systems and identify intercepted signals which are of interest. IR signals are identified by both radiation frequency and intensity. Other signals are identified by their own peculiar "fingerprints" or parameters including modulation type and content, relative power, frequency, pulse recurrence frequency, PW, scan type, and scan duration.

Location information may be presented to the aircrew member as a relative quadrant in which the signal is located, as the precise relative azimuth (or bearing) of the signal, or in the form of site location (range and bearing or coordinates) depending on the sophistication of the location device and the mission of the aircraft in which it is installed.

Operationally deployed ESM systems range from RWRs of several types installed on most firstline aircraft to precision emitter location equipment installed on some direct attack and tactical support aircraft. Similar, but generally

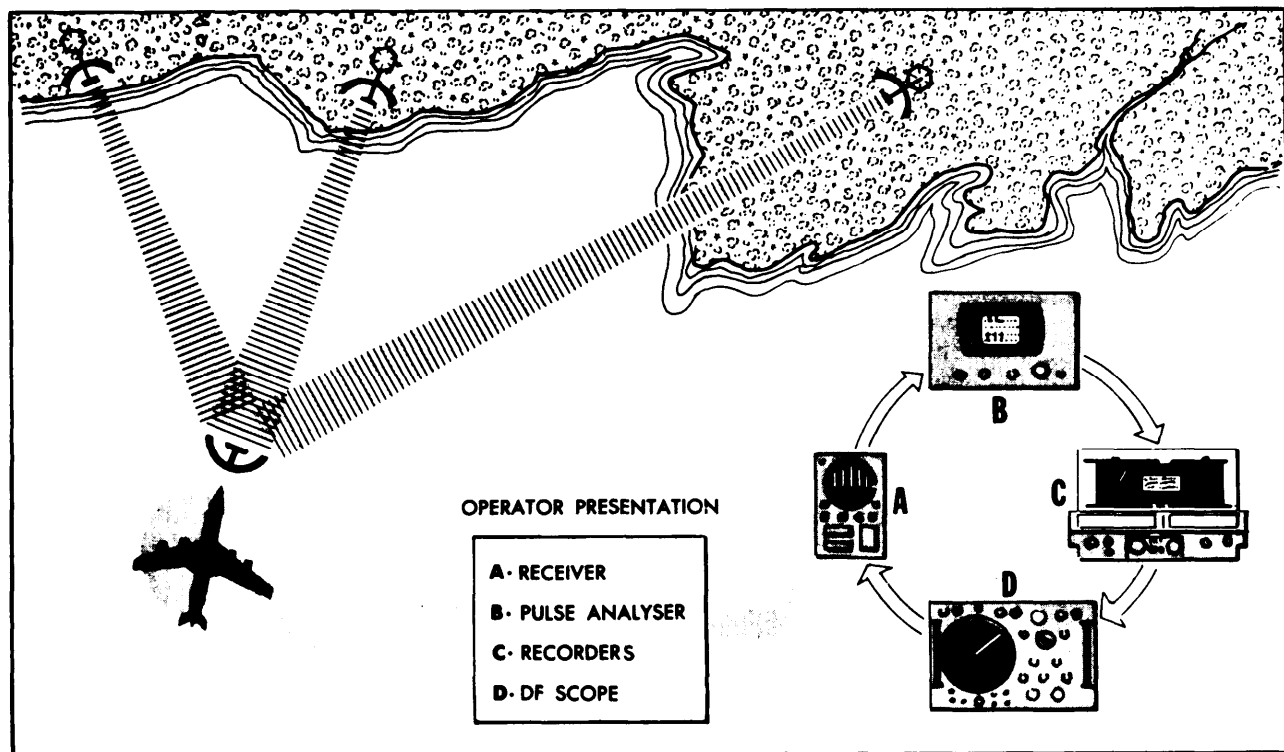

Figure 4-1. ESM Sensor.

more sophisticated, systems are employed in SIGINT collection.

ELECTRONIC INTELLIGENCE (ELINT)

ELINT is the major subdivision of SIGINT which collects and processes data on noncommunications signals, such as radar. ELINT's primary purpose is intelligence gathering during both wartime and peacetime.

Basic Systems. The basic ELINT sensor is a receiver in the frequency bands of interest. The usual auxiliary functions are analyzing, recording, and locating the source of the intercepted signal. The receiving and auxiliary functions may be performed manually or with automatic equipment. Manual radar signal analysis is usually done by using a pulse analyzer which enables the operator to view the individual pulses of energy transmitted by a radar in order to measure its PW, PRF, and antenna scan type and scan rate. Signal parameters may be recorded from the receiver with an audio or video tape recorder or by photographing the display of a signal analysis system. These recordings are used for detailed post-mission analysis. DF equipment is used to

determine the locations of intercepted emitters. In a manual ELINT sensor system, virtually all components of the system are controlled by the operator.

Automatic Systems. An automatic or semiautomatic sensor system is normally computer controlled. With this type system, an operator may monitor and modify its operation during the various phases of an ELINT mission. The automatic or semiautomatic sensor is capable of in-flight intercepting, sorting, identifying, locating, and processing large quantities of signal data. Such a system is often used to direct manual systems for indepth collection against high interest emitters. Automatic and semiautomatic sensors employ a computer to tune the receiver through its frequency range independently of an operator or to alert the operator when signals of high interest are intercepted.

Automatic systems can search, intercept, sort, and measure the parameters of all signals within the frequency range of the receiver and determine the direction of each signal relative to the aircraft. With this data and precise navigation information, the computerized system can determine the location of each signal when three or more bearings have been measured. These coordinates,

which represent site location, and the signal parameters form a digital notation which completely describes each intercept.

Automatic systems using large capacity computers can be loaded with data files containing location information and radar parametric data. With these files or data bases, it can compare each intercept to determine if it is a known radar type and if it is emanating from a known site. Through this process, it can rapidly identify and categorize each intercept. The airborne operator may select any category and direct other collection equipment to exploit these signals. The operator can also use this data to provide real-time warning to other friendly aircraft.

All raw intercept and navigation data and the results obtained during the data base correlation can be recorded. Digital format recordings made from automatic sensors are used during the ground processing and reporting cycle.

SIGINT/ESM OPERATIONS

Peacetime SIGINT/ESM missions, which must respect national boundaries and airspace, fly border or peripheral routes (figure 4-2).

Wartime SIGINT/ESM missions or exercises of friendly forces may penetrate hostile or simulated

hostile airspace to collect necessary data for attack or EW support operations or to provide warning to other engaged friendly forces. Planning for a penetration mission should be directed toward providing a route and techniques that will enable the aircraft to accomplish its objectives with minimum risk (figure 4-3).

Another mission planning factor is the operating schedule of a particular emitter of interest. In wartime, this has minor significance since a country may use its entire air defense system when enemy forces are in the area. In peacetime, however, a nation usually maintains fewer emitters in operation at any given time because of security and economic considerations.

Because modern SAM and AAA systems are extremely mobile, the timeliness of the information collected by the SIGINT/ESM aircraft is very important. In a fluid battle situation, the force commander must be informed of the changing electronic order of battle (EOB) as quickly as it is known since tactical decisions are based, in part, on the enemy's EOB.

SIGINT mission reconstruction using navigation, signal location, and parametric data provides intelligence data for exploitation and planning factors for future SIGINT operations. Bearings from individual radars should all intersect near to or be resolved at one point—the radar site

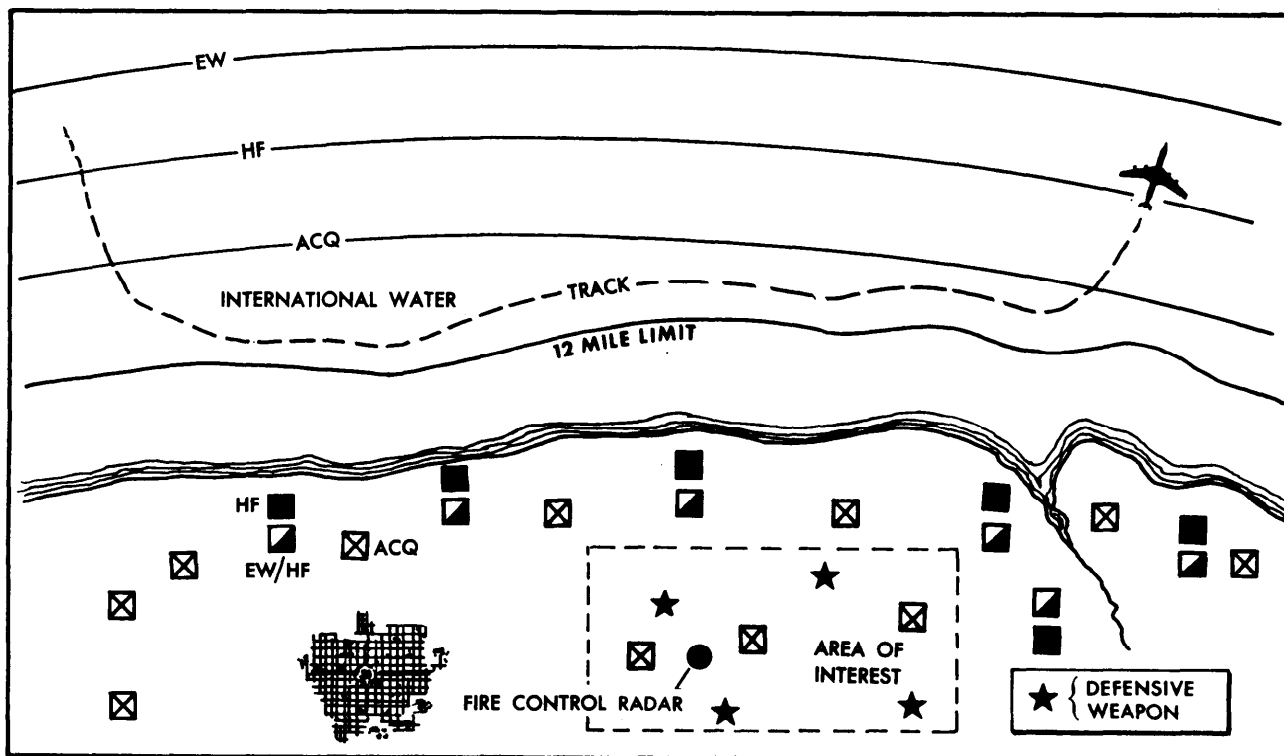

Figure 4-2. Peripheral Reconnaissance Route.

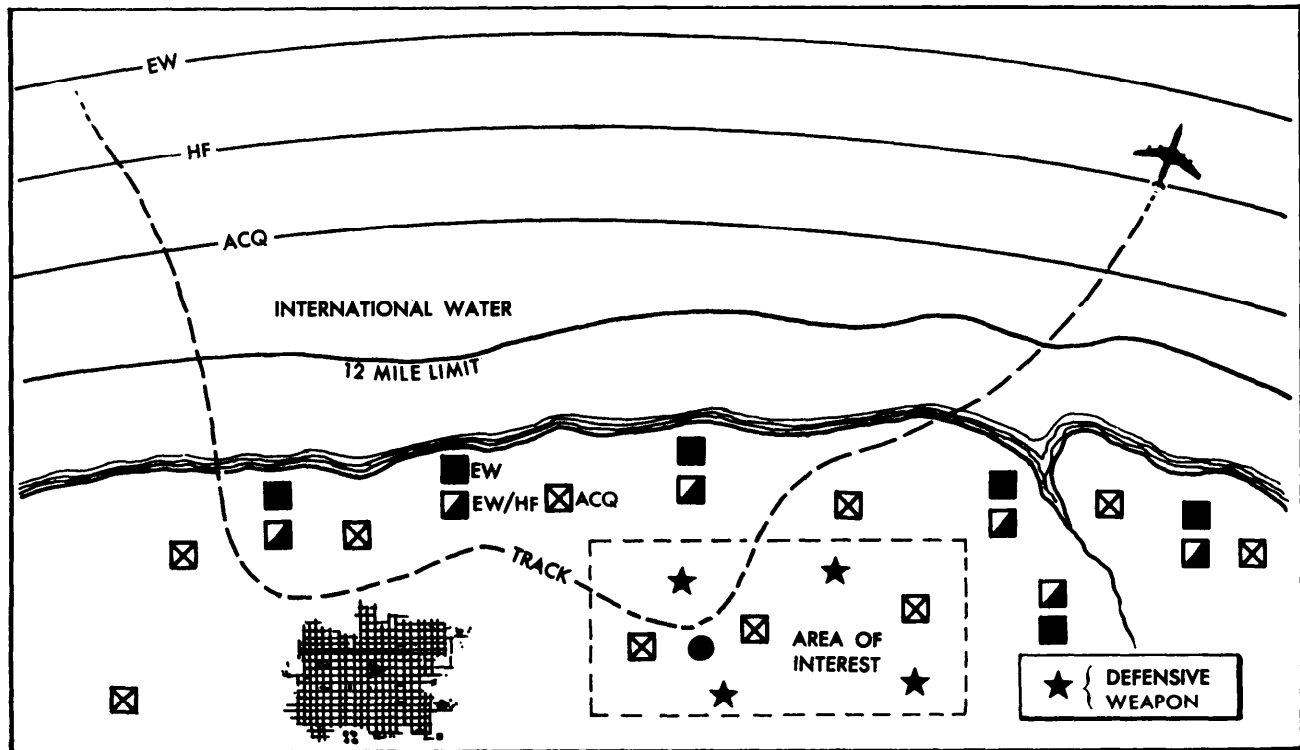

Figure 4-3. Penetration Reconnaissance Route.

(figure 4-4). The accuracy of the site location depends on operator proficiency, signal characteristics, accuracy of navigation data, and capability of the DF equipment. Signal parameter information is used to identify each signal. As explained in chapter 2, each general type of radar (early warning, height finder, and fire control) is designed with certain parameters which enable it to perform its particular function. By comparing the intercepted parameters against these typical characteristics, the general type of radar can be determined. Further comparison with the parameters of known radar systems can result in identification of the signal as a specific radar system or designation of the emitter as a new or modified radar (figure 4-5).

Known radar parameters are contained in an ELINT parameter listing or in digital data bases called "type files." Information on the locations and types of radars is provided to operational users and to intelligence activities where it may be used as input for the EOB. This EOB, incorporating all available data, is made available to planners and crewmembers to enable them to better plan and conduct operations in the area surveyed.

Implicit in the above discussion is a cycle of operations commonly called the SIGINT collec-

tion cycle. In general, this consists of tasking by proper authority based upon a need for information, planning the use of resources to accomplish the task, performance of the mission itself, and finally, analysis, processing, reporting, and evaluating the mission results. The information obtained is applied against the original tasking, and new or supplementary tasks are developed, thereby beginning the cycle again.

IMPROVED SYSTEMS

In the classical SIGINT mission, an aircraft flies the collection mission, returns, and the collected data is processed, evaluated, and disseminated. The dynamic nature of the combat environment requires reduction of the time involved in SIGINT reporting and making usable ESM data immediately available.

Several systems, operating in near real time, have been proposed to increase the efficiency of SIGINT collection efforts. One such system would relay the collected information back to a ground site for evaluation and immediate implementation into current plans and operations.

Another proposed system would employ precision location systems to determine the location of

threat emitters. In a continuing ESM role, these same aircraft could direct attack aircraft to the emitters and support them during their operations.

It would be incorrect to imply that SIGINT/ESM roles can be performed only by aircraft. Various other collectors, including shipborne and ground-based units, are used extensively throughout the totality of the SIGINT/ESM effort. Remotely piloted vehicles (RPV) also have a wide range of applications in this area.

The RPV offers several cost and operating advantages. An RPV may be sent into a high threat area to perform the same mission that might expose an aircraft and crew to an unacceptable risk. The ideal RPV would be a multimission vehicle; that is, the same basic RPV would be capable of being reconfigured in a timely manner to perform any one of several mission types.

SIGINT mission data may be stored on board the RPV for processing after recovery. However, if the collected information can be relayed back to a ground site via a telemetry type system, response time can be reduced considerably and ESM applications are feasible.

The alternatives and applications offered by the use of RPVs and other ESM platforms are wide

in scope. Accordingly, any discussion of EW or any of its divisions must not be limited solely to manned aircraft.

INTELLIGENCE SUPPORT TO EW

Achievement and maintenance of EW superiority require continuous and timely updating, improvement, or replacement of EW systems, tactics, and techniques. These actions, in turn, depend upon factual and detailed knowledge of the capabilities and intent of a possible enemy, encompassing the enemy's technology, systems and tactics, and the strategic and doctrinal considerations underlying their use. Current and complete intelligence on enemy EM capabilities and usage is a fundamental necessity for effective and successful EW programs.

This requirement for knowledge extends across all facets of EW. At the employment end of the spectrum, such knowledge determines the success of operations; while at the other end, scientific and technical intelligence is absolutely essential for activities involving R&D, equipment design, and procurement to provide optimum EW capabilities.

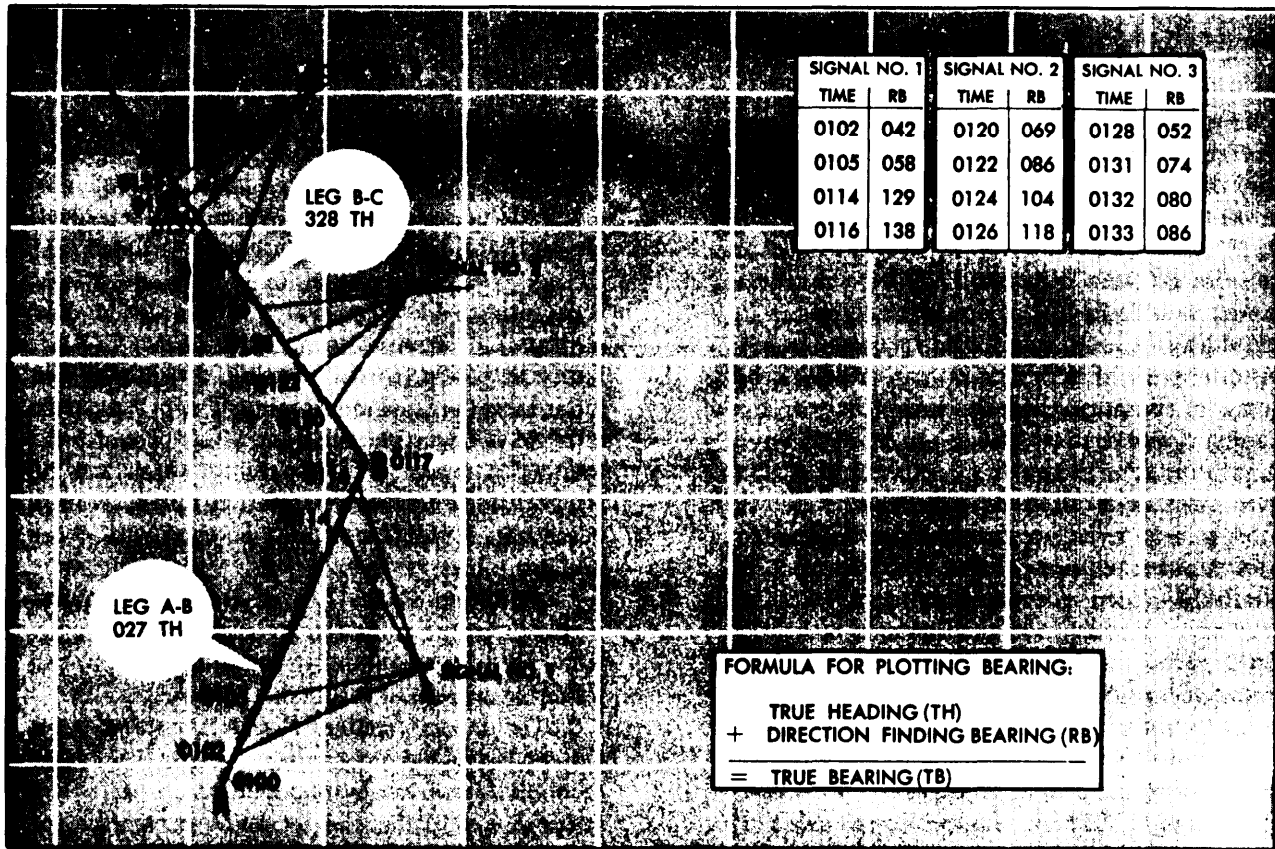

Figure 4-4. Locating Site of Intercepted Radar.

TYPE	FREQUENCY	PULSE WIDTH	PRF	POLARIZATION	SCAN DURATION
EW	50-100, 700-1,000 2,000 - 2,400	3.0 - 10.0	70 - 360	H	8.0 - 30.0 SEC
HF	2,000 - 2,650	1.5 - 3.5	70 - 360	H	1.9 - 3.0 SEC
ASR	2,600 - 2,750	0.5 - 1.5	700 - 1,500	V	3.0 - 6.0
FC	2,700 - 3,000 5,000 - 6,000	0.5 - 1.5	700 - 2,000	H/V	CONICAL SCAN 14 - 40 CYCLES PER SEC.

MODEL NO.	FREQUENCY	PULSE WIDTH	PRF	POLARIZATION	SCAN DURATION
FC-1	2,650 - 2,710	0.5	2,000	V	30 CPS CONICAL
FC-2	2,711 - 2,820	0.9	1,800	H/V	30 CPS
FC-3	2,830 - 2,850	1.2	1,200	H	15 CPS

SIG	FREQUENCY	PULSE WIDTH	PRF	S.D.	POLARIZATION	REMARKS
1	2,800	0.9	1,800	25 CPS	H/V	CONICAL SCAN

Figure 4-5. Identifying Type of Intercepted Radar.

Intelligence used to support EW activities and operations comes from a multitude of sources, including human (HUMINT), photo (PHOTINT), electronic (ELINT), communications (COMINT), and others. Of these, the signals intelligence sources of COMINT and ELINT have much in common with ESM and are particularly useful in providing the kinds of information required in EW applications. ESM activities may, themselves, be sources of intelligence information when, for example, the data produced on an ESM mission is responsive to a known intelligence need. Other EW sources of such data are ECM missions, emitter attack, strike, reconnaissance, and other sorties when equipped with RWRs, as well as similarly equipped ground-based elements. The task of detailed evaluation and fusion of SIGINT/ESM data with other intelligence information is a part of the production process used in providing support to EW and other operational functions.

The point to be made is that there is no clear-cut line between the divisions of EW. ESM, ECM, and ECCM are all closely interrelated. This relationship will be shown as the subject of EM domination is pursued.

SUMMARY OF ESM

EW support measures is that part of EW involving actions taken to search for, intercept, identify, and (or) locate sources of radiated EM energy for the purpose of immediate threat recognition. ESM provides a source of EW information required to conduct ECM, ECCM, threat detection, threat warning, avoidance, and radar target acquisition homing. The primary role of ESM is a wartime function which provides the military commander a capability which can be integrated with other operational forces. During peacetime, ESM forces must be used with other military forces.

Exploitation of the EM environment requires timely interception and analysis of each transmission likely to contain information which can influence current or future operations.

To be most effective, SIGINT systems must exploit the signal environment before an engagement to assess enemy capabilities, locate threat systems, and determine technical parameters of transmissions. As the engagement progresses, stimulated by the presence of friendly forces,

significant events may occur within the enemy's system which permit SIGINT and ESM exploitation.

Thus, ESM provides not only information on the location of emitters, but also other information useful in reducing the effectiveness of hostile weapons and tactics. The application of techniques to degrade hostile electromagnetic EW - ECM.

ELECTRONIC COUNTERMEASURES (ECM)

ECM is defined as actions taken to prevent or reduce an enemy's effective use of the EM spectrum, primarily through jamming and deception. This section will discuss general types of both radar and communications ECM and also examine some related topics, including ECM antennas, concepts of employing ECM, self-protection, and support ECM. This brief look at ECM is designed to give the reader an introduction to the methods, types, and concepts of ECM used in a hostile environment.

ECM Antennas

An antenna is a device which efficiently couples EM energy in free space with a transmitter or receiver. ECM antennas can take many forms and sizes. Some small antennas use parabolic reflectors which rotate rapidly. Other antennas can tower over 100 feet high. Some antennas may be short stubs projecting from the side of an aircraft or even inconspicuous slots cut into the skin of an aircraft fuselage. This section presents the special requirements of ECM and the types of antennas used to meet these requirements.

ECM involves sending a signal from a transmitter to a victim receiver. Most antennas are generally of unidirectional construction. For aircraft applications, these antennas must be capable of being mounted externally. The blade/stub antenna meets these requirements (figure 4-6).

In some instances, directional antennas are used for jamming purposes. For directional jamming applications, horn or phased array antennas (figure 4-7) can be used to direct the maximum amount of jamming energy against the threat radar.

Polarization

Polarization refers to the orientation of the electrostatic field (E-field) with respect to the

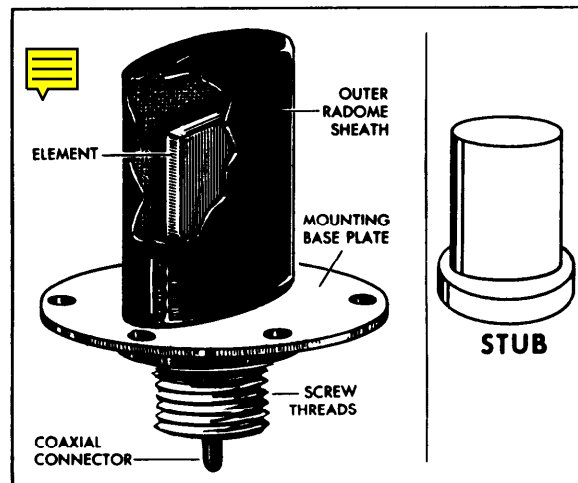

Figure 4-6. Stub/Blade Antenna.

surface of the earth. If a dipole antenna is erected vertically, it will radiate E-lines of force that will travel perpendicularly with respect to the surface of the earth. The dipole is then said to be "vertically polarized." If the dipole is oriented so the E-field is radiated parallel to the surface of the earth, the dipole is said to be "horizontally polarized" (figure 4-8).

A third type of polarization can occur where the E-field, instead of maintaining a constant orientation with respect to the earth, rotates about the line of propagation. This is called circular polarization and can be obtained by simultaneously feeding two dipole antennas, one-quarter wavelength apart.

Figure 4-9 illustrates right circular (CW) polarization because the resultant rotates to the right. If either wave was shifted 180 degrees, the polarization would then be left circular (CCW).

In this introduction to antennas, only transmission has been considered. The same type of antennas used for transmission may also be used for reception. Reciprocity is the characteristic of antennas that enables them to receive energy with the same relative efficiency at which they can radiate.

Antenna arrays employ the principle of arranging several antennas so that their radiated energy is reinforced in some directions and is cancelled out in other directions. Radiated EM energy adds and cancels like the two sine waves shown in figure 4-10.

Modern radar systems have increased needs for high gain antennas which are capable of high speed, wide angle scanning and simultaneous operation of multiple functions from a single

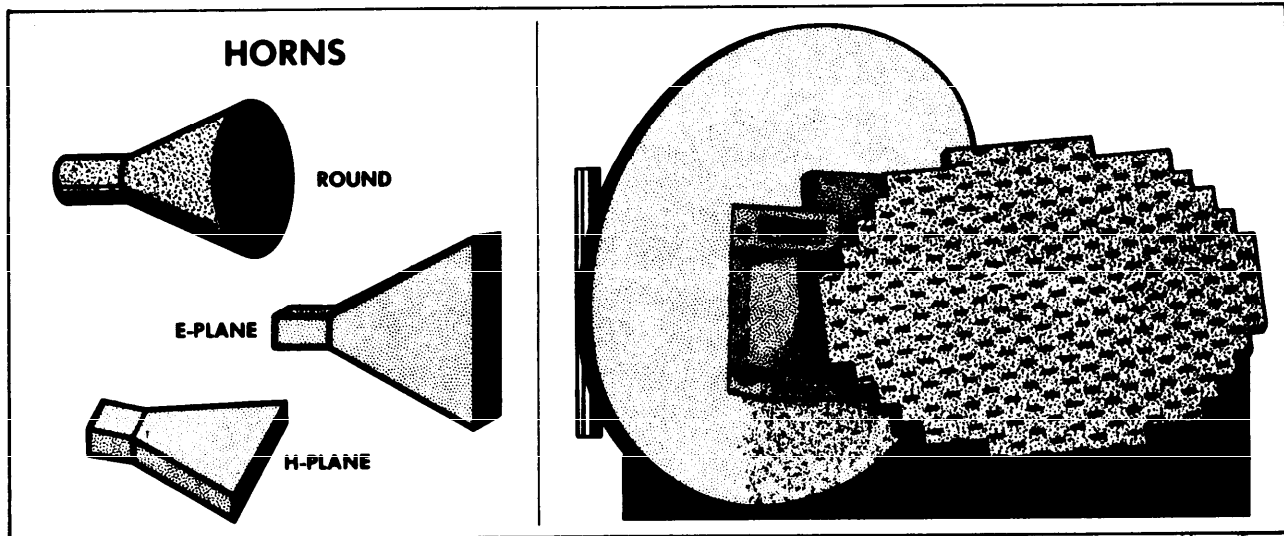

Figure 4-7. Horn and Phased Array Antennas.

antenna. A phased array can provide these capabilities.

A phased array is an arrangement of a large number of antenna elements. Common types include linear arrays (elements in a straight line), planar arrays (elements covering a planar surface), and curved and conformal arrays (elements on a curved line or surface). The linear array with equal spaced elements is easiest to analyze and forms the basis for most array designs.

Figure 4-11 illustrates a linear array. By controlling the phase of the signal delivered to each element, we can control the direction and shape of the beam radiated by the phased array.

The amplitude excitation can be varied to control side lobes and beam shape. All beam shapes (pencil or fan shaped) are possible in phased arrays. Linear arrays produce a fan beam. A planar array can produce a pencil beam or an elevation shaped beam. Shaped beams and low

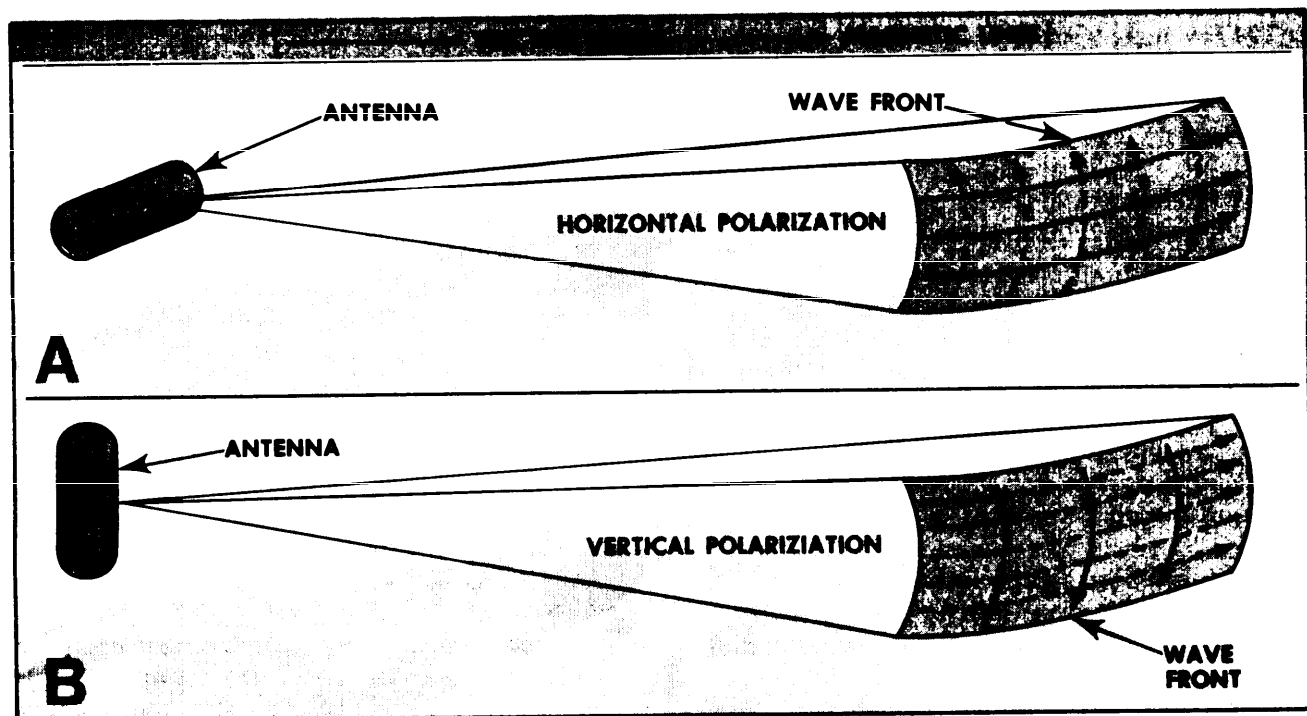

Figure 4-8. Vertical and Horizontal Polarization.

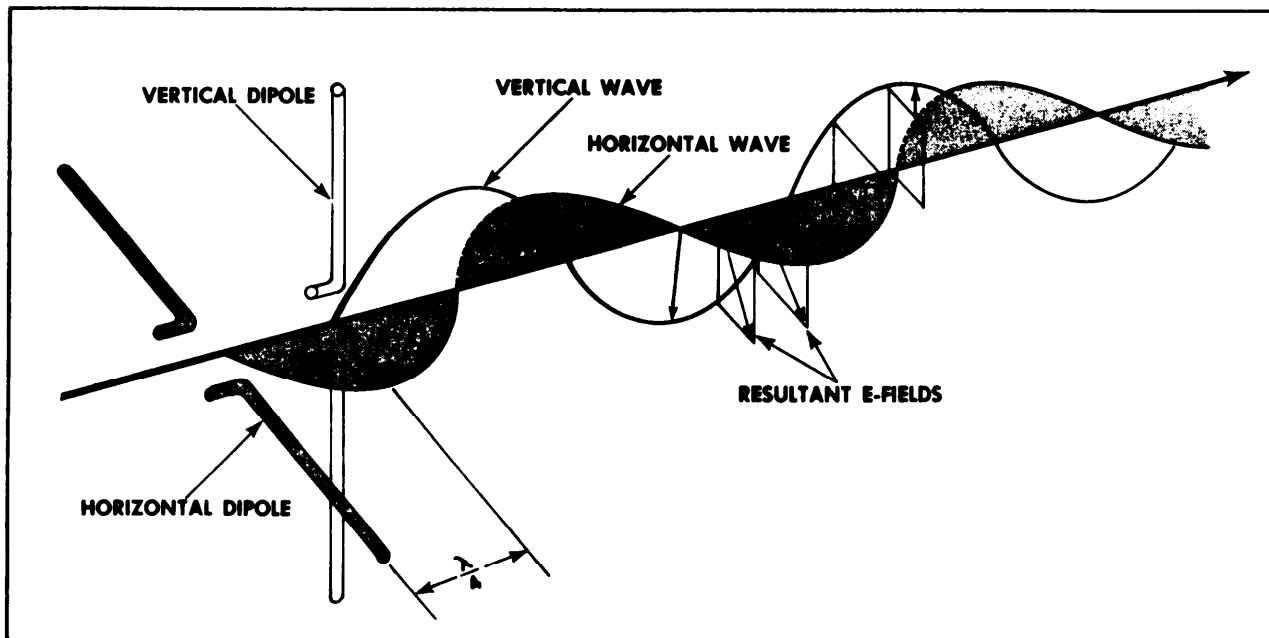

Figure 4-9. Circular Polarization.

side-lobe amplitudes are easily achieved in phased arrays because of independent amplitude and phase control on each element.

Phased arrays have been in use since WW II. The US Navy used a phased array fire control system (the FH MUSA) on large ships, and the AN/APQ-7 "Eagle" scanner was used aboard aircraft for ground-mapping and bombing. Both of these systems used mechanical phase shifters. The state of the art in phased array is represented by the FPS-85 Spacetrack radar at Eglin AFB. The FPS-85 has 5,776 transmitting antennas with 5,184 separate transmitters and 19,500 receiving

antennas with 4,660 randomly placed receivers. This radar is controlled by a digital computer. The FPS-85 can simultaneously search and track and can switch its beam from any point in its coverage to any other position within its coverage in less than 20 microseconds.

The phased array has four distinct advantages:

1. The beam may be rapidly scanned over the coverage of the antenna without moving the entire antenna structure. The beam may be scanned continuously or moved discreetly from one point in space to another.

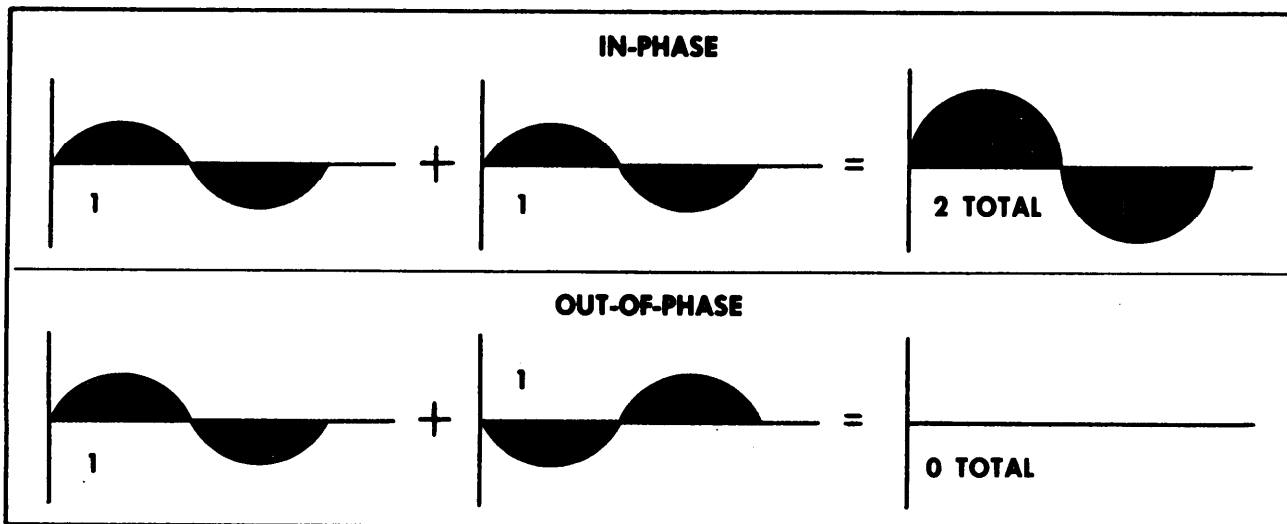

Figure 4-10. Phase Relationships.

2. The array has the ability to generate many independent beams simultaneously.

3. Large peak and (or) average powers may be obtained with separate transmitters at each of the elements of the array.

4. The steerable feature of an array means the beam from a shipborne or airborne radar may be stabilized electronically rather than mechanically by moving large structures.

Cost and complexity are the biggest disadvantages of the phased array. The cost of an array is roughly proportional to the number of elements. Another factor which contributes to the cost and complexity of an array is the need to maintain phase stability even under adverse operating conditions.

To be effective, an ECM antenna should have high gain to allow more power to be directed toward the victim emitter.

Antenna with a wide bandwidth can be employed across a wider frequency range. This can be quite valuable in counting tunable emitters. However, as the bandwidth of an antenna increases, its transmission efficiency decreases. For airborne applications, an ECM antenna should be small, streamlined, and durable.

An antenna that has seen wide airborne usage is the scimitar (figure 4-12). Physically, it differs

considerably from the blade, and electrically, it radiates in a much more directional pattern. It has great mechanical strength because it is large at the stress points, it can be fastened directly to the aircraft frame, and it presents a small cross-sectional area to the airstream.

A scimitar antenna acts as a quarter-wave stub. It yields a very wide bandwidth, is streamlined, and very sturdy. It is predominately used in vertical polarization applications.

The spiral is a wide bandwidth, circularly polarized, directional antenna (figure 4-13). One of its primary advantages is that it can be flush-mounted on an aircraft fuselage or wing. The helical antenna exhibits many properties similar to the spiral antenna and serves many of the same purposes (figure 4-13).

The antennas used in ECM are an extremely important part of the system. They serve as a coupling device—a “bridge” to couple free space energy to the transmission line of a receiver or, conversely, to couple the energy from the transmission line of a transmitter to free space. Since most antennas are externally mounted, they must be designed to withstand considerable stress. Since disturbance of the airfoil around an aircraft is always a prime consideration, antennas are usually designed to cover as wide a frequency

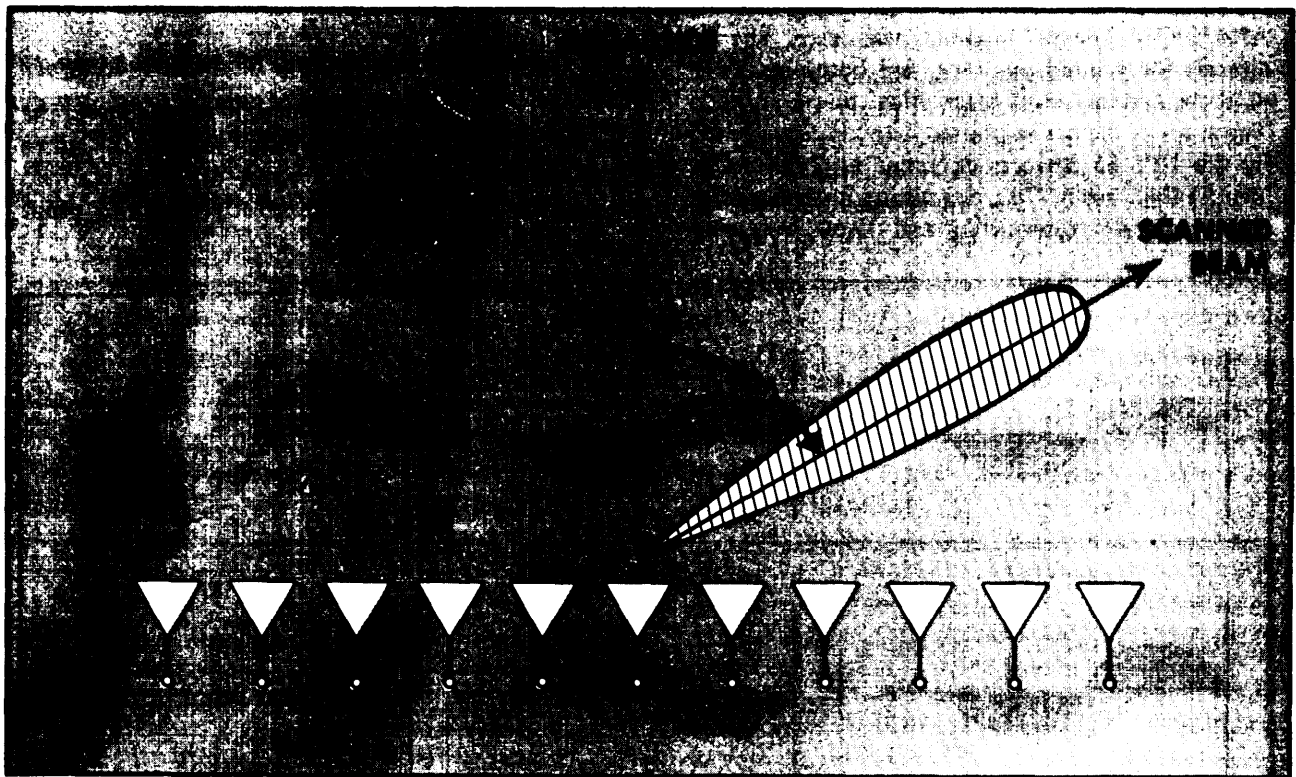

Figure 4-11. Linear Array.

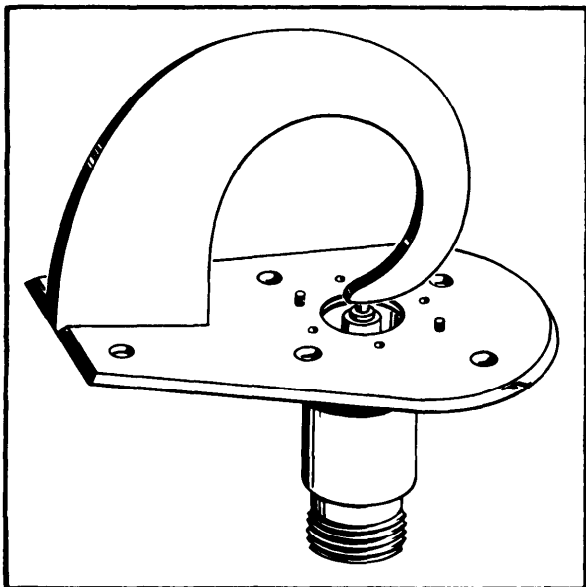

Figure 4-12. Scimitar Antenna.

spectrum as possible, thereby reducing the number of antennas required. In addition, the amount of power to be radiated is a consideration in the design of transmitter antennas.

Many kinds of antennas are in use. The antennas described here are representative of those generally found on operational ECM systems. Antenna design is constantly changing, with many new designs being introduced and tested.

Radar Jamming

An enemy's firstline defense against hostile aircraft begins with its EWR systems and is complemented by various other types of radars all the way to the target. As discussed in chapter 2, a wide variety of radars accomplish tasks that range from simple target detection to tracking targets and shooting them down. Because the radar has a high degree of accuracy and all-weather capability, it is a fundamental requirement of a good defensive system, and any actions that penetrators can take to counter radar significantly improve both survivability and probability of successful mission accomplishment. One such action is denying information to a radar through the use of jamming. Jamming is the radiation or reradiation of signals to interfere with the operation of a radar receiver. One jamming method used is the transmission of noise, while another is the transmission of a series of pulses. Whichever method is used, the purpose of jamming is to create confusion and deny information, thus degrading an enemy's defensive

capabilities. An electronic device designed specifically for jamming is a RF transmitter called a "jammer." Some concepts basic to jammers are discussed in the next few paragraphs.

Matching Radar Frequencies

A jammer's RF output must match the RF of a radar in order to introduce interference on that radar's scope. This is analogous to a home radio receiver. If reception from a particular radio station is desired, the receiver must be tuned (aligned in frequency) to the frequency that the radio station transmits. Likewise, if a jamming signal is not matched to the frequency of the radar to be countered, the jamming signal will not be received and displayed on the radar's scope.

Continuous Interference

A jamming noise transmitter should produce continuous interference in order to be effective. In much the same way that intermittent static on a home radio receiver does not completely block out a program, intermittent jamming on a radar does not completely block out a target information. An experienced radar operator can derive all the desired target information even if allowed only short breaks in the jamming affecting the radar.

Given these two requirements, an ECM operator has a significant problem: On any given mission, there are many radars to be countered in many different frequency ranges. Just as there are many commercial radio stations in an area that are operating at different frequencies, there are many radars in an air defense system operating at different frequencies.

To counter all components of a defensive system, including early warning search radars, HF radars, communication links AAA radars, and AI radars, intruding aircraft must carry jammers which can operate throughout broad frequency bands.

Search radars generally operate at lower frequencies in relation to the entire radar frequency spectrum. This is necessary to achieve high output power and accomplish long-range target detection and tracking. Ground-to-ground and ground-to-air communication links also operate in the lower ranges. Radars which control weapons (missiles or anti-aircraft guns) generally operate at higher frequencies to achieve better accuracy in target tracking, which is required for placement of projectiles within lethal range of target aircraft.

External Factors Affecting ECM

There are many factors which affect the effectiveness of jamming. Some of these factors, such as atmospheric attenuation of signals, tropospheric scatter, and other temperature/weather associated phenomena, are unpredictable and extremely difficult to quantify. Other factors, such as the three discussed below, are theoretically predictable and easier to quantify.

1. Burn-Through Range. Since jamming signals are one-way transmissions, they enjoy a distinct power advantage over radar reflected energy at most ranges; however, as a jamming aircraft approaches a radar site, its jamming power increases by the square of the distance, whereas, the echo power of the radar increases by the fourth power. Therefore, at some distance between the aircraft and the victim radar, the echo's power is greater than the jamming signal and the victim radar is able to "see through" the jamming. This distance is referred to as the "burn-through range." The ground radar's peak power (which is usually significantly greater than that part of an airborne jamming transmitter) and the power of the jammer both play an important role in determining this range. The variation with range of signal power versus jamming power is plotted on the graph in figure 4-14 to illustrate burn-through range.

2. Victim Radar Characteristics. Another major variable contributing to the effectiveness of jamming is the specific characteristics and

capabilities of the ground-based radar. These characteristics and capabilities are based on the radar's operating parameters and on the various "antijamming" (ECCM) circuits incorporated in the radar's design. These ECCM circuits will be covered later in this chapter.

3. Jammer Characteristics. Because there are many radar types which must be countered when penetrating a hostile environment, different types of jamming and jammers must be employed. These different types of jamming may be divided into two categories: noise jamming and deception jamming (sometimes called "spoofing"). The power of a jammer, though important, does not totally determine the effectiveness of that jammer against a radar. The type of jamming used can be just as significant.

Noise Jamming

Noise jamming is produced by modulating an RF carrier wave with noise (random amplitude changes) and transmitting that carrier wave at the victim radar's frequency. Because a radar receiver uses extremely weak echo pulses reflected from a target, it must be extremely sensitive. This extreme sensitivity makes the radar highly vulnerable to noise jamming since the jamming signal is usually of far greater amplitude than a returning echo signal from a target. For a radar to detect a target, the amplitude of the returning signal must be greater than the amplitude of ambient noise. This is expressed mathematically

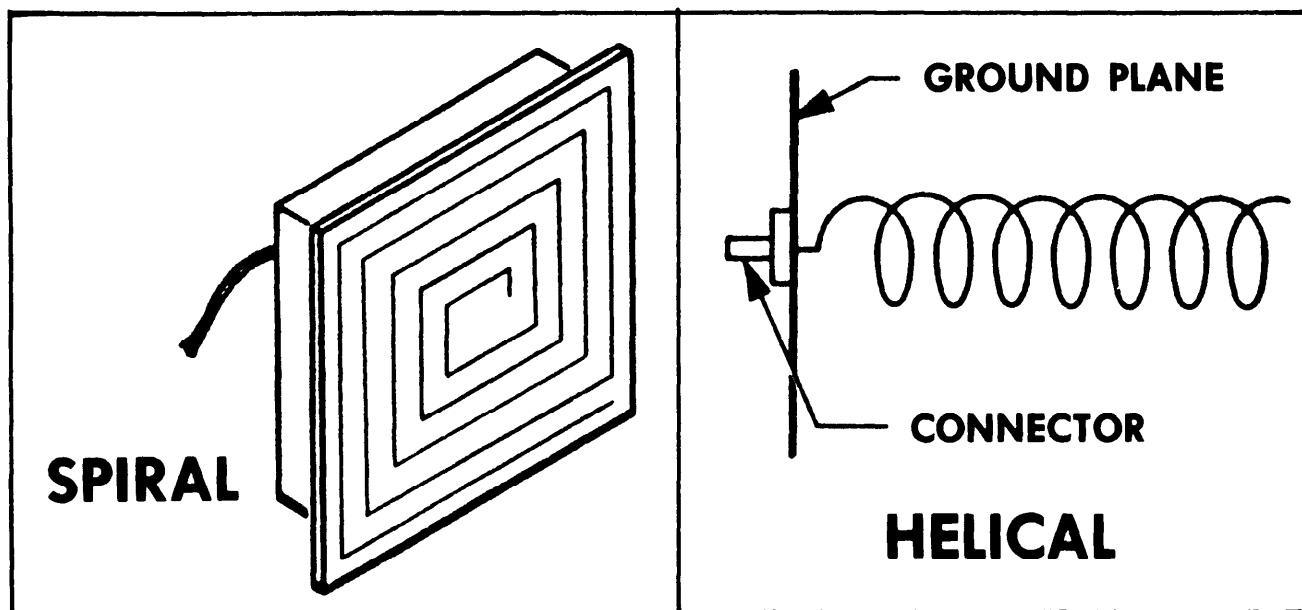

Figure 4-13. Spiral Antenna and Helical Antenna.

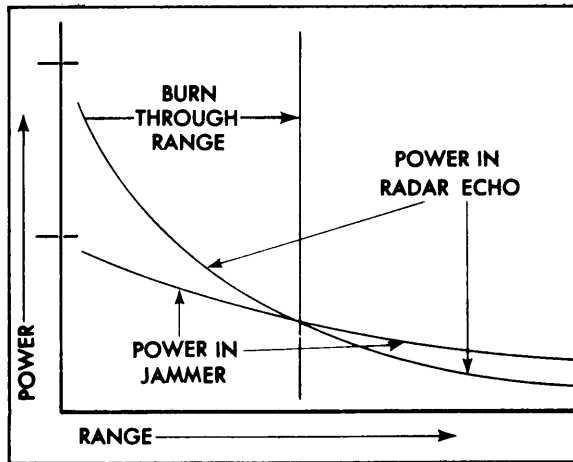

Figure 4-14. Burn-Through Range.

by a ratio known as the "signal-to-noise (S/N) ratio" (sometimes called the "signal-to-jam ratio (S/J).") For any signal (target return) to be detectable, the S/N ratio must be greater than one ($S/N > 1$). If the S/N ratio is less than one ($S/N < 1$), the target return is lost in the ambient noise and position information cannot be obtained. Figure 4-15 shows a target displayed on a scope in an environment where $S/N > 1$, while figure 4-16 shows the effects of noise jamming

producing a $S/N < 1$. Effective jamming results when a S/N ratio is less than one.

To increase the effectiveness of noise jamming, the noise signal can be injected into the radar's side lobes or further modulated to create deception-like jamming effects. The objective of jamming the side lobes of a search radar is to make a large sector of the indicator unusable. This will mask targets on azimuths different from that of the jamming aircraft because the jamming that enters a radar's lobe will be displayed in the direction the radar's main beam is pointing when the jamming signal is received on the scope. As the antenna rotates, it is possible to put jamming strobes 360 degrees around the radar operator's scope.

Noise jammers can be divided into three major categories: spot jammers, sweep jammers, and barrage jammers.

Spot Jammers

The two major advantages of spot jamming are its high-power density (determined by dividing total bandwidth into total power) and its continuous coverage of the victim radar. Spot jammers are normally employed where high power concentration against one particular fixed frequency radar is desired.

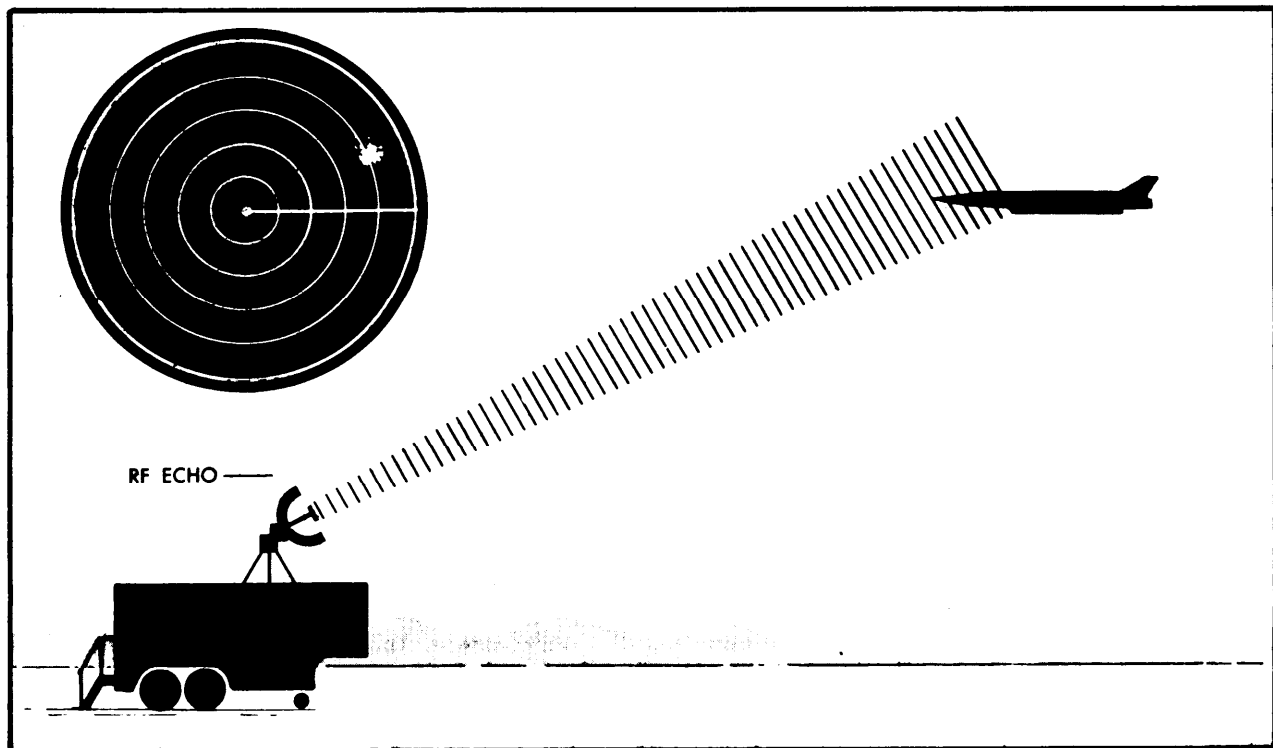

Figure 4-15. Radar Scope Without Jamming.

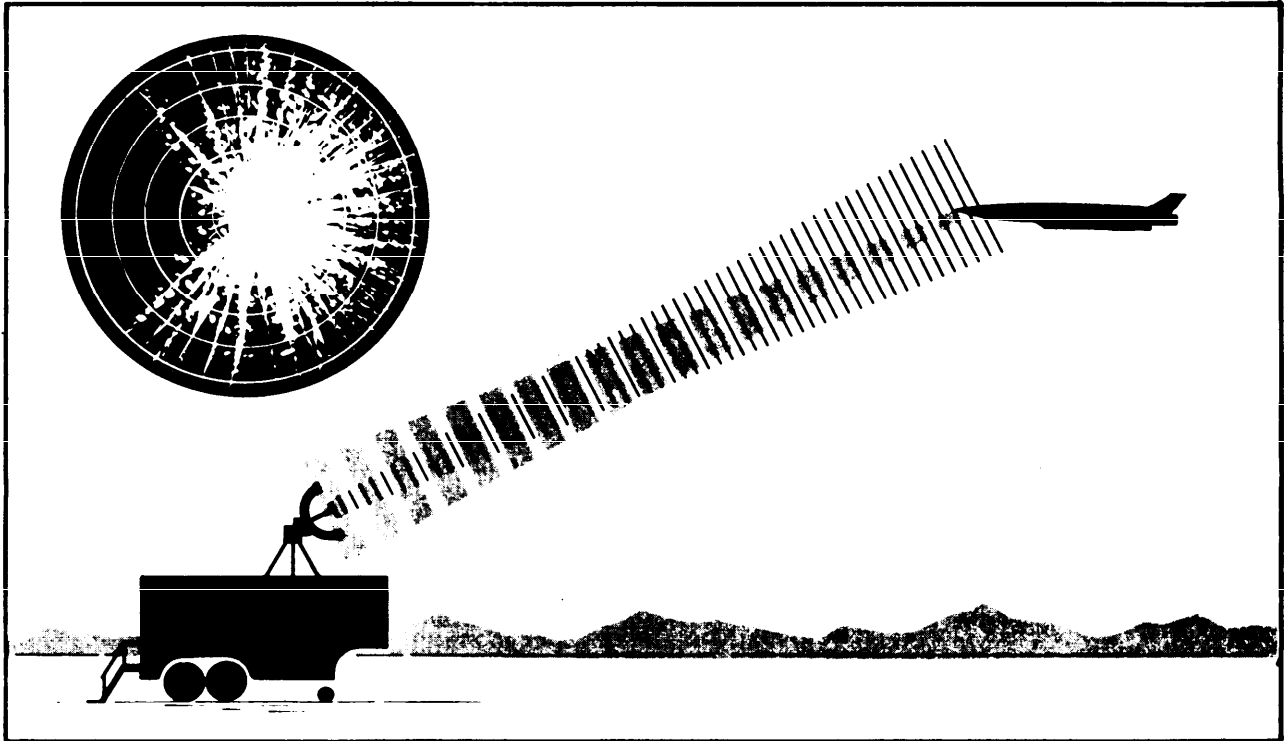

Figure 4-16. Radar Scope With Jamming.

The earliest jammers were narrow bandwidth (generally 10 MHz or less) spot jammers. This type of jammer is manually tuned to the frequency of the victim radar signal (figure 4-17). (In areas where several radars were operating simultaneously at different frequencies (frequency diversity), a separate spot jammer would be required to jam each individual radar. Aircraft weight and space restrictions may not always allow enough spot jammers to be carried to cover all of the enemy radars that could be encountered on a mission. Also, radars which can rapidly change their operating frequencies (frequency agility) may change frequencies quickly enough to get away from the spot jamming signal).

Sweep Jammers

Where high-power density is desirable over a wideband, spot jamming must be replaced by sweep jamming. Sweep jammers tune a narrow-band jamming signal (spot jamming signal) across a broad frequency band at rates varying from slow to extremely fast. By tuning the jammer back and forth over the desired band, all preset victim radars are affected by the jamming (figure 4-18 (A)). The advantage of sweep jamming is that all radars get some coverage by high-powered

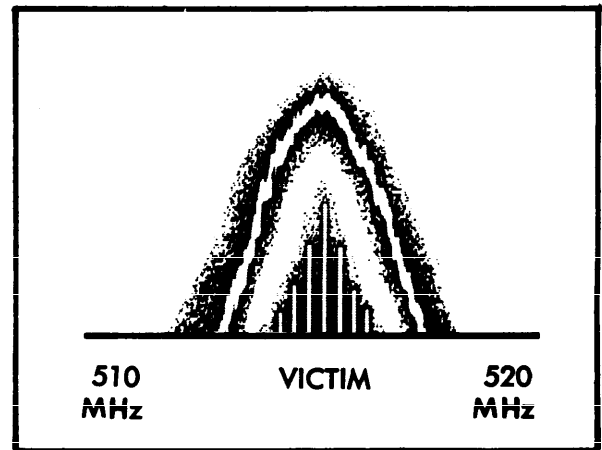

Figure 4-17. Spot Jamming.

dense jamming, but the disadvantage is that the jamming is not continuous. However, fast sweep jamming (sweep jamming at a fast rate) can approximate continuous coverage by causing a phenomenon known as "ringing." Most radar receivers have highly sensitive amplifiers which, when flooded with a high-powered burst of energy, continue to oscillate for a short period of time. This is somewhat like two tuning forks of the same frequency. If one of the forks is struck,

it will vibrate and cause a similar vibration in the other fork. The second fork will continue to vibrate for a short time even if the first fork is grasped and made to stop vibrating. Fast sweep jamming approximates a burst of energy and causes oscillation in the receiver's amplifiers which lasts, if effective, until the sweep jammer once again passes the radar's frequency and sustains the oscillation. A block diagram of a noise modulation jammer used for either spot or sweep jamming is shown in figure 4-18 (B).

Barrage Jammers

In applications where high-powered density must be sacrificed for continuous coverage of the victim radars, barrage jamming may be employed. Barrage jammers are wideband noise transmitters designed to deny use of frequencies over wide

portions of the EM spectrum. The use of this type of jammer is attractive not only because a number of enemy receivers can be jammed simultaneously, but also because frequency agile radars can be jammed without readjusting the jamming frequency. Basic barrage jamming is illustrated in figure 4-19 (A). As shown in figure 4-19 (B), the disadvantage of barrage jamming is that its power density is inversely proportional to bandwidth. A block diagram of a barrage jammer is shown in figure 4-20.

Modulated Noise Jammers

Modulated jammers are a special type of noise jammer that is primarily used to "break lock" or to deny tracking capability to a tracking radar. Two types of modulated jammers are those used against TWS and those used against conical scan

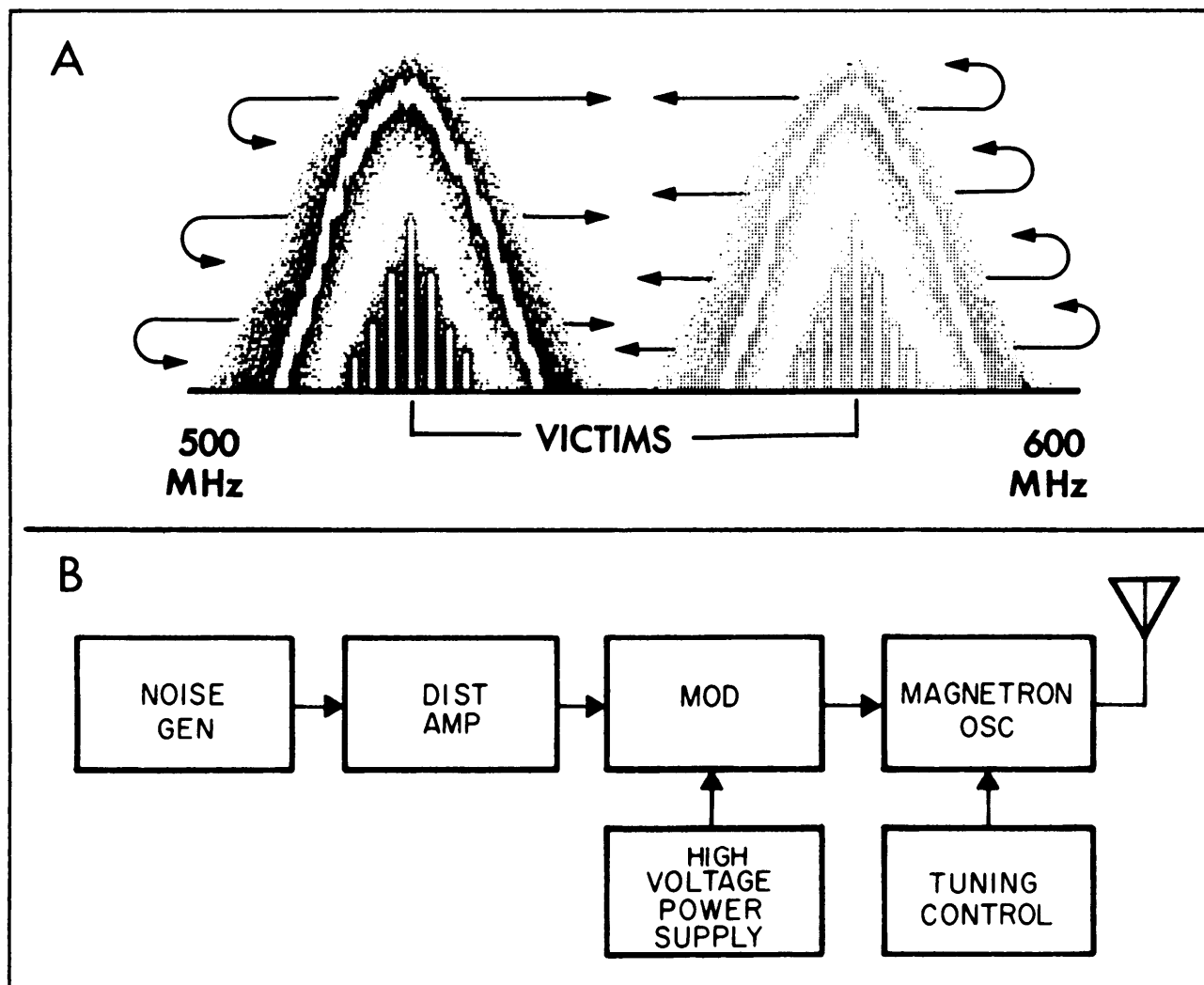

Figure 4-18. (A) Sweep Jamming and (B) Noise Transmitter.

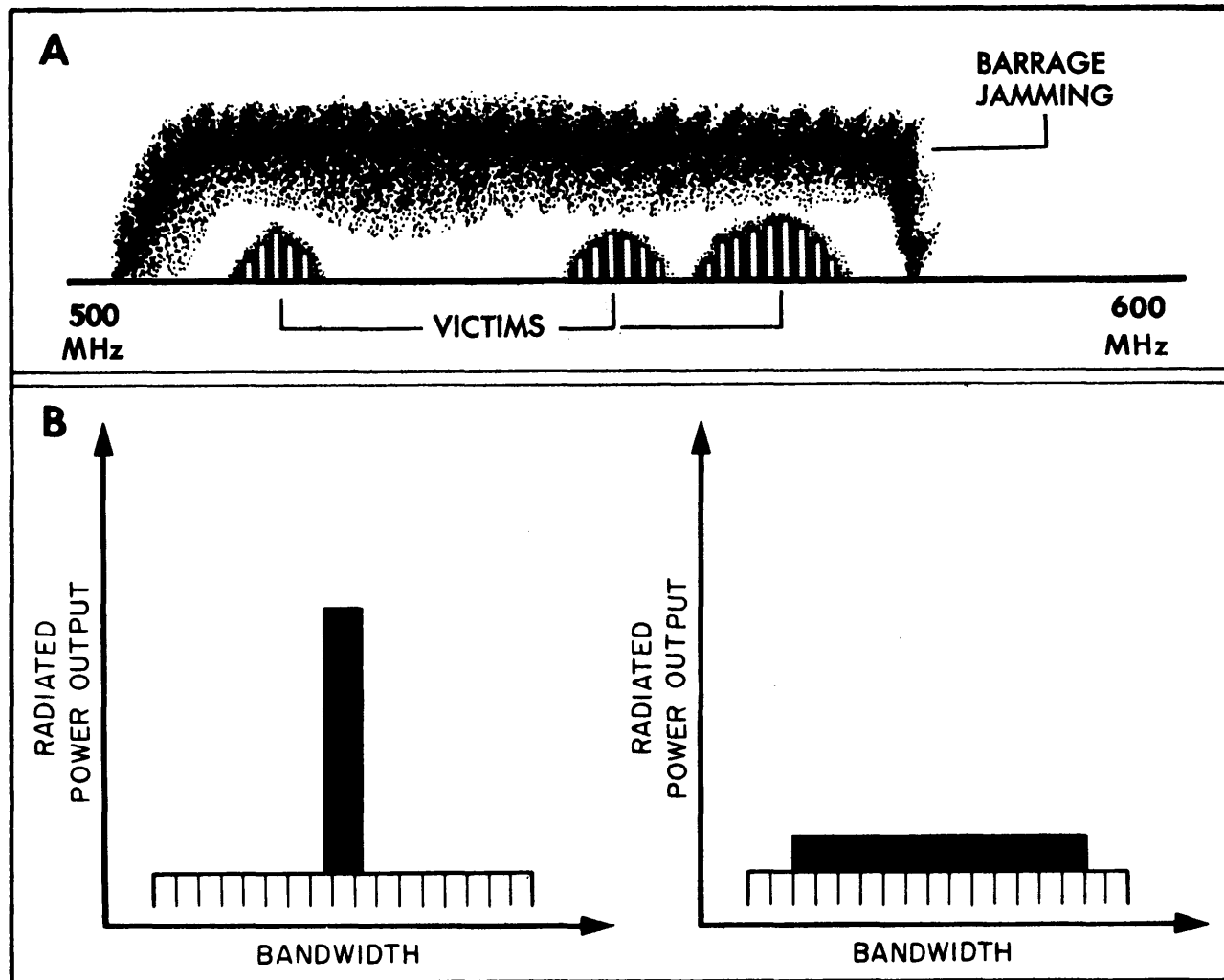

Figure 4-19. (A) Barrage Jamming and (B) Jamming Power vs Bandwidth.

(see chapter 2 for an explanation of these radars). In both types, an amplitude modulating signal is fed into the jammer which alters the amplitude of the jamming output at a frequency that is related to the scan rate of the tracking radar. A sine wave modulated signal may be used against conical scan. The frequency of the sine wave is just slightly higher (by 3 to 4 Hz) than the scan rate of the conical scan. The result is a continuously varying phase difference between the radar and jammer which results in the generation of a false tracking error signal (figure 4-21). This results in "angle walk off" which causes the conical scan radar to "lose sight" of the real target.

A pulse-modulated rectangular waveform signal is used to modulate the jammer used against TWS. The PRT of the modulating signal (PRF measured in PPS) is set at some whole number multiple (harmonic) of the TWS rate. This synchronization

produces a number of lines across the TWS scope, each one at either a different azimuth or a different elevation (depending upon which beam of the TWS is being jammed). The total number of lines is a function of the harmonic of the scan rate to which the modulating signal is set. For example, a modulating signal frequency that is four times the scan rate of the TWS results in four lines being displayed on the scope as shown in figure 4-22. Any slight lack of synchronization results in a "rolling" of the lines on the scope which is confusing to the radar operator. The block diagram of a basic modulated transmitter is shown in figure 4-23.

Deception/Confusion Jamming

The types of plain noise jamming discussed so far transmit unintelligible noise. Their purpose is

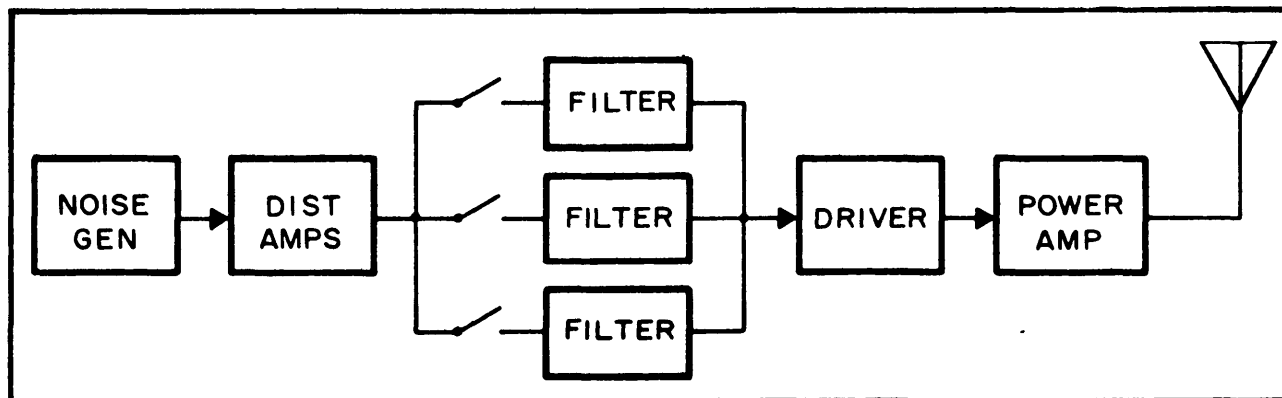

Figure 4-20. Barrage Transmitter.

to create strobes of jamming (noise) on the radar scope and, thereby, hide the true target echo to deny the enemy range information. However, the noise strobes do not deny angle information since the center of the main jamming strobe is coincident with the actual horizontal and vertical direction to the jammer producing the strobe. This azimuth and elevation information is sufficient to allow missile guidance by a terminal defense system (those radars used to protect strategic targets). For this reason, plain noise jamming is not totally effective against terminal threat radars.

Modulated noise jamming uses a jamming program based on the threat radar's approximate scan rate. It is more effective than straight noise jamming against threat radars, but because it may not operate on the exact scan rate, its effects often are not as pronounced as they could be.

Deception/confusion jammers are highly complex devices that process received radar energy

and retransmit it to appear as a true target on the radar scope. Knowledge of the range, angle, and velocity tracking capabilities of the radar receiver is desired in order to program the deception/confusion jammer. Deception/confusion jammers usually operate by receiving the radar pulse of energy that strikes the aircraft, amplifying it, modulating it, delaying or augmenting it, and retransmitting the altered signal to the radar. The results are false targets (confusion), tracking gate pull off, or azimuth/elevation position displacement (deception).

A false target generator transmits radar pulses that appear as real targets on a radar scope. The false targets can be positioned in front of or behind the target aircraft by varying the amount of time by which the false target pulses are delayed. The false targets can be made to appear at azimuths other than that of the jamming aircraft by transmitting the false target pulses into

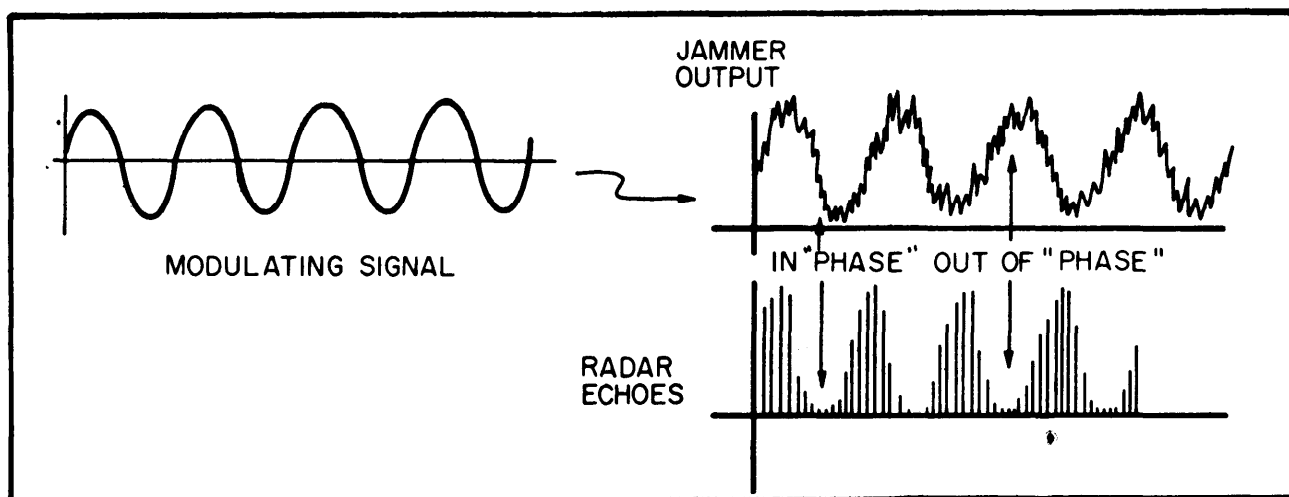

Figure 4-21. Modulated Jamming (Conical Scan).

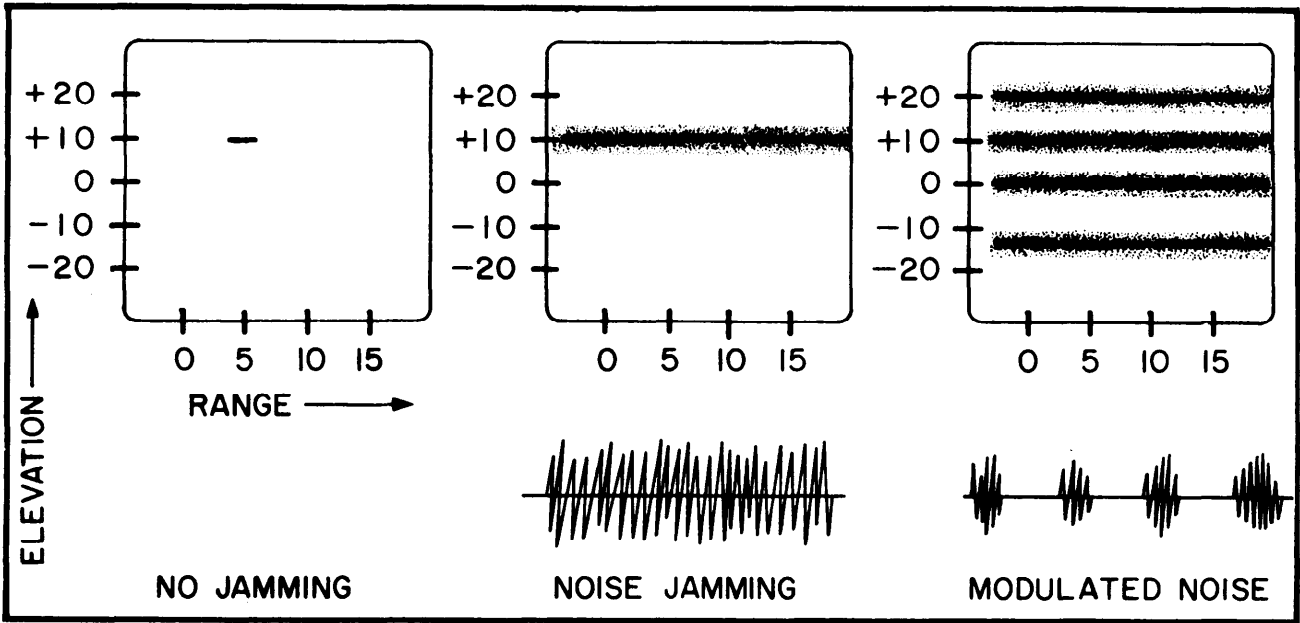

Figure 4-22. Track-While-Scan Jamming.

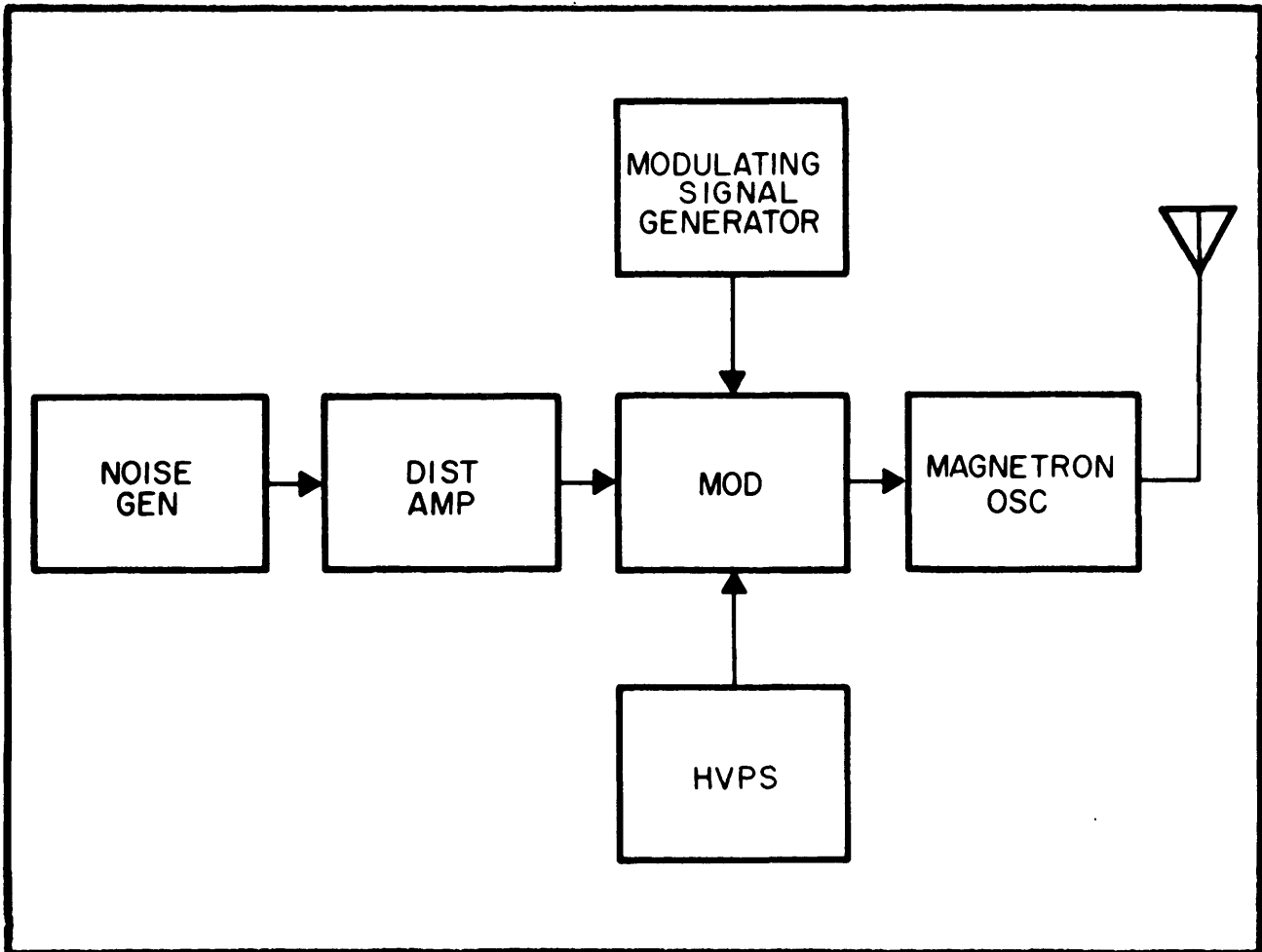

Figure 4-23. Basic Modulated Transmitter.

the radar's side lobes. Multiple targets can confuse the operators by preventing them from determining the actual number and position of real targets.

Range Deception

Range deception jamming takes advantage of any built-in weakness in the radar's range gate tracking circuits. With this technique, the jammer initially receives, amplifies, and retransmits the radar's signal. The jammer's signal appears on top of, and strengthens, the radar's reflected return. In the radar's range-tracking circuit, there is an automatic gain control (AGC) to lower the circuit's gain. The range circuit, with the lowered gain, will then only see the jammer signal and not the radar return. In effect, the range gate is captured. The subsequent pulses from the radar are received, amplified, and retransmitted with an increasing time delay, as shown in figure 4-24 and 4-25. The victim radar perceives this as increasing target range and "walks" the range gate off of the true target. After a set time period, the jammer repeats the entire process.

Angle Deception

Angle deception jamming is useful against sequential lobing (receiving returns successively from several antenna beams or "lobes") and conical scan tracking radars. It may consist of amplitude modulating a noise jammer or using a repeater jammer with a modulating program. Figure 4-26 illustrates a repeater jammer which senses the amplitude of the radar pulses and amplifies the weaker pulses much more than the stronger pulses. When these pulses are retransmitted, the radar will receive pulses which have amplitudes that are opposite those of the true pulses. This system gives the radar's angle tracking

circuitry false correction signals and results in angular break-lock or "angle walk-off."

Expendables

The discussion of ECM devices up to this point has centered around onboard active jamming systems. With the development of modern air defense systems such as those encountered in the 1973 Middle East War and deployed in many countries today, a mixture of penetration aids is required to confuse and degrade enemy radar defenses. To meet this requirement, expendable ECM devices, including chaff, decoys, and flares, have been developed. Flares are actually an infrared countermeasure (IRCM) and will be discussed as part of electro-optics (EO) later in this chapter.

Chaff

Chaff is an extremely effective ECM device. The overall success of the use of chaff in WW II was difficult to evaluate while the war was in progress; however, at the close of the war, an investigation was made to determine the effectiveness of this ECM program. The Germans admitted that chaff was extremely effective, with radar controlled anti-aircraft fire accuracy reduced as much as 75 percent.

The weight and volume of chaff used in WW II was excessive in terms of modern requirements since early chaff was made from metal-coated paper strips that were scattered in large numbers from bomber aircraft. Much R&D effort has been expended to reduce the size and weight of chaff and to increase its effectiveness. Today, chaff is made of strips of aluminum coated nylon or fiberglass, which is packaged in small units, light enough to allow an aircraft to carry and dispense large quantities during a sortie.

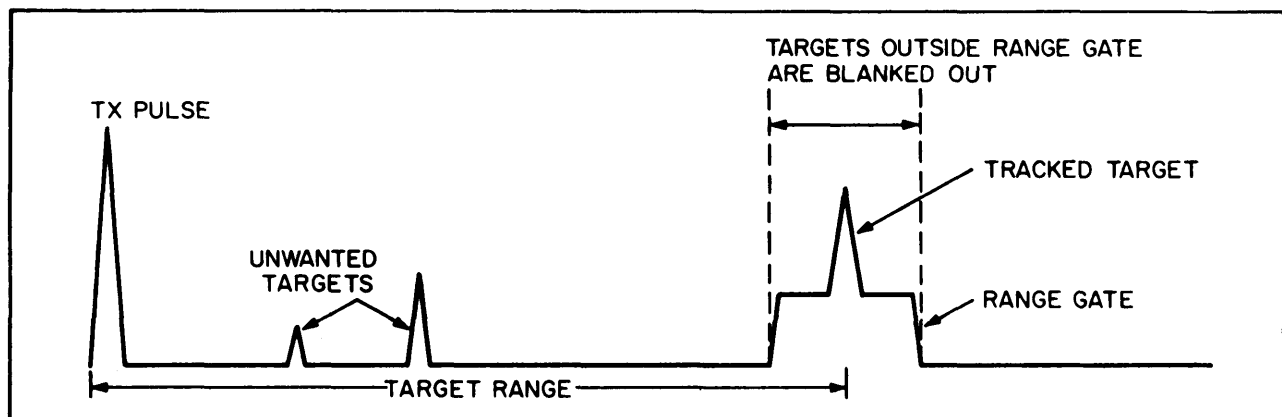

Figure 4-24. Range Gate Tracking.

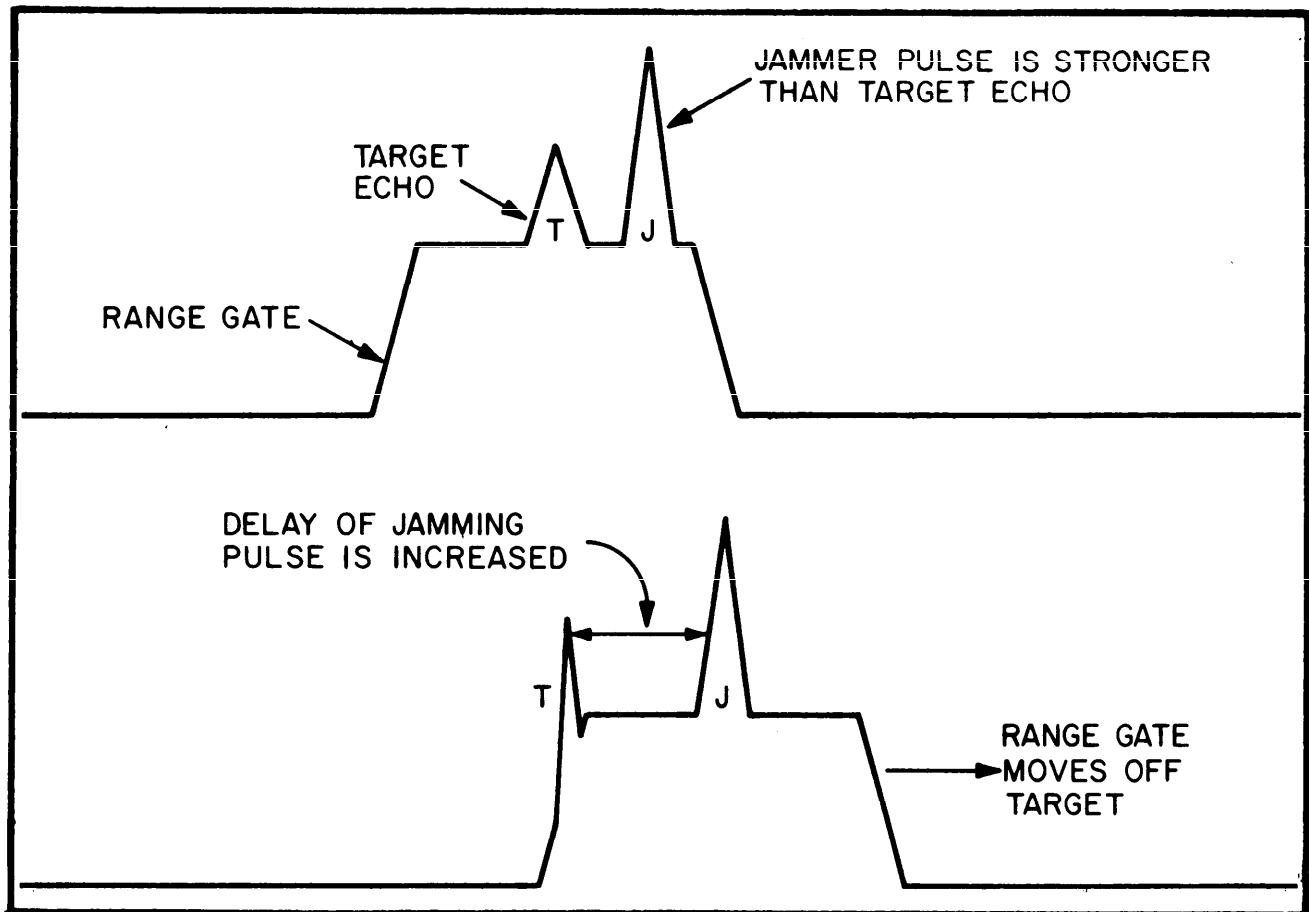

Figure 4-25. Range Gate Stealer.

How Chaff Works

Chaff consists of a large number of dipole elements designed to match the half wavelength of a victim radar's RF. It absorbs and reradiates EM energy to create a radar echo. Since the chaff strips are cut to one-half of a wavelength, they are very efficient reradiators. One small bundle of chaff can cause a much larger radar return than that produced by an aircraft.

Chaff is made to respond to a wide band of frequencies by simply packing different lengths of dipoles in the same bundle. This allows the chaff to be effective against more than one RF. Chaff is used to assist aircraft in penetrating a radar network by creating a multitude of misleading targets or a large area of solid radar returns which confuse and mislead radar operators. Even though the radar may locate the target, the addition of chaff can induce radar range tracking errors or cause a break lock.

Operational Uses

Chaff has two operational uses: a penetration aid and a defense against tracking threat radars. When used as a penetration aid, chaff may be dispensed in large quantities for a continuous period of time by chaff configured aircraft or by drones. This results in a "ribbon" return many miles in length on radar scopes. The penetrating strike force can then use the resulting chaff corridor to mask their route (figure 4-27).

Another method of dispensing chaff as a penetration aid is to drop it in small bursts at random intervals from all penetrating aircraft. This causes the defense radars to be saturated with many false targets. "Random chaff" tactics include chaff which is displayed at the same altitude as the penetrating force and delayed opening chaff which is deployed at lower altitudes. Weapons systems may be committed against these false targets (figure 4-28).

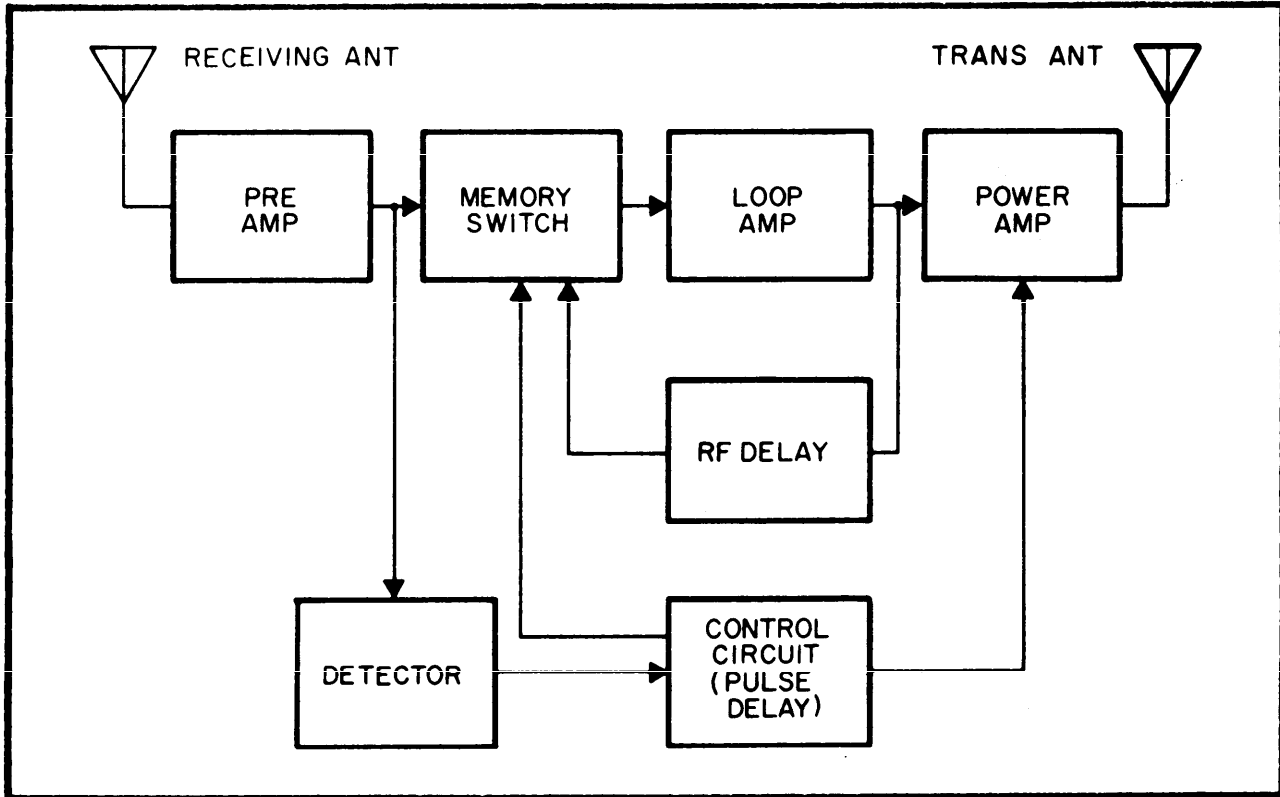

Figure 4-26. Repeater ECM Transmitter.

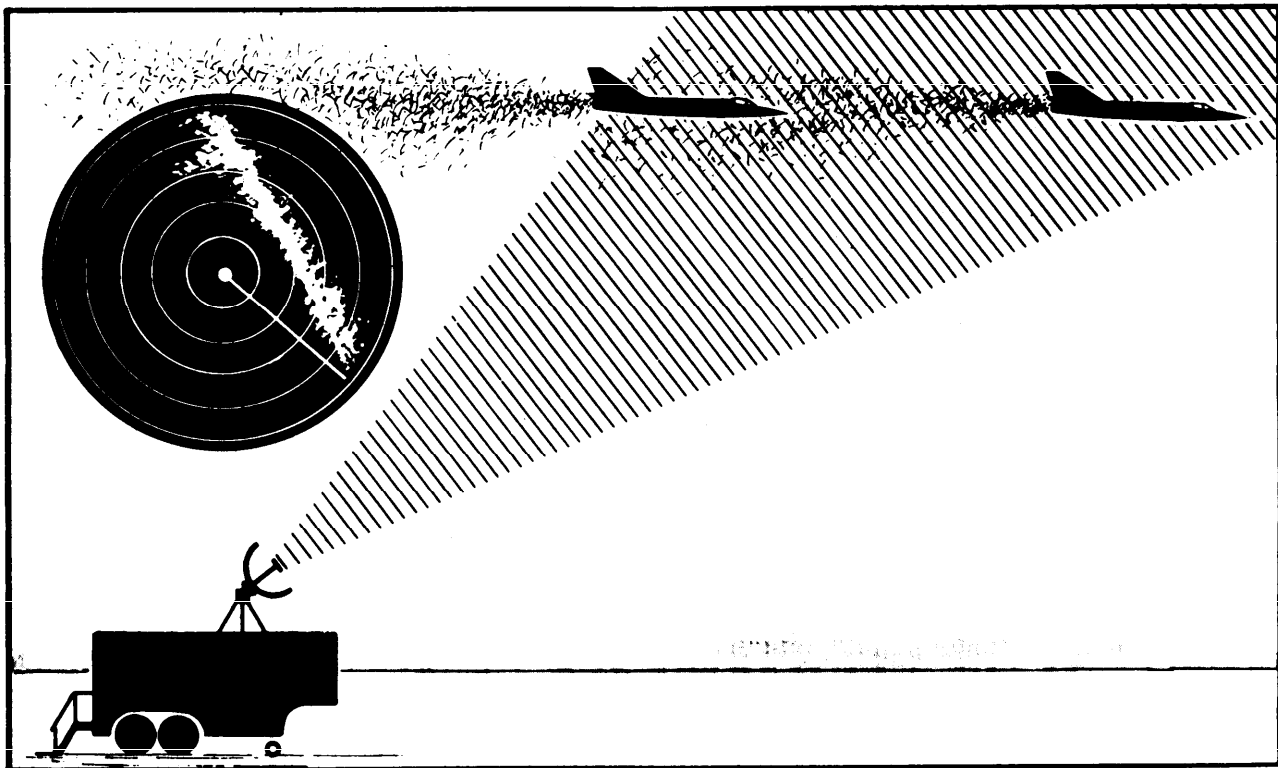

Figure 4-27. Stream Chaff Dispensing.

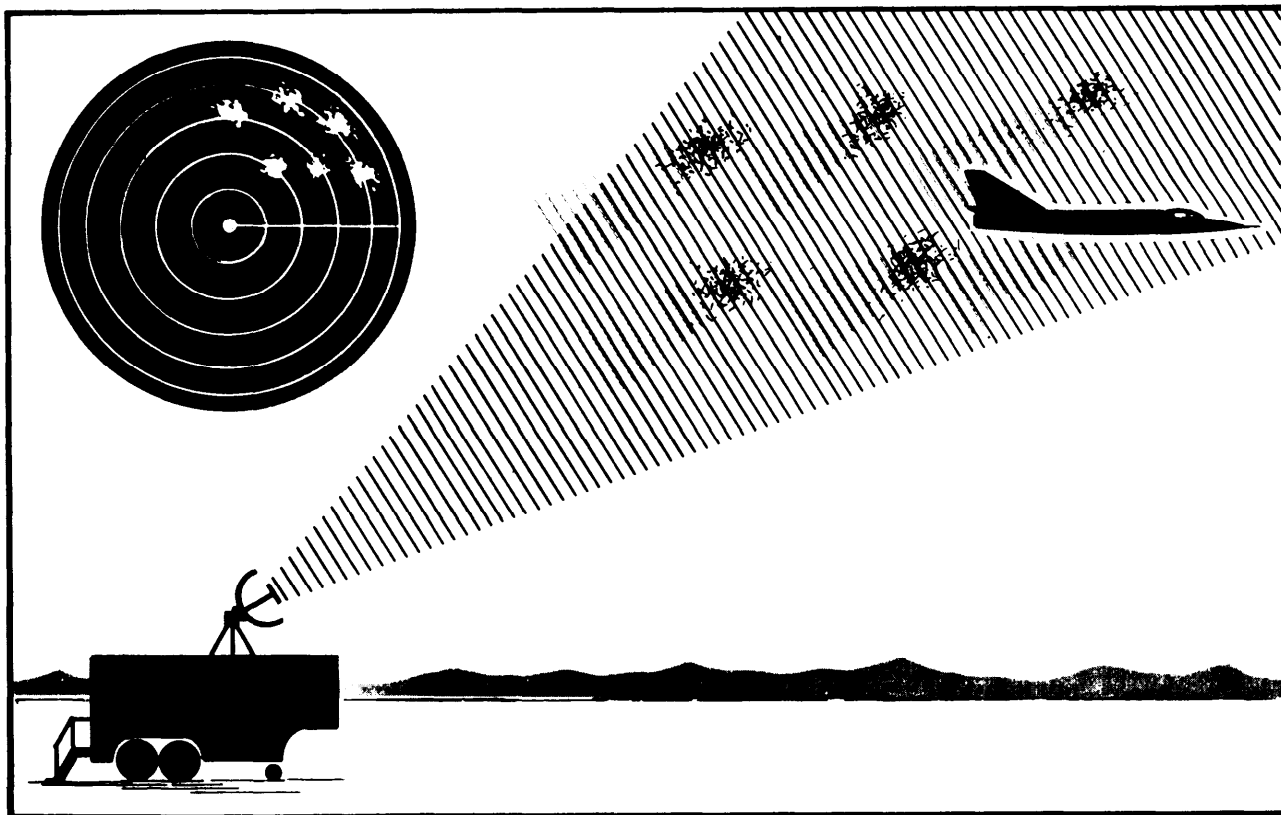

Figure 4-28. Random Chaff Dispensing.

The second role of chaff is for self-protection against terminal threat radars. Burst chaff drops employed during the final phase of intercept by air or ground weapons systems can induce large tracking errors or cause the radar to break lock (figure 4-29). Self-protection chaff drops are especially effective when combined with evasive maneuvers.

Decoys

A decoy (figure 4-30) is an expendable aircraft-like vehicle (ground) launched or deployed from a penetrating aircraft to provide deception and to create saturation of a defense network. Decoys can be made to be indistinguishable from the launch aircraft by the addition of corner reflectors which provide an echo return similar in intensity to the penetrating aircraft. Decoys can also be outfitted with chaff and small noise jammers to mimic penetrating aircraft ECM, or with repeater jamming to produce a radar return equal to the target aircraft. By duplicating the speed, altitude, and course of a penetrating aircraft, a deceptive target can be introduced into the enemy's radar defense system. This can draw fire away from the strike aircraft and degrade an enemy's air defense system.

Basic Principles of Employment

When enemy air defenses have to be penetrated, EC must be employed. One method of employment is to destroy or suppress enemy radar activity (SEAD). Another method is to employ jamming, deception, and expendable devices to counter enemy radars by denying them information. A third way to reduce the enemy's air defense system effectiveness is through the use of avoidance/evasion techniques.

Avoidance/Evasion

Evasion requires a penetrator to overfly, underfly, or fly around (avoid) an enemy's defense. When this is possible, it is an effective, positive countermeasure; however, the deployment of sophisticated high performance radars and SAMs has made the technique of overflying practically impossible. Further, it may not always be possible to fly around defended areas because of long-range radars and targets which lie within heavily defended areas.

Visual and terrain-following radar (TFR) assisted low level penetration tactics may permit strike aircraft to underfly the enemy's radar coverage as shown in figure 4-31. Also, the

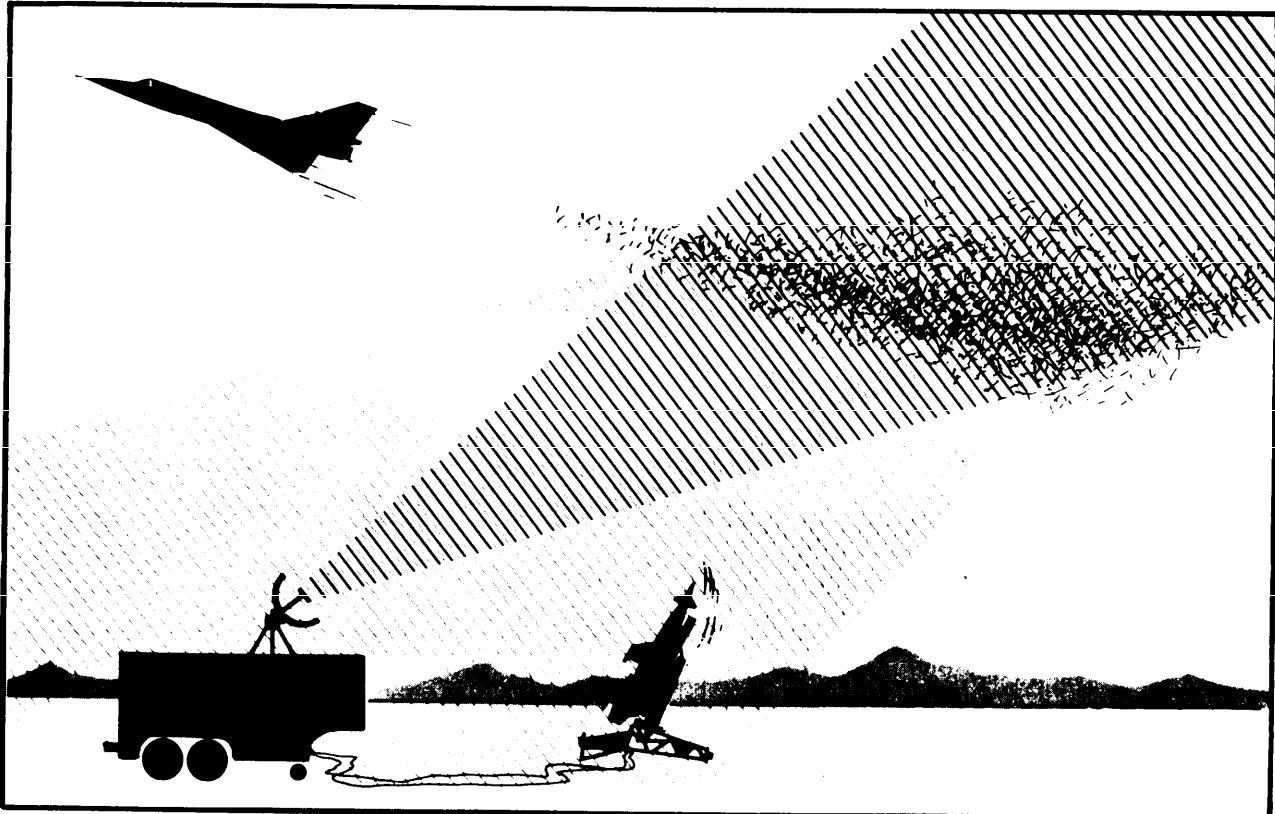

Figure 4-29. Burst Chaff Dispensing.

penetrator can take advantage of "shadow areas" created by mountain ridges or other terrain features. This is commonly known as "terrain masking."

In addition to preplanned tactics, frequent (en route) changes of altitude, heading, and airspeed ("jinking") will degrade target tracking radars. Computers associated with weapons are unable to

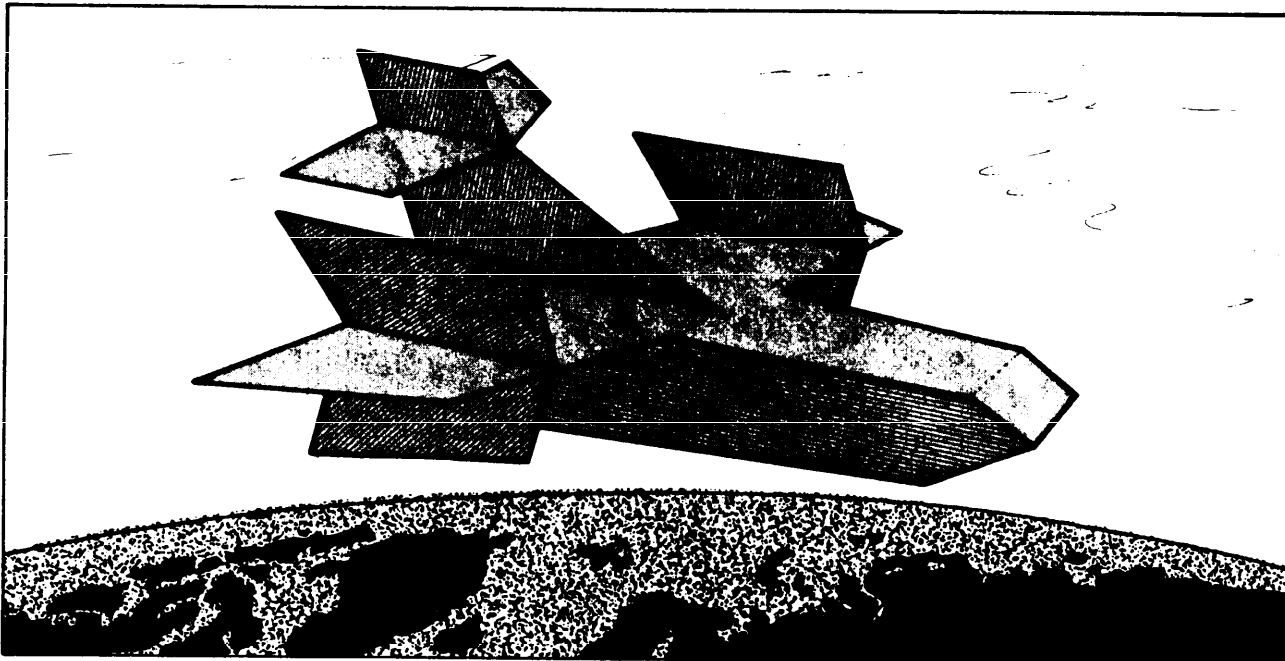

Figure 4-30. Decoy.

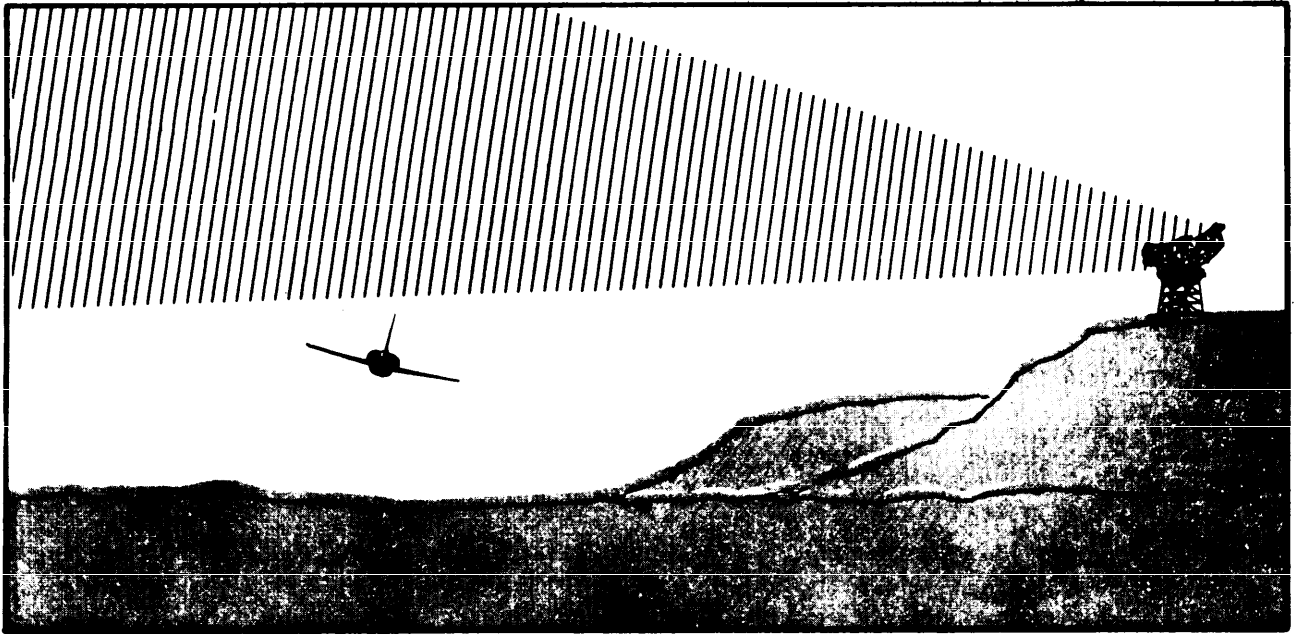

Figure 4-31. Low Level Evasion.

arrive at a lead angle or intercept points because of the constantly changing problem (figure 4-32).

Other tactics can also help degrade the air defense network. Diversionary raids roll back, and

crisscross tracks seriously hamper the defender's ability to track and engage hostile aircraft (figure 4-33). "Diversionary raids" are flights (by aircraft or drones) routed to areas away from the intended

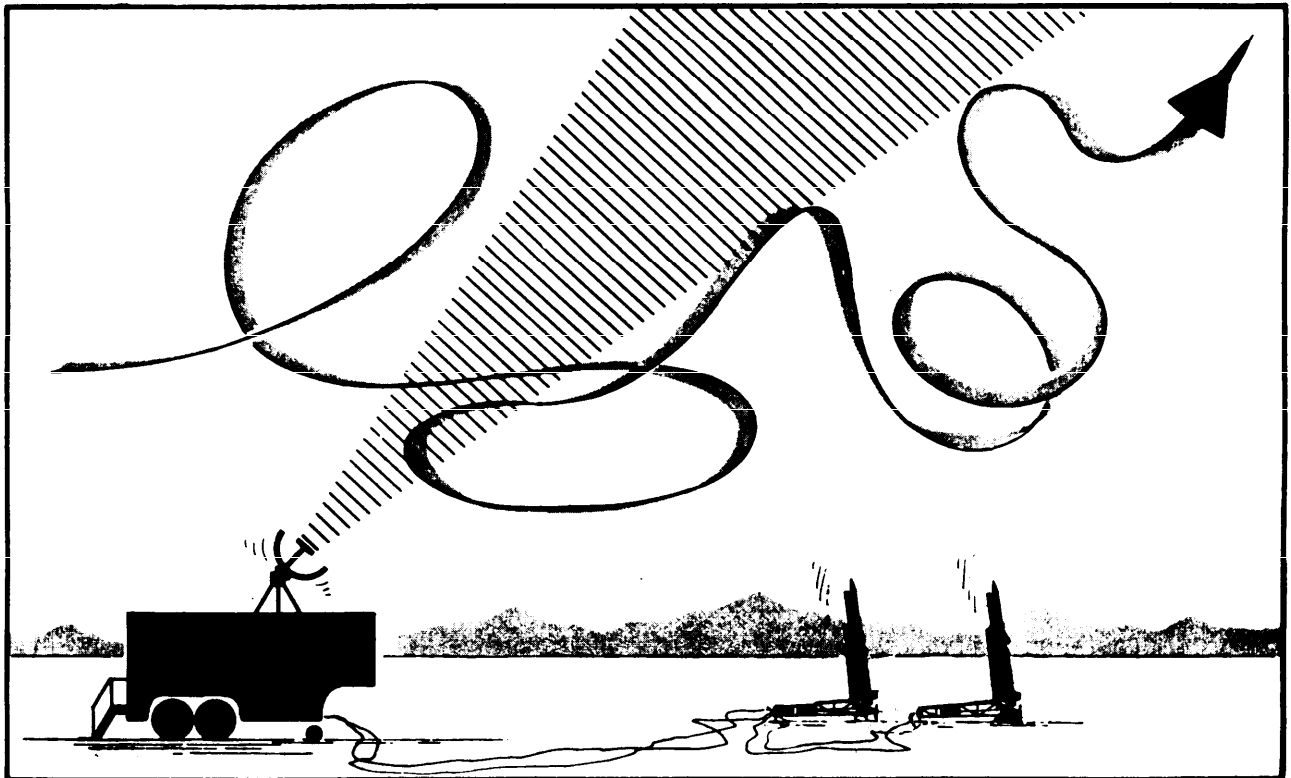

Figure 4-32. Evasive Maneuvers.

target. The enemy must assume that all targets on its radar are hostile targets. This results in diluting the enemy's defensive capabilities. "Roll back" is achieved when the penetrator force attacks targets sequentially from the periphery to the interior of the country. This allows the attacking force to strike targets without flying over great distances through concentrated defenses. Strike routes are planned to reflect continually changing paths and altitudes. This results in the entire force randomly "crisscrossing tracks" which cause confusion and loss of time, accuracy, and efficiency within the defense system.

Self-Protection

Another basic EW concept is self-protection of strike force aircraft. This may be defined as the ability of the striking aircraft to assure (in terms of EW) its own safe return from a mission through a hostile environment. EW devices designed to aid the self-protection effort include RWRs, jammers (internal, or in pods mounted externally on the aircraft itself), and expendables. The integrated and careful employment of these devices greatly enhances the probability of an aircraft successfully and safely completing a mission. RWRs are

devices which warn crewmembers of imminent or potential threat situations by detecting radars associated with terminal threats and acquisition radars. Jammers carried by the aircraft, whether designed to be an integral internal aircraft system or an external pod, can be employed by presetting them to known threat radar and communication frequencies and activating them as needed in the hostile environment. Pods have proven to be particularly effective "survivability increasing" devices. They are valuable because many fighter and fighter-bomber aircraft can carry them without extensive modifications, and their frequency coverage can be altered merely by switching component modules or reprogramming them. Expendables, as discussed earlier, can be employed to break the lock of tracking radars and IR missiles and thereby reduce the probability that any given aircraft will sustain damage or loss from a hit.

Support ECM

To further reduce attrition of penetrating aircraft, self-protection may be supplemented by ECM designed to support the strike force. This support may be provided in a number of ways, two of which are jamming and chaff.

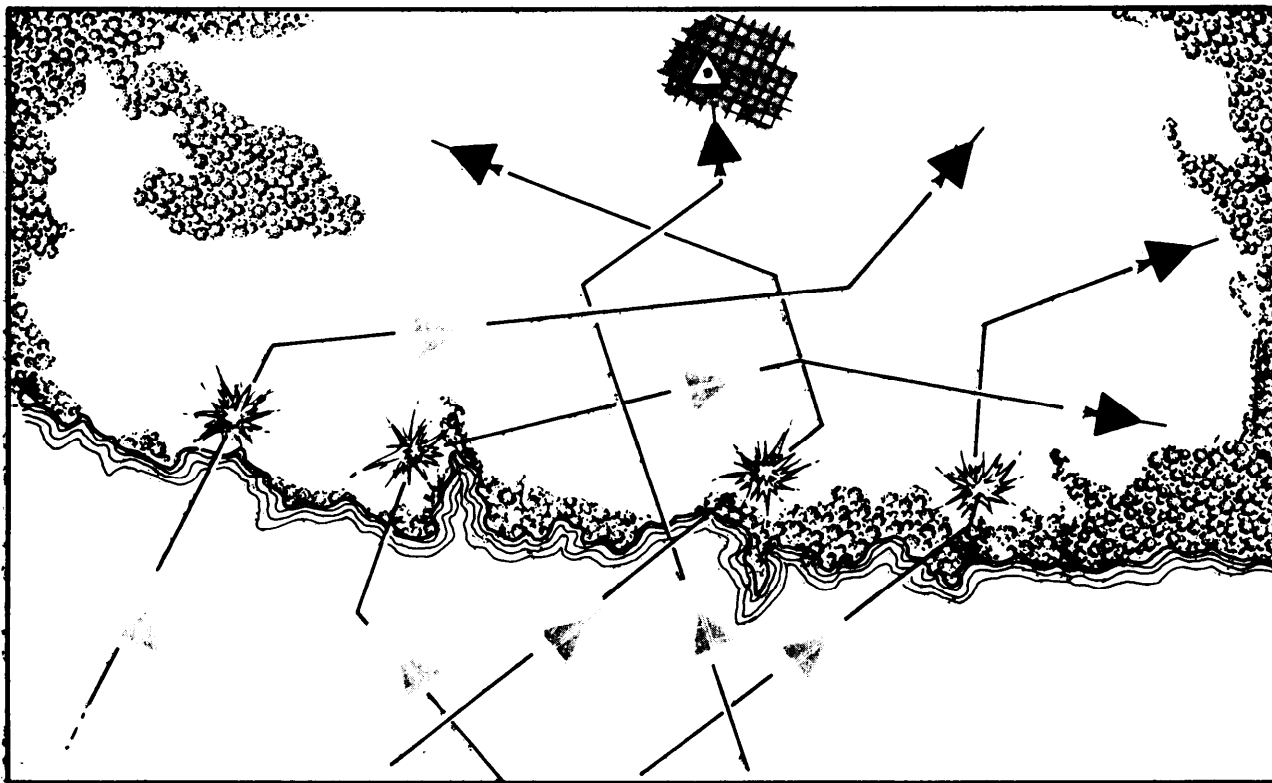

Figure 4-33. Crosstracking, Roll-Back, and Diversionary Raids.

Support jamming may be provided by "stand-off" jamming aircraft which remain outside the burn-through range of the terminal threat radars. Basically a side lobe jamming technique, stand-off jamming, masks the presence and (or) location of the actual strike force by saturating the ground radar with noise. Jamming may also be provided by "escort" aircraft which penetrate the terminal threat area with the strike force. These ECM aircraft may be specifically designed for the escort role or may be fighters fitted with pods to provide ECM and firepower protection. Support ECM may be further enhanced by ground and airborne communications jamming of the enemy command and control nets.

Chaff may be used with (or even in place of) jamming to add to the enemy radar operator's detection problem. Chaff may be dropped in a constant stream, as mentioned previously, to form a corridor in which penetrating aircraft may "hide" en route to their target. Clouds of chaff may also be created in order to mask an entire area above a specific target. These clouds obscure individual aircraft positions and deny the enemy the ability to accurately direct missiles and (or) AAA at the striking aircraft. When used together, jamming and chaff are effective ECM tools.

Strategic Versus Tactical Employment

The strategic employment of ECM is directed primarily to the protection of the manned bomber and associated weapons. This involves the use of ECM not only to counter early warning, height finder, AI, and terminal threat radars, but also to counter the associated ADC and control communication networks. As an integral part of the aircraft design, more emphasis is placed on the early warning and AI radar frequency ranges in the strategic environment than the tactical, since the bomber's long-range exposure, nonavailability of ECM support assets, and lesser maneuverability render it more susceptible to attacks.

Tactical ECM, on the other hand, is more concerned with terminal threat systems. This is because tactical aircraft (fighters and fighter-bombers) have shorter penetration profiles and can attack a target before many defensive systems, such as AIs, can respond. Because of the small size and limited payload of tactical aircraft, external jammers are frequently employed to counter specific terminal threat radars. Both strategic and tactical weapons systems employ ECM devices and will continue to do so as enemy threat capabilities increase.

SUMMARY OF ECM

In tactical and strategic conflicts, a combination of various ECM techniques significantly disrupts the defense network. Jamming, chaff, and decoys (when directed against the aircraft control and warning net) degrade the enemy's ability to detect, identify, and track a target. When jamming is introduced into the ground-to-ground and ground-to-air communications link, the command control system is disrupted. In short, the probability of successful completion of an assigned mission is greatly increased when ECM is properly employed.

ELECTRONIC COUNTER-COUNTERMEASURES (ECCM)

Aircrews on a military mission want to penetrate the defenses, reach the target, deliver weapons, and return to a friendly area after their strike. Two ways of doing this are to avoid detection or destroy the defense net. As a practical matter, avoiding detection is rarely possible for any appreciable period of time while destroying the radar net is limited by the sheer number and dispersal of the radar sites. Therefore, other measures are necessary for a successful penetration.

"Low Observables"

Despite modern countermeasures, newer radars are becoming increasingly difficult to defeat with ECM alone. The next logical step in our electronic chess game is to reduce the ability of radars to "see" aircraft even under the best of conditions. We do this by reducing our aircraft's radar reflectivity or radar cross-section (RCS). This concept has achieved a good bit of notoriety in the press under the title of "Low Observables" or "Stealth." Although the details of our efforts in this area are closely guarded, the basics are fairly simple. Flat portions of an aircraft's skin greater than one-half of a radar's wavelength will reflect an echo perpendicular to its surface when illuminated with radar energy. If the surface is curved, this "resonance effect" is decreased and the resulting reflection will be scattered in other directions. A cylindrical or ellipsoid-shaped aircraft (curvature in two dimensions) will yield very small radar echoes. Additionally, doubly curved surfaces are aerodynamically efficient. To create "Low Observables," we first design our

aircraft to avoid large flat surfaces or corner reflecting areas. This minimizes the amount of energy reflected back to the radar. An ideal shape would be a flying wing. Its delta shape would integrate fuselage, cockpit, and wings into a single flying wedge. Engines will be inside the body, not hung out as large radar targets.

A second step in reducing radar reflectivity is coating the outside of aircraft with special materials that will either absorb or deflect radar energy. Because of the price and weight of these materials, they are only placed on parts of the aircraft with large radar cross-sections. Many new composites are being developed that are stronger and lighter than steel or titanium yet do not reflect radar energy. Another development is radar absorbent material (RAM). One type of RAM is based on destructive interference. A material permeable to radar energy is applied to the aircraft in two layers. As a radar's energy passes in through the first layer, it is reflected back out by the second layer. The reflection is out of phase with incoming energy, and the two signals cancel each other out by destructive interference.

The combination of a minimally reflective aircraft surface selectively coated with these new materials results in an aircraft difficult to paint on radar. Combined with proper tactics and countermeasures, even the most modern radars will have great difficulty dealing with future "Low Observable" aircraft.

An air defense net is built to deny an attacking force the opportunity to reach its targets. The defense net attempts to detect the attacking force as early as possible. If the attacking force is flying at an optimum airspeed and altitude and is employing no ECM, the defense radar net usually can detect the attacking force early enough to permit a timely selection of weapons.

However, the attacking force will normally be using ECM against the defense net. The defense net now has the problem of detecting and tracking the attacker despite the jamming. To do this, the defensive net radar operators will employ ECCM.

ECCM, as applied to air defense operations, is that division of EW involving actions taken by the defensive net to attempt to retain use of its EM equipment despite the attacking force's use of EW. Many types of ECCM can be used to reduce the effects of ECM. This section discusses several methods used by the defensive net to overcome the penetrating aircraft's ECM.

Although the primary emphasis of this section is on equipment which can reduce the effect of ECM, it should be noted that an effective ECCM

program requires more than merely modifying equipment. Planning and training are of equal, if not greater, importance.

Planning includes several aspects. As an example, the operating frequencies of the defensive radar network should present as great a problem as possible to the invading aircraft. Additionally, redundant control systems should be maintained.

The most critical elements in an ECCM program are the operators. They must know how and when to use the different ECCM features of their equipment and realize the impact various ECCM features have on the radar's performance. Training in an ECM environment ensures that operators effectively use their equipment.

Fixes

Fixes is the term used to describe features designed into a radar system or modifications to existing systems which degrade or eliminate the effectiveness of ECM.

Common Transmitter Fixes

Certain characteristics of air defense radar transmitter outputs can be changed to enhance target detection and tracking despite ECM.

Frequency Agility. If the penetrating force is jamming a radar, one ECCM technique is to change the radar's operating frequency. The ability of a radar set to be tuned rapidly from one frequency to another frequency is called "frequency agility."

Tuning can be done in a number of ways. It can be done manually, or a programmed frequency change can be built into the radar set. The programmed frequency changes can be made automatically, at predetermined times, or at random intervals. A radar might be designed to operate on a "least jammed" frequency; that is, a special receiver searches the operating band of the radar set and tunes the transmitter to a frequency where there is little or no jamming. However, in a dynamic EW environment, the least jammed frequency may not remain that way for very long. Thus, in this contest between radar and jammer, the faster the frequency change can be made and the wider the band in which changes are possible, the more effective this technique becomes.

Frequency agility is most successful against a manually tuned spot jammer. However, because

barrage jammers are not able to maintain a constant power out at each frequency within its bandwidth, frequency agility enables the defensive system to exploit the frequencies at which the jamming is least effective. Its capability against a sequential spot jammer is entirely dependent upon the relative retuning rates of the radar and the jammer. One primary benefit of a frequency agile radar is that it normally compels a jammer to use less efficient sweep or barrage jamming modes.

Diplexing. Diplexing is the use of two separate transmitter and (or) receivers operating on different frequencies, but using a common antenna system. Different diplexing techniques depend on the radar's circuitry, whether or not two receiver systems are available, and the type and mode of the jamming encountered. Diplexing forces the attacking (aircraft) to divide its power between both transmitted signals or to determine which signal represents the most significant threat to it. No single radar has available all of the video processing options possible with diplexing. Selecting the best option depends on the number and type of the jamming signals, the nature and effectiveness of the jamming received, the relative amount of power received on each frequency, and the antijamming operator's objective in employing the fix (reduce data, detect, and track a particular target or targets regardless of overall effect on the radar, etc.).

Power Add. If the radar has two (diplexed) transmitters, as are required for diplexing, it may be possible to transmit the same frequency simultaneously on both transmitters. When this is done, output power is significantly increased, and there is a proportionate increase in the strength of the echo at the radar received input. This technique improves the S/J ratio and extends the burn-through (detection) range. When increased power is used in communication systems, it reduces the system's susceptibility to ECM by increasing the S/N ratio.

Increased PW. The effect of PW on a radar's ability to detect a target has already been discussed in chapter 2. Increasing a radar's PW increases the average power, allowing more power to hit its target and resulting in an increase in echo strength at the receiver input. Chapter 2 also mentioned that increasing the PW to attain a higher average power is done at the expense of range resolution. Range resolution decreases with increased PW.

Pulse Compression. Pulse compression increases average transmitted power (without an increase of peak transmitted power) with no loss of range resolution. In a pulse compression radar, a short pulse is generated and stretched during transmission time. Then, when it returns as an echo, the pulse is restored to its original width.

The process of stretching the pulse is called coding. There are several ways of coding the transmitted pulse. Assume a radar uses a 1 μ sec pulse which is stretched to 5 μ sec (5:1 compression ratio). For all practical purposes, the radar is transmitting five 1- μ sec pulses without stopping. The returned 5- μ sec echo is broken down to five 1- μ sec pulses several times as large as the original echo. If a penetrating aircraft is jamming the radar, the amplitude of the echo signal from the aircraft is multiplied by the compression ratio, whereas, the jamming signal is not. If the ECM operator on the penetrating aircraft has determined the transmitted PW, the operator might develop a similar pulse and transmit it back to jam the radar. The penetrating aircraft cannot tell that the defense net radar pulse has been stretched (before it's transmission). To be effective, the jamming pulse would have to contain the characteristics of the radar pulse before it's stretching.

Pulse compression is effective against many types of ECM because it enhances the radar echo of the target but does not enhance the jamming (unless the jamming is properly coded).

Staggered PRF. One type of deception jamming is synchronous pulse jamming. This type of jammer "locks on" to the defensive radar's pulse. Every time the jammer's receiver senses a pulse from the defensive radar, it sends back a series of pulses at regular intervals, filling the defensive radar's PRT or listening time.

If the jammer is continuously pulsed and has sufficient power, some of the defensive radar's side and back lobes may also be jammed. The radar operator will then see several spokes consisting of a series of targets on the scope. When the jammer is very close to the radar's location, the radar operator may even see a series of concentric circles. These phenomena are not frequently observed, however, because the effectiveness of pulsed jammers results from their ability to match the victim radar's pulse characteristics rather than the high power which is necessary to effect the radar's side and back lobes.

One ECCM fix for synchronous pulsed jammers is to stagger the radar's PRF (figure 4-34). Normally, the interval between transmitted pulses

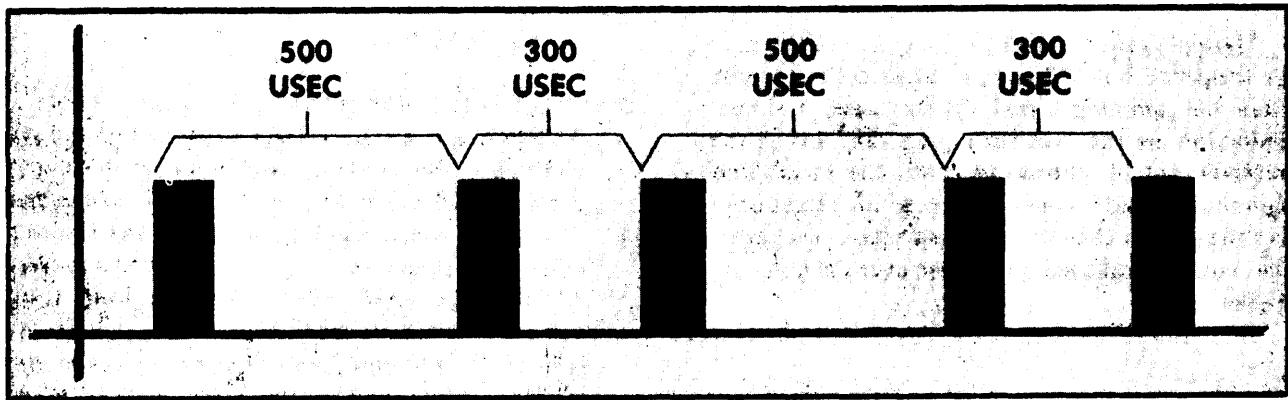

Figure 4-34. Pulsed Radar With Two-Position PRF Stagger.

(PRI) will not change from pulse to pulse. When this interval is staggered, the synchronous false targets generated behind the aircraft maintain their relative distance from the target aircraft and thus appear at the same spot on the scope for each transmitted pulse. However, the false targets that appear in front of the target aircraft do change their relative distance from the transmitted pulse because the time between transmitted pulses can vary on a pulse-to-pulse basis. This could enable video integration techniques to distinguish the false jamming signals from the target's actual radar echo.

Jittered PRF. Jittered PRF is similar to staggered PRF but works differently since the PRF varies randomly from pulse to pulse (figure 4-35). This "fix," like staggered PRF, is used to combat synchronous pulse jamming. The biggest disadvantage of jittered PRF is that it cannot be used in conjunction with moving target indicator (MTI), a special receiver which eliminates ground

clutter and stationary targets from the radar's video output.

Common Receiver Fixes

A receiver's function is to amplify a received signal and then present it in some manner. In a radar set, this means the target echo must be stronger than atmospheric noise or a jamming signal (figure 4-36). This is known as the S/N or S/J ratio. If the target echo's amplitude exceeds that of a jamming signal, receiver gain reduction may eliminate the jamming while retaining the target. Gain reduction affects both target and jamming equally. If the target echo's amplitude is less than or equal to that of the jamming, reducing the receiver gain will result in loss of the target at the same time or even before losing the jamming signal. Other design features allow the receiver to resolve target identification. When a target echo is stronger than the jamming signal, one of the following gain control techniques may be employed:

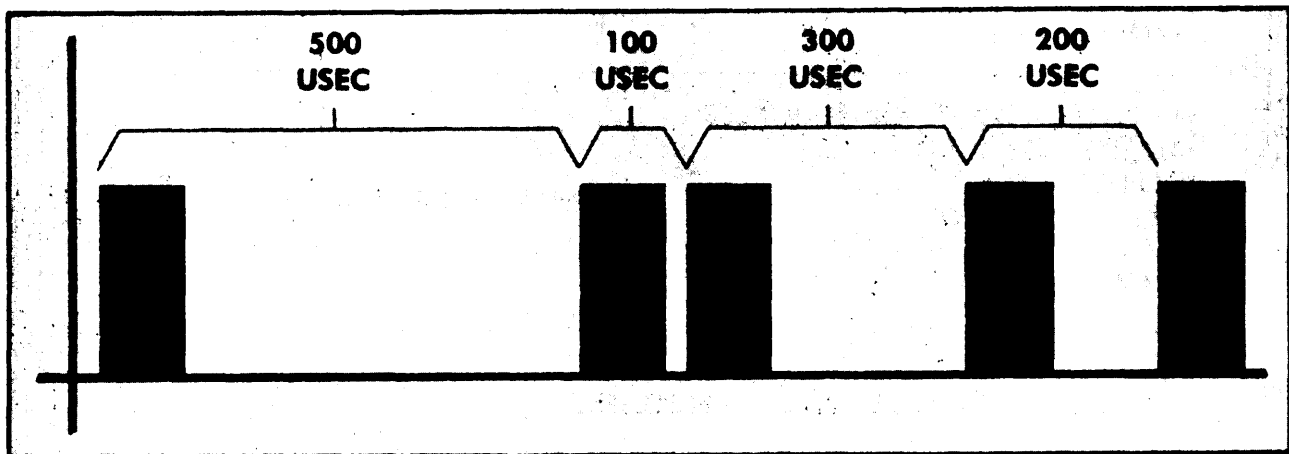

Figure 4-35. Pulsed Radar With Jittered PRF.

Manual Gain Control (MGC). A receiver may be saturated but still have a target echo stronger than the jamming signal. In this case, a simple reduction in the receiver's gain may bring the receiver out of saturation. Both the target and jamming are attenuated equally so the target echo is still stronger than the jamming signal. The target can now be displayed on a scope over the jamming signal.

Instantaneous Automatic Gain Control (IAGC). IAGC and other automatic gain control (AGC) function in the same manner. The AGC circuit samples the average noise level at the output of the receiver and, by raising or lowering the intermediate frequency (IF) gain of the receiver, maintains a constant output. Most AGC circuits operate too slowly in an ECM environment. The normal response time of an IAGC circuit is several microseconds. In a noise or CW jamming environment, IAGC can be used to reduce the possibility of receiver saturation. Better choices for operation in a noise jamming environment are the log or Dicke Fox receivers, which

are discussed later.

Automatic Video Noise Leveling (AVNL). AVNL is an AAGC system used to maintain a constant noise level at the output of the video amplifiers of a radar receiver. AVNL varies the gain of the video amplifier stages of the receiver when the noise level increases or decreases. AVNL, like AGC, is a relatively long time constant circuit. It takes several milliseconds to respond fully to input level changes. Normally, the AVNL circuit samples the noise level at some small range interval near the maximum range of the radar and uses this level to determine the required gain setting.

Moving Target Indicator (MTI). In a radar, it is often desirable to eliminate stationary targets and display only moving targets. One way to accomplish this in a pulsed radar is to display only those targets that have a measurable Doppler shift. This technique is known as MTI. MTI refers to a radar in which the Doppler frequency (velocity) measurement is ambiguous, but the range measurement is unambiguous.

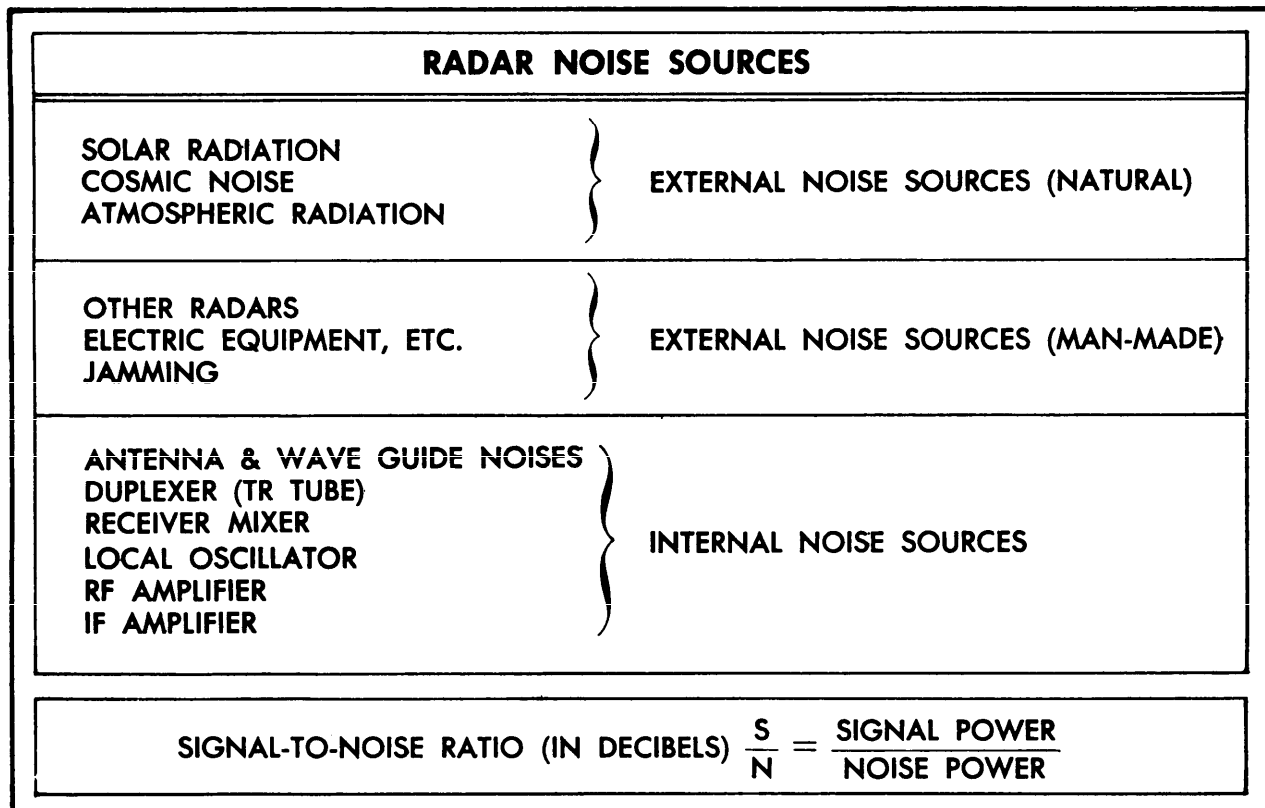

Figure 4-36. Sources of Radar Noise.

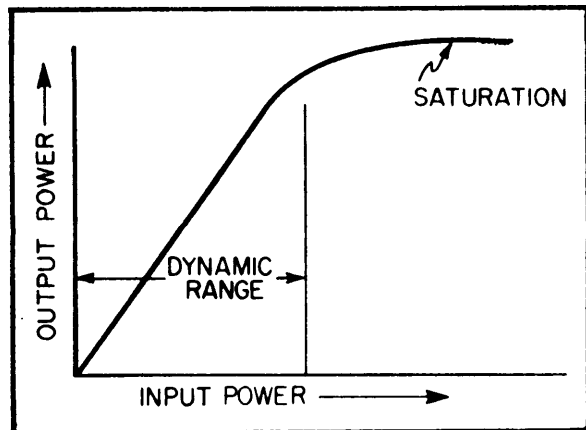

Figure 4-37. Linear Receiver.

Fast Time Constant. The FTC technique is used in a strong clutter or jamming environment to improve target detection. A typical FTC circuit uses a time constant that is a little longer (perhaps 50 percent longer) than the transmitted radar pulse. A normal target return passes through the circuit with little or no distortion, whereas, a longer pulse return, such as those from clutter or long pulse jamming, is reduced in length.

For proper FTC action, the receiver must not become saturated in the presence of strong clutter or jamming signals. If saturation takes place in the IF or video stages before the FTC circuit, target data cannot be recovered by FTC action. An IAGC circuit might be used to prevent saturation, thereby, permitting FTC to function properly; but if target data is once lost, it cannot be recovered by FTC action. A log or lin-log receiver is the most desirable type of receiver to use with FTC.

Types of ECCM Receivers

Linear (Lin) Receiver. The primary receiver on many radar sets is a linear (lin) receiver. A linear receiver is like a radio receiver. That is, a signal is amplified by successive stages of the receiver (figure 4-37).

A strong jamming signal can easily cause saturation in a linear receiver, and while saturation exists, all target information is lost.

Short, high amplitude signals can also interfere with the processing of target data by causing "ringing" of the tuned circuits in the receiver. High-powered, narrow-pulse jamming and fast sweep jamming are examples of short, high amplitude signals. Ringing is the continued oscillation of the tuned circuits after these high

amplitude signals have ended.

A MIT receiver is a modified linear receiver and suffers from the same limitations as other linear receivers: noise, saturation, and ringing. The ECCM receivers discussed below minimize these detrimental effects.

Logarithmic (Log) Receiver. The log receiver has a logarithmic response to input signals. As the input signal level increases, the gain of the receiver decreases. Small signals, such as the radar return from an airplane, receive high amplification and large signals, such as jamming signals, receive low amplification. The signal-handling capability or dynamic range of the log receiver is greater than that of the lin (linear) or lin-log receivers (figure 4-38).

Lin-Log Receiver. This receiver combines the advantages of the lin and the log receivers. The operation is linear for weak signals up to a certain input signal level called the crossover point. Signals above this level receive logarithmic amplification. Thus, weak signals receive maximum amplification and large signals receive low amplification. The dynamic range of the lin-log receiver exceeds that of the linear receiver.

Logarithmic and lin-log receivers prevent receiver saturation except in the presence of extremely high-powered jamming.

Dicke-Fix Receiver. For ringing and noise, it is necessary to process the IF in a different manner than by controlling the gain. This is done with a Dicke-Fix receiver.

The Dicke-Fix receiver contains a wideband amplifier, a limiter, and a narrowband amplifier. The interfering signal (jamming) is amplified, with the target return, in the wideband amplifier. This

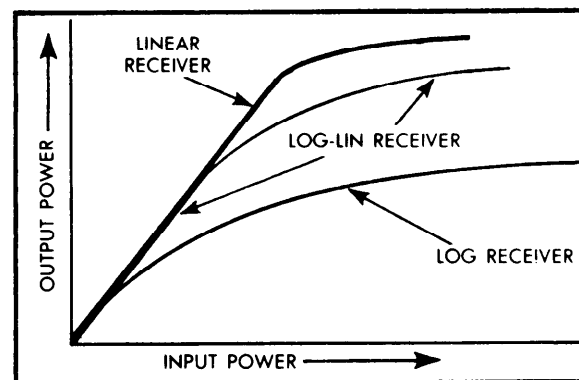

Figure 4-38. Comparison of Receiver Responses.

amplifier is designed to reduce the effects of ringing. Once the signals are amplified, they are limited; that is, the noise and target returns are held below a set amplitude. After the signals are amplified and limited, they are fed to a narrow-band amplifier. This amplifier is tuned to the center frequency of the return pulse. Random noise frequencies thus receive less amplification in the narrowband amplifier than the desired frequencies.

The Dicke-Fix receiver is used to reduce the effects of fast swept noise and narrow pulse jamming.

Additional Fixes

Side Lobe Cancellation (SLC). SLC is a technique that minimizes the effects of antenna side lobe pickup. All directional antennas have side lobes of various strengths. The higher gain normally found in a radar's side lobes is between 15 and 30 decibels (dB) below the main lobe gain. Consequently, a jammer of moderate power will introduce jamming through some of the side lobes as well as the main lobe. Further, if a heavy jamming environment is assumed, a situation may arise where jamming is introduced into the radar

receiver throughout 360 degrees. The radar set cannot discriminate between energy being picked up by the side lobes from energy picked up by the main lobe. Thus, any energy entering a radar's side lobe is displayed on a scope at the azimuth indicated by the main lobe. Side lobe pickup can confuse the radar operator by: (1) making it difficult, if not impossible, to locate the jammer at its correct azimuth, and (2) permitting the jammer to screen targets at other azimuths (figure 4-39).

A side lobe cancellation system uses a separate omnidirectional antenna and receiving system with the main radar antenna and receiving system. As the term "side lobe cancellation" implies, unwanted signal returns are eliminated by a cancellation technique. The cancellation can be done at the IF or the video level.

In practice, the gain of the combined SLC omnidirectional antenna plus its receiver is adjusted to be slightly greater than the gain of the combined main antenna's highest side lobe plus the main radar receiver (figure 4-40). If a side lobe receives a signal, the omnidirectional antenna also detects the same signal, but at a greater relative strength. The resultant cancellation yields a negative signal which is not displayed. The main

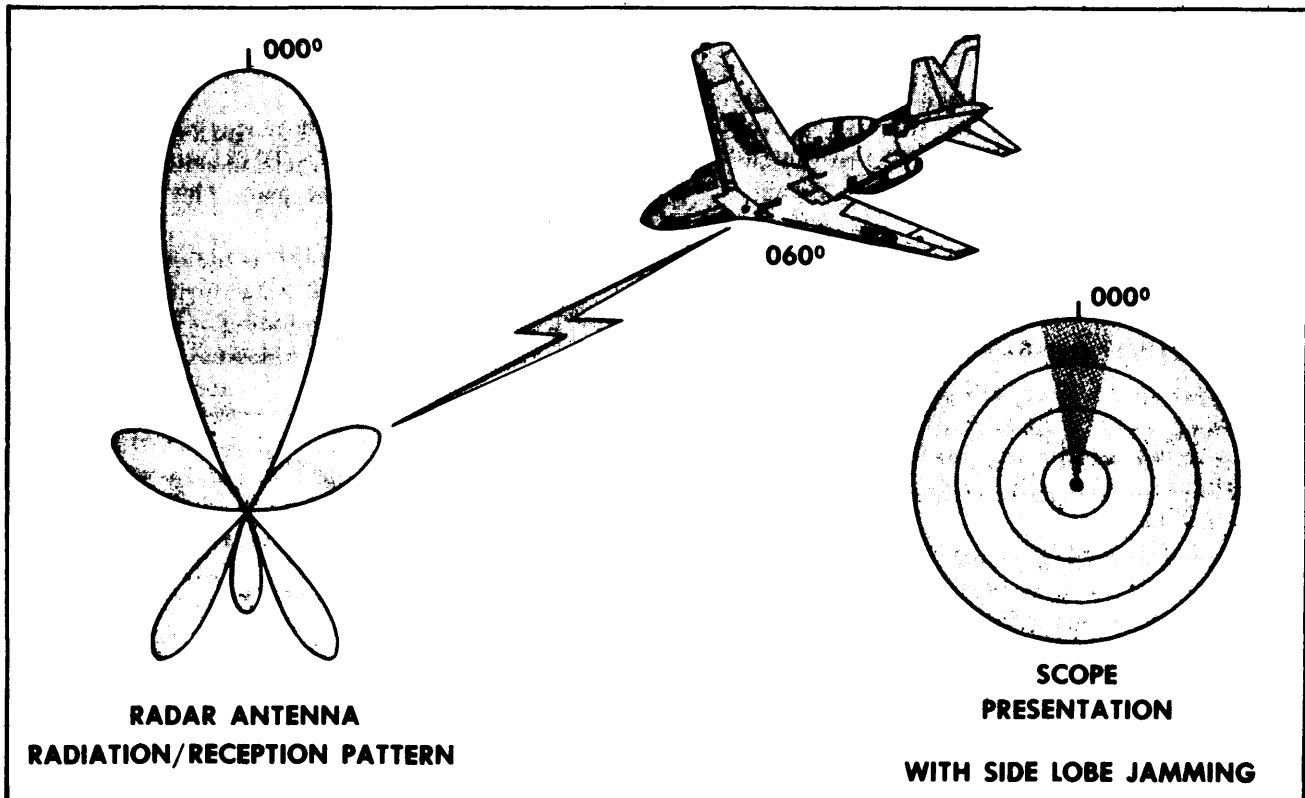

Figure 4-39. Side Lobe Jamming.

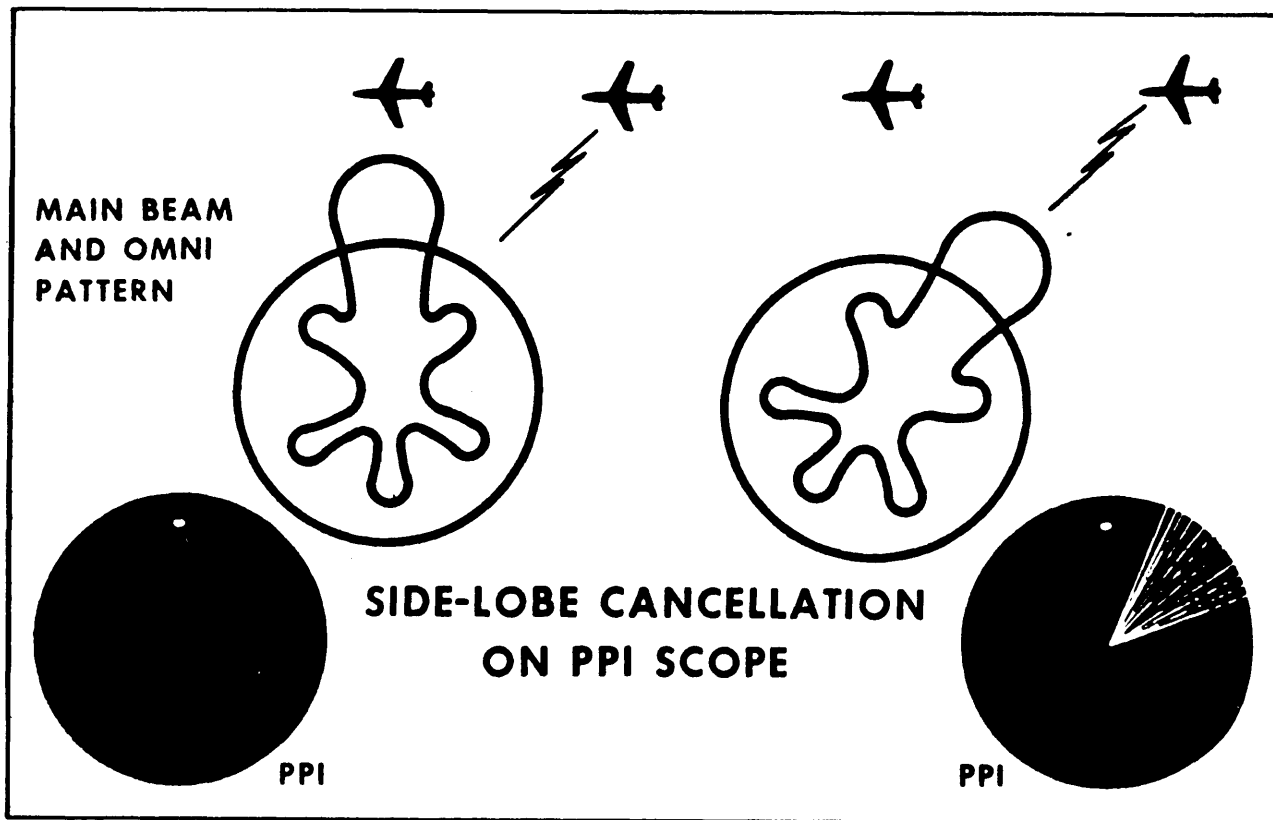

Figure 4-40. SLC Block Antenna Patterns.

beam still receives signals at a higher gain than the omnidirectional antenna, so these targets and jamming from the azimuth of the main beam are still displayed. But SLC can eliminate side lobe jamming while possibly retaining targets picked up by the main lobe (figure 4-41).

Side Lobe Blanking (SLB). SLB employs the same basic principles as SLC, with the exception that SLB eliminates unwanted side lobe returns by a blanking technique rather than the cancellation method of SLC. When the blanker output indicates side lobe jamming, a blanking is generated that turns off the main receiver. While the main receiver is blanked, there can be no output of any kind. Thus SLB will cause the loss of valid targets. If the jamming is of short duration, such as pulse jamming, SLB may still be effective because it blanks the main receiver only for short time intervals, thus minimizing the loss of valid target data to the SLB.

Pulse Width Discrimination (PWD). PWD is a technique used to discriminate against received pulses that do not have the same duration as the radar transmitted pulse. Some PWD circuits discriminate against all pulses that are either

shorter or longer than the transmitted pulse duration, whereas, other PWD circuits discriminate only against pulses that are longer than the transmitted pulse.

PWD processes every radar signal via two paths. One is the normal signal path through the receiver. The other consists of circuits that measure the duration of each signal pulse and generate control signals to suppress those of incorrect length.

PWD is used in eliminating the effects of pulse-type interference when the interference pulses are not the same length as the real radar pulses. Since this circuit generates a blanking gate which shuts off the receiver when a pulse of improper length is sensed, loss of valid target data can result.

Detected Pulse Interference (DPI). DPI is a technique similar in some respects to PWD, since signals being received are processed through two paths. One path carries the received radar signal while the other path develops a control signal to suppress or blank the undesired signals. In the control signal generator, the signal is passed through two channels. One channel includes a delay equal to the radar's PRT; the other channel has no delay. The delayed and undelayed signals

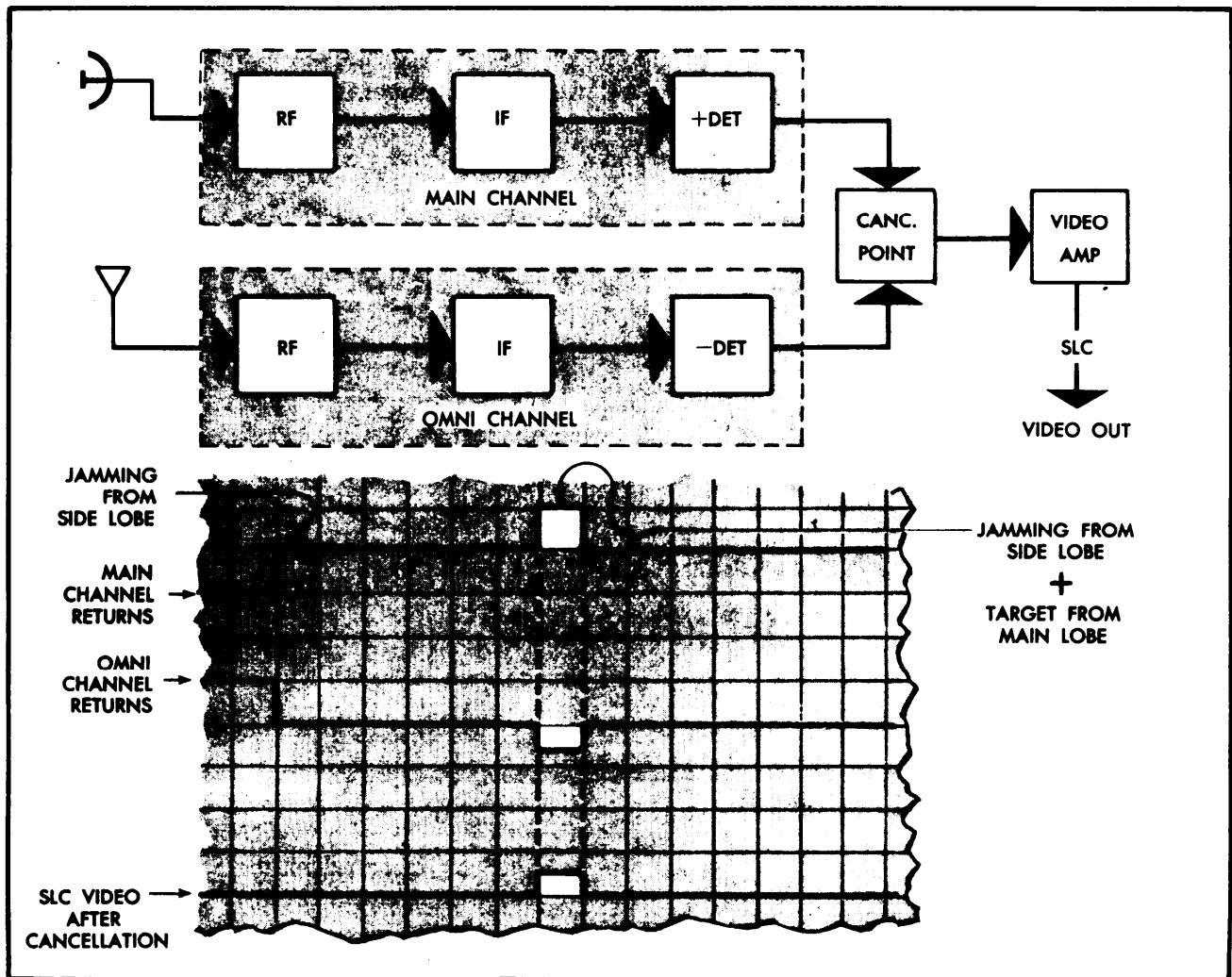

Figure 4-41. SLC Block Diagram and Waveforms.

are compared for coincidence. Real targets will have approximately the same range on successive returns, but nonsynchronous interference will not. If a pulse appears on one PRT but not on the next, it is blanked. If a target appears at the same range on successive PRTs, it is considered real and allowed to pass through. Returns that appear to move appreciably in range during each PRT are suppressed.

DPI is effective in eliminating the effects of nonsynchronous pulse jamming and interference from adjacent radars.

Nonsynchronous Pulse Suppression (NSPS).

NSPS is an ECCM fix designed to counter nonsynchronous pulse jamming and interference from adjacent radars. NSPS operates like a reverse MTI. It continuously compares radar video over successive range sweeps and blanks any

pulse that does not occur at approximately the same range from sweep to sweep.

SUMMARY OF ECCM

To overcome the effects of ECM by a penetrating aircraft, the air defense system employs ECCM. Most ECCM fixes are only effective against particular types of ECM, and the use of ECCM may degrade the ability of a radar by limiting its range or reducing its sensitivity. ECCM may or may not be effective in preventing effective ECM from degrading communications channels. System degradations can be exploited by penetrating forces to help them reach their target.

ECCM is not just a "fix" that is used by a ground radar operator to reduce the effectiveness of a penetrating aircraft's ECM. It is an important

EW "tool" used by those who wish to retain friendly use of the EM spectrum and may be active or passive. The effectiveness of ECCM in the "move-countermove" strategy of EW depends not only upon the equipment but also the training of the operators who use the equipment. Air (or ground) operators must know when EW is being employed against them and must respond accordingly to maintain control of the spectrum. Operators must be aware of hostile ESM/SIGINT capabilities when radiating EM energy in order not to highlight themselves as to their intentions or capabilities. In the past, this primarily involved tactics such as "running silent" or "emission control," but today ECCM is considered when EM equipment is designed and developed for our continued use and control of the EM spectrum. A good example of this is new secure voice and jam-resistant radios in an aircraft. The control of the entire spectrum comes into play here, not just radar or communications frequencies. Advances in technology in the millimeter wave (MMW) and EO portions of the EM spectrum have shown us that these too must be considered in our employment of EW. Design of future aircraft systems, as well as airfoil and engine design, will consider strongly the impact of EO, the next section of this chapter.

ELECTRO-OPTICS (EO)

Historically, EW has been primarily concerned with the RF portions of the EM spectrum. Although exploitation of the EO portion of the spectrum has been neglected in the past, both the US and foreign powers are now highly concerned with EO and its potential military applications.

EO is the broad field of science dealing with the use of the IR, visible, and ultraviolet (UV) portions of the EM spectrum. Like radar, EO deals with EM radiation, but at higher frequencies. EO applications parallel RF applications, such as search and acquisition systems, warning systems, communication systems, and missile guidance systems. Our eyes, sometimes aided by an optical device, such as binoculars, have been used for years to provide warning, target identification, and range data in the visible light spectrum. More recently, these frequencies have been used for television and night viewing. Exploitation of UV frequencies is limited because atmospheric ozone absorbs nearly all of the UV portion of the spectrum. However, the potential for IR use is tremendous.

The existence of IR has been known for over 100 years, and the investigation of this particular phenomenon has followed closely that of microwaves. Practical applications of IR radiation first attracted military interest during WW II. During this period, the US and Great Britain developed and employed IR equipment, such as the Snooper Scope and IR communications systems. However, the major Allied interest was radar development, and IR development lagged far behind. The Germans, however, attacked the IR problem with an aggressive development program. Their efforts during WW II produced the first IR homing missile, the Wasserfall; IR headlamps for night driving; and an IR communications system, the Lichtsprecher. Today, IR technology is receiving considerable attention by the DOD. EO technology is moving into such areas as weapons guidance and fusing, reconnaissance and intelligence collection, aircraft defense, fire control, communications, and missile warning systems.

PRINCIPLES OF IR RADIATION

The frequency of IR radiation extends from approximately 300 thousand to 400 million megahertz. In the frequency spectrum, IR falls between the upper limit of microwaves and the lower limit of visible light. In dealing with radar, frequencies were identified by cycles per second or hertz, but because of the high frequencies of IR radiation, it is more convenient to use wavelength to identify the IR portion of the EM spectrum. This permits use of small numbers. The wavelength of the highest frequency IR is 0.72×10^6 meters. A unit of measurement called the micron (μ) is used (a micron being one-millionth (10^6) of a meter). IR falls in the EM spectrum between wavelengths of 1,000 and 0.72 microns, while visible light occupies the region from 0.72 to 0.39 microns (figure 4-42).

Because of its location in the frequency spectrum, IR radiation exhibits some of the characteristics of microwaves and some of the characteristics of visible light. Like radar energy, IR can be transmitted through materials opaque to visible light. Like visible light, it can be optically focused by lenses and mirrors.

Warm objects emit IR radiation, and the temperature of the object dictates the characteristics of the radiation. As the temperature of the materials increases, the overall bandwidth of the radiation and the radiant "intensity" increases. Also, as the temperature increases, the peak

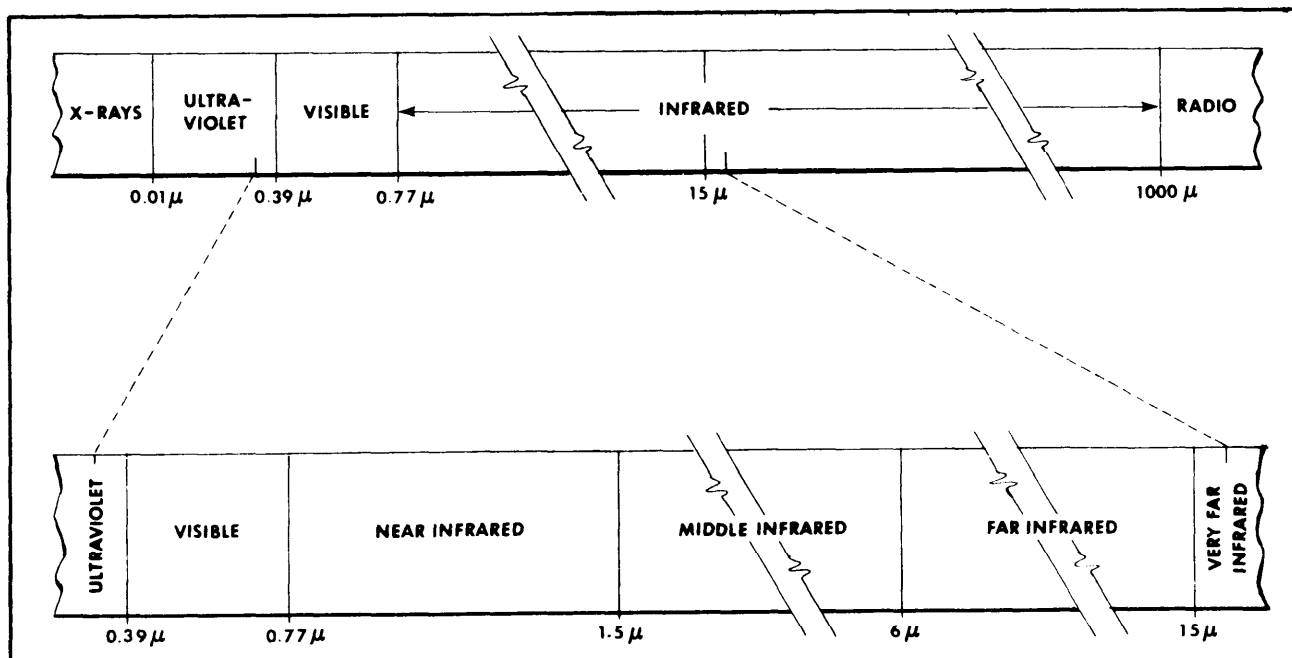

Figure 4-42. The Optical Spectrum.

energy intensity shifts to shorter and shorter wavelengths. The object's efficiency as an energy emitter is called its emissivity. All real objects have an emissivity less than 1, and it depends mostly on its surface finish.

Attenuation of IR Radiation

As with all EM radiation, optical radiation intensity diminishes inversely as the square of the distance between the source and the receiver. In addition, the atmosphere further reduces the amount of radiation that reaches the receiver because all wavelengths are not transmitted through the atmosphere with equal efficiency. As the energy travels through the atmosphere, certain frequencies are absorbed or scattered.

Water vapor in the atmosphere is the greatest attenuator of IR radiation and varies as the weather conditions vary, with negligible absorption at altitudes above 30,000 feet. Next in importance as an attenuator is carbon dioxide (CO_2). The percentage of CO_2 in the atmosphere does not depend on the weather; it is practically constant up to a height of about 30 miles. Carbon dioxide absorption is predictable and occurs only in the IR region.

Another form of radiation attenuation is scattering, which is caused by dust particles and water droplets in the atmosphere. This type of attenuation is also largely dependent on weather conditions and cannot be predicted. Most of the

scattering occurs at lower altitudes and at the shorter wavelengths. Other atmospheric elements cause little or no attenuation of IR energy. Figure 4-43 illustrates atmospheric transmission at sea level. The wavelengths of high transmission are called windows.

IR DATA CHART

Figure 4-44 is a tabulation of data on the IR spectrum, IR sources, and materials for IR equipment.

The chart is constructed on a logarithmic scale of the wavelength for the IR spectrum and is divided into the near, intermediate, far, and very far IR regions. The first major block down illustrates the relation of temperature to the wavelength at which peak radiation occurs. Shaded sections on the chart indicate where the wavelengths of peak radiation may occur. The peak wavelength of IR energy from the plume of a rocket falls to the left of the scale at $3,500^{\circ}$ to $4,000^{\circ}$ K. The next block down shows the bands of atmospheric attenuation according to IR wavelength shown at top of chart. This scale identifies the windows of little or no attenuation through which the energy may be transmitted for great distances. It emphasizes the important wavelengths on which search, track, and homing systems operate most successfully. The third block

lists materials available for detectors and the wavelengths to which they will respond. The fourth and last block lists materials and the wavelength at which they will pass or block IR energy. Such information is used to design systems for detecting specific wavelengths of IR energy.

LIGHT AMPLIFICATION BY STIMULATED EMISSION OF RADIATION (LASER)

A laser is a device that produces a very intense beam of light which contains radiation in a very narrow bandwidth. Lasers represent the fulfillment of a long-time technological goal—that of developing a light beam intense enough to burn through any material. Because the laser beam travels at the speed of light and has such awesome power, the potential for a “death ray” type weapon exists. Even so, lasers have many other military applications.

Laser Principles. Ordinary light contains literally billions of frequencies traveling in a random direction with arbitrary phase relationships and varied amplitudes. This composite complex is called incoherent radiation.

Laser light, on the other hand, is an intense, monochromatic, highly directional, and coherent beam. It is considered monochromatic because its frequency bandwidth is so narrow.

Figure 4-45 shows a basic laser's construction. The pumping process excites the laser material causing it to radiate photons of light at its natural spectral wavelength. These photons of light bounce back and forth between the mirrors,

passing repeatedly through the active laser material, causing further emissions with each pass. The optical waves quickly build up into a coherent and monochromatic laser oscillation at an optical frequency.

There are a variety of laser materials and pumping processes ranging from ruby crystals, which are optically pumped, to semiconductor diodes and certain gases which are electrically excited. Each laser substance emits one or more unique spectral lines (wavelengths). These emissions are coherent (all waves are in phase) and monochromatic (all waves are of the same wavelength). Because all the waves are coherent and monochromatic, there is no interference caused by the waves disturbing each other. The waves also travel in the same direction in a tight, collimated beam with little spreading. Since it does not spread and since its waves are in phase, the laser's light is very intense (high energy density) and does not diminish in brightness as it leaves the laser. The major cause of spreading is due to atmospheric dispersion.

Laser Applications. Perhaps the best known military use of lasers is as a laser designator (LD) for laser guided weapons. In this application, a laser beam is pointed at the target which then reflects the laser light. A laser seeker mounted on the nose of the bomb detects the reflected energy and sends error signals to guide the weapon to the laser-designated target. The great accuracy of this method enables a few strike aircraft to destroy a target which previously required many aircraft to ensure destruction.

A pulsed laser can be used as a radar and range

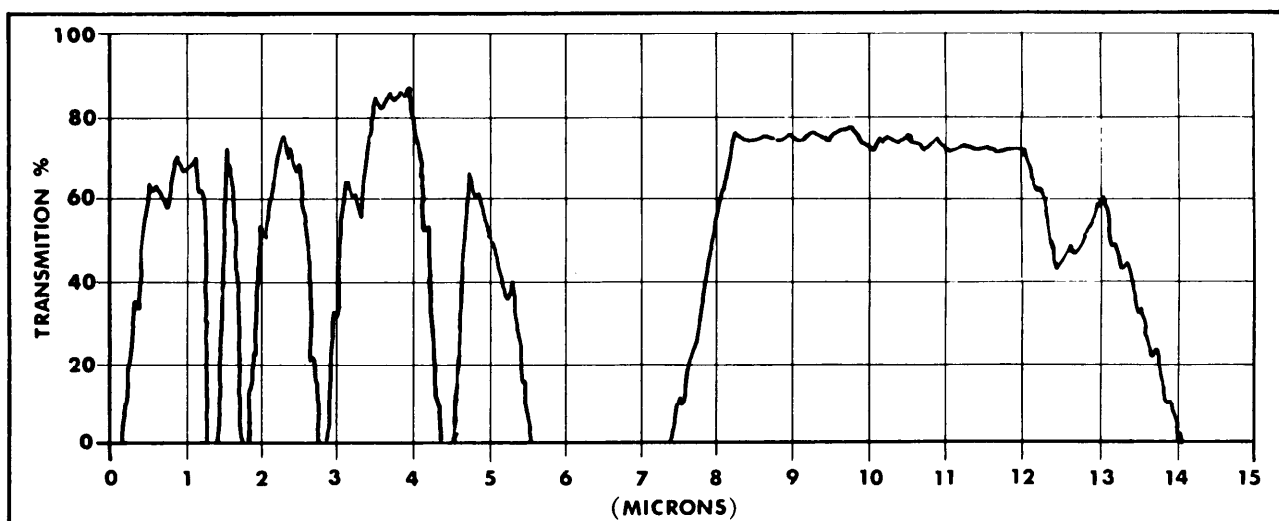

Figure 4-43. Atmospheric Transmission.

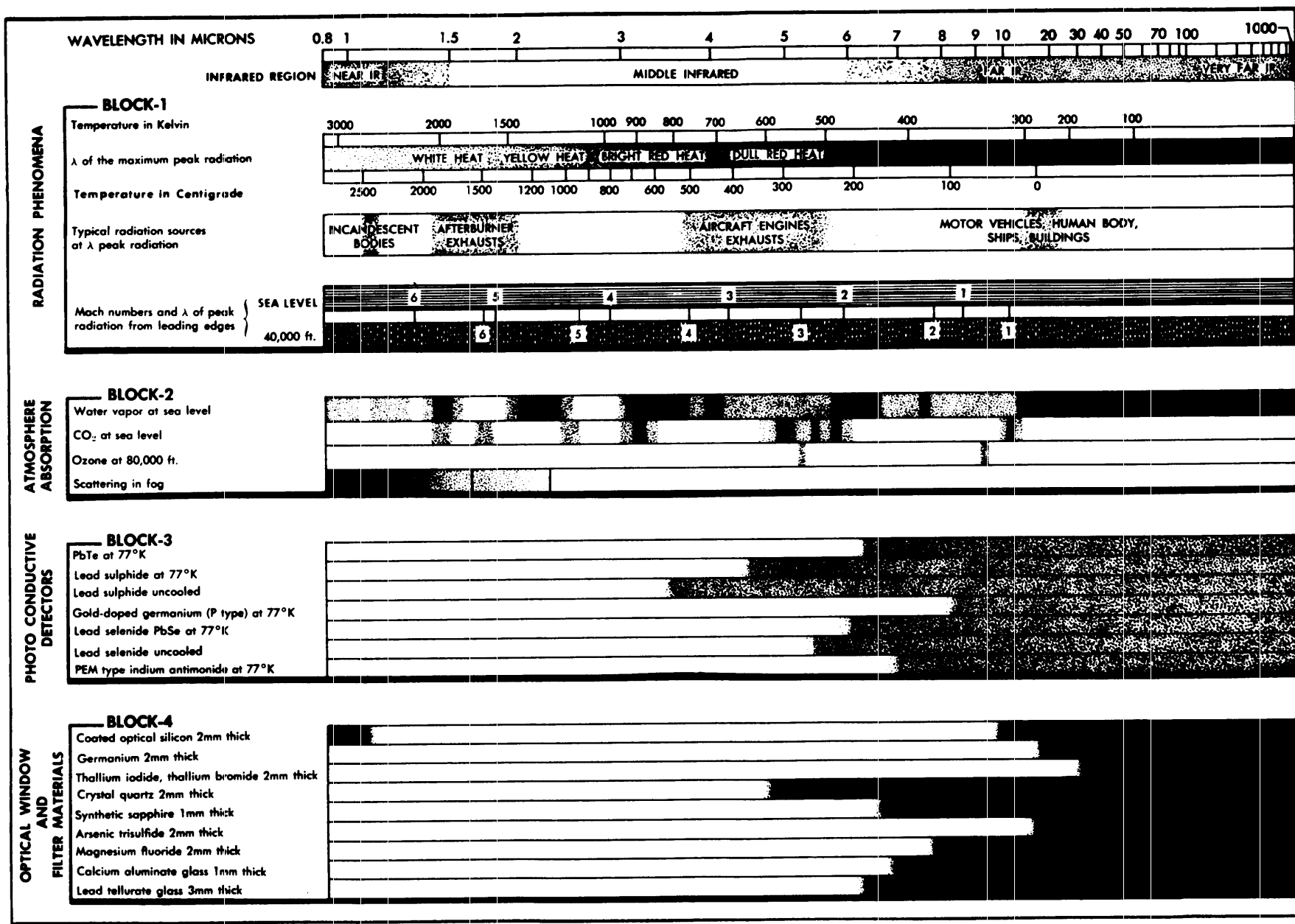

Figure 4-44. IR Data Chart.

finder device. As with radar, the distance to an object is determined by the time required for a light pulse to reach and return from a target. The narrowness of the laser beam permits sharp resolution of targets.

Laser beams can also be used for communications. Lasers can be modulated in a number of ways to encode very complex signals; the beam is then transmitted, detected, and demodulated to recover the information. Due to the narrow beamwidth, this type of communication is very secure since a receiver must be on-axis to detect the laser. In theory, due to the high optical frequencies, one laser beam can carry as much information as all existing radio channels. However, since laser beams are very highly attenuated by rain, fog, or snow, laser communication on the earth's surface is not yet entirely reliable.

ACTIVE AND PASSIVE OPTICAL SYSTEMS

An active system employs an artificial source of energy to illuminate the target. The reflected or reradiated energy is then collected by the optical receiver. A major disadvantage of this system is that it employs a powerful source of radiation which can itself be detected. Examples of active systems are searchlights, IR communications systems, laser ranger finders, headlights,

and snooper scopes. One other important example is forward-looking infrared (FLIR) systems which enable the user to view night scenes clearly. A passive system detects only the energy which is naturally emitted from the target. The advantage of a passive system is that its use cannot be detected since it emits no radiation of its own and, therefore, countermeasures are difficult to employ. Some examples of passive systems are binoculars, cameras, IR homing systems, and low-light-level television (which basically amplifies existing light).

OPTICAL EQUIPMENT

Before discussing specific types of equipment, the components of a typical system will be explained. Differences between various systems appear because each system, active or passive, is tailored to do a specific job, just as in radar equipment. The design of an optical system must consider the target radiation characteristics, the operating environment, and the type of display required. The major components of a system are the optics, a detector, a signal processor, and a display unit. These are shown in a simple schematic in figure 4-46.

System Optics. The optical component of a system performs basically the same function as the antenna of a radar. It collects the radiation from

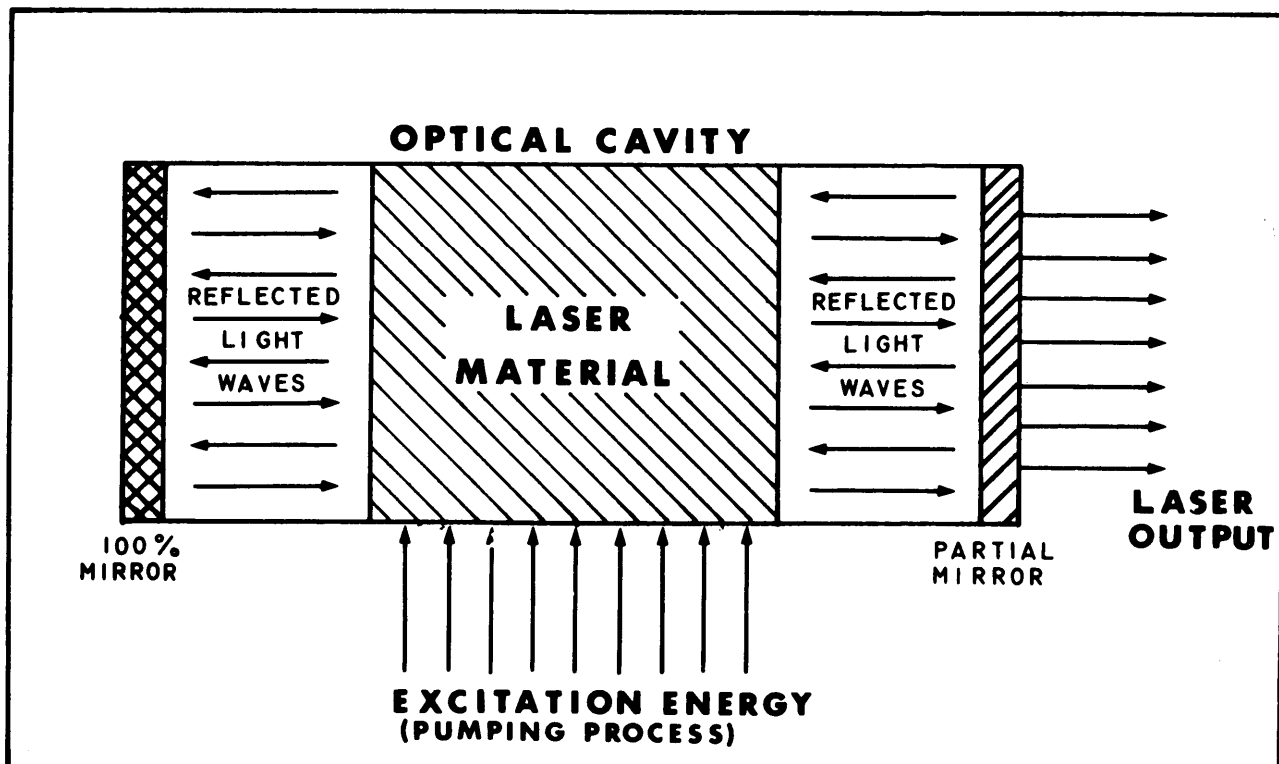

Figure 4-45. Basic Laser Construction.

the target and focuses it on the detector. Second, it has the function of keeping out or limiting unwanted radiation; that is, it improves the S/N ratio. This "antenna" for the receiver can take many forms depending on the function and operating environment. It could be a mirror, lens, prism, window, or a combination of these. In airborne IR equipment, an additional optical component (IR dome) is employed to protect the system from heating and wind blast. While protecting the system from its immediate environment, the dome must also transmit the desired IR radiation with minimum reflection or distortion and filter unwanted radiation. Usually the dome shape is hemispherical and may be cooled to prevent it from emitting IR radiation.

To provide the greatest possibility of intercepting optical radiation from a target, the receiver must have the greatest possible field of view. This in turn may create problems. The greater the field of view, the greater the possibility that the receiver may not be able to distinguish the target from other sources of radiation. A scanning mechanism may be incorporated to provide both field of view and target discrimination. Scanning the optical system achieves the same results as scanning a radar antenna—increased area coverage, better target position information, and better target-to-background discrimination. There are several scanning systems in use.

One type is a fixed optical system with a fixed field of view. This system provides indications of relative energy intensities and is most suited to warning receivers. If more than one fixed optical system is employed, each with a specific area of coverage, then rough target position can be obtained.

Another scanning system uses a moving lens or

mirror which focuses the energy from a small field of view on the detector. This lens can have any scan pattern depending on the function of the receiver—spiral or raster for searching large areas, conical for tracking. A third type of scanning system, used in IR homing missiles, employs a chopper or reticle inserted in the optical system just before the IR radiation reaches the detector. The reticle is a thin plate of optical material which has a transparent and opaque pattern on it. As the reticle is rotated, the IR energy is chopped at a rate determined by the reticle pattern. This system produces error signals when the target is not exactly centered in the field of view. Figure 4-47 is an example of a reticle pattern that can provide both azimuth and elevation information. If the IR source is located in the upper half of the pattern, the IR intensity on the detector is constant as the reticle rotates. As the pie-shaped half of the disc rotates over the target, the IR energy is pulsed and the amplitude of the pulses is an indication of relative elevation angle. When the target moves to the right or left, the pulsing starts and stops at different times, indicating target azimuth.

The optical-electromagnetic system is another technique used in many IR applications. This system produces a direct picture to the operator using a device called an image-converter tube. Here, the IR energy is converted to a picture in much the same way that a television tube converts microwaves into a picture. This is the optical system found in such devices as night vision goggles, personnel detectors, and IR binoculars.

Optical Detectors. The optics focus the radiation onto a device called a detector. The purpose of the detector is to transform this energy into

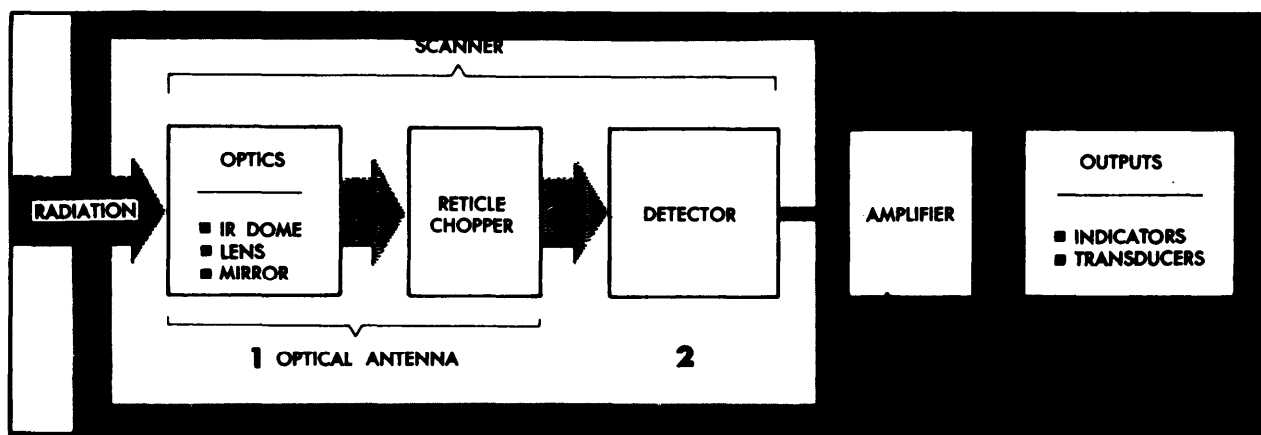

Figure 4-46. Schematic of Optical System.

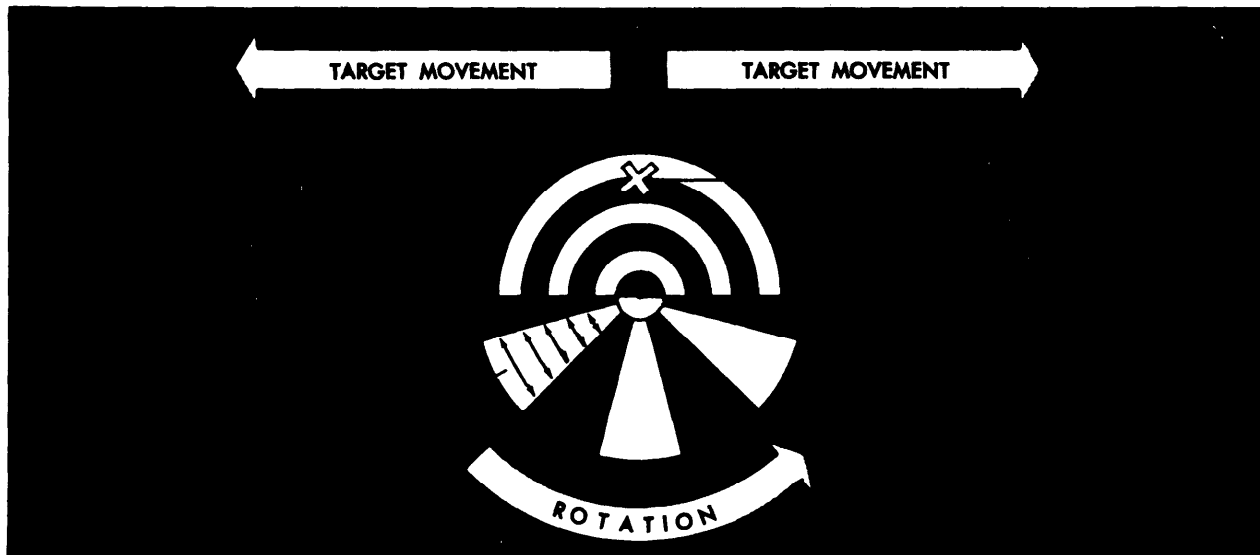

Figure 4-47. Reticle Pattern.

a usable output. Most detectors do not operate over the entire optical frequency range but are sensitive in only a relatively narrow band. For example, the human eye is receptive only to visual wavelengths while television tubes are often sensitive to visible and a small portion of the IR.

Many of the detectors that are sensitive in the Near IR region operate efficiently at ambient temperatures (remember that greater temperatures produce greater intensities in the shortest wavelengths); on the other hand, many detectors sensitive in the Middle and Far IR regions must be cooled to achieve maximum efficiency. In fact, many IR systems in use today have detectors cooled to the temperature of liquid nitrogen, 77° Kelvin. Therefore, a cryogenic system is included as part of the hardware of many IR systems.

The ability of a detector to see a specific IR source (target) is greatly affected by unwanted IR energy entering the receiver. This unwanted IR energy produces detector reactions similar to that produced by target sources. Thus, IR systems have noise problems which cause the same difficulties that noise causes in a radar receiver. There are three major noise problems. The first is target background noise. For example, an IR system for detecting aircraft jet engines must do so against a background of the sun, clouds, or the earth's surface. This kind of noise can be greatly reduced by wavelength and spatial discrimination. The second is the noise generated by the IR detector and its optical components. This noise can be eliminated by cooling. The third type of noise, and the most difficult to reduce, is that produced by

the detector and its associated electronic components.

Signal Processing and Display. The output from the detector is very weak and must be amplified before it can be displayed. The output signal is usually modulated so that conventional electronic amplifiers can be used. This modulation may take place at the source of the IR, as in communications systems, or at the receiver. The modulation can be mechanical, as with a chopper, or electronic.

The display of the amplified and processed signal can be aural, visual, photographic, or electrical, depending on the specific function of the IR system. For example, an audio signal supplied to the interphone system may be used to indicate that the IR system has located a target. IR equipment, using the image converter tube, displays the target visually. IR cameras used in reconnaissance provide photographic displays of IR radiation.

Electro-Optical (EO) Application

Radar and visual (aided or unaided) techniques are the two basic methods commonly used for target detection and acquisition. EO systems are normally used with radar to improve the total weapon system capability.

The optical system not only gives the weapon system an additional dimension, but also enhances the potential of the radar mode. Most long range optical devices inherently have narrow fields of view because of physical properties. A narrow

field of view limits a system's usefulness as a detection or acquisition device; it normally requires cuing from some external source. This cuing source is normally radar and is one of the primary reasons these two systems have been mated. If ECM, such as jamming or chaff, are successful in degrading the radar's ability to engage a hostile aircraft, the operator need only switch modes or operation and track the intruder optically. Furthermore, the capability of most present generation radars is degraded as the tracking angle between the antenna and ground gets smaller. Ground clutter increases the number of targets on the radar operator's scope, creating confusion. Moving target indicators and other similar circuits have been developed to overcome this deficiency, but they are not totally effective. As the radar presentation deteriorates because of low tracking angles, the optical system operator can assume the tracking duties. This dual capability gives the weapon system greater flexibility and severely complicates the EW officer's problem, as both the radar and optical threats must be countered simultaneously.

Most of the EO sensors discussed in this chapter have been in existence for many years. Only in the last decade, however, have most of these systems been technology exploited for use as

target detection and tracking systems. Engineers have successfully integrated the standard television (TV) system with a radar tracking system. A TV camera modified with either a zoom-type or individual long and close range lens is physically mounted to the radar antenna assembly (figure 4-48). The azimuth and elevation inputs from the TV camera and the radar are routed to a common computer which processes the data and computes the firing solution. Because the TV camera and radar antenna are comounted, the antenna positioning inputs are the same regardless of which system is actively tracking. This common reference also facilitates the cuing function necessary to effectively employ a TV system. The standard TV system is limited to daylight only operations because of its physical properties.

Low-light-level image intensification devices have been developed to aid in tracking and detection during the hours of darkness. Low-light-level TV is one of the image intensifier systems actively used in the military community. Its integration is very similar to that described in the TV discussion (figure 4-48). The perfection of low-light-level TV gives a weapon system an excellent night optical capability.

Imaging IR systems are also being rapidly perfected as an instrument of modern warfare.

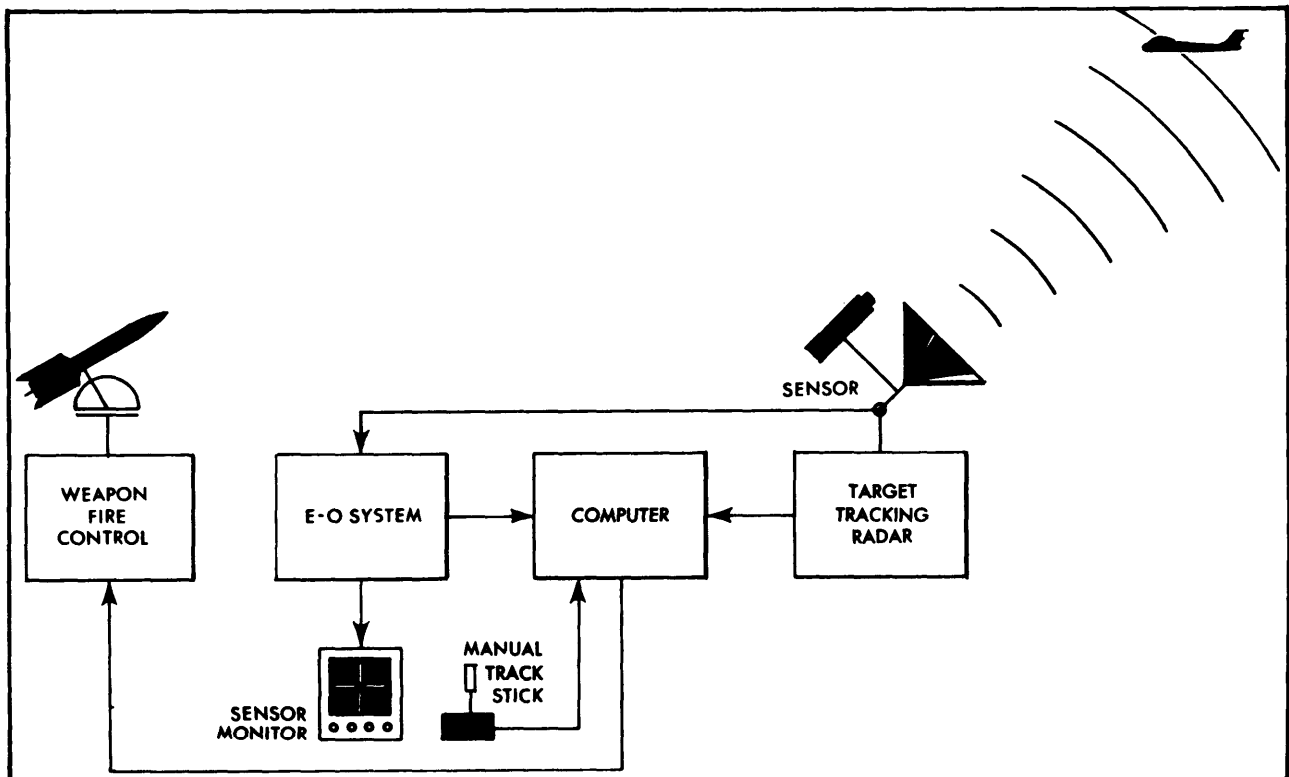

Figure 4-48. Typical Integrated System.

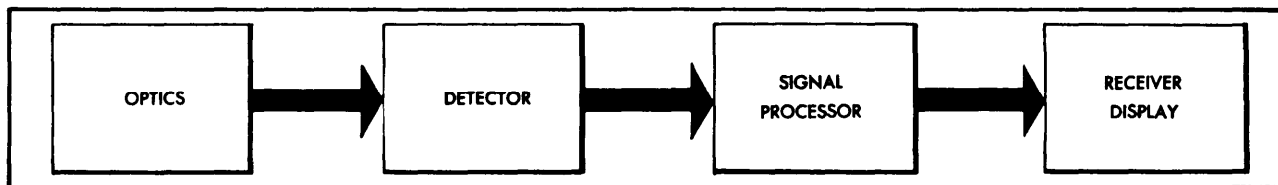

Figure 4-49. Typical Infrared Warning System.

This system differs from TV in that imaging IR senses differential radiation, while TV displays contrast. Generally speaking, an IR system will out perform a TV system and has the additional capability to operate in any light conditions.

The systems thus far discussed have been presented as being integrated with a radar system. It should be understood that these systems are fully capable of independent operation, and their application need not be limited to use with radar. However, an inherent characteristic of optical systems is their inability to accurately measure range. This is one reason optical systems are frequently teamed with another weapon system.

Advancements in laser technology have made possible the development of laser ranging systems. These systems are capable of measuring ranges to a very exacting degree. The integration of an EO system with a laser range finder creates a very precise tracking system.

Pure optics is the last system to be discussed. Simply, the operator uses standard field glasses, binoculars, or telescopes. The optical device is physically mounted to the tracking system's antenna assembly and functions in the same way as the other sensors. It too is restricted, for it must have ranging information from an external source. Although these systems are limited to daylight and fairly bright night conditions, they can provide accurate track information.

ELECTRO-OPTICAL COUNTERMEASURES (EOCM)

The increasing use of EO systems for target acquisition/fire control and weapons guidance has necessitated a vigorous program to develop countermeasures to these new threats. Countermeasures are generally characterized as optical or IR. Within each band, countermeasures are employed against the anticipated threat to make the target blend into its background (camouflage), or to hide the target from the threat system, (obscuration), or to reduce the threat system's ability to detect or track the target (degradation).

MODULATED LIGHT AS AN ELECTRO-OPTICAL/COUNTERMEASURES

Modulated light is a countermeasure that degrades the tracking efficiency of a threat weapon system employing either optical or EO tracking. The primary difference between modulated light and flash blinding is that instead of directly obscuring the target, modulated light induces tracking errors which cause the threat weapon to miss its target. If the threat system uses optics, the intensity and modulation frequency degrade the combined functions of the human eye, brain, and muscles so an accurate track cannot be maintained.

INFRARED COUNTERMEASURES (IRCM)

The primary purpose of an IR warning system (IRWS) is to detect and identify IR threats that include hostile aircraft, AAMs, and SAMs. Alerted, the aircrew member can initiate the proper IRCM actions. IRWS began in the mid-1950's, and basic investigations attempted to determine when IR flares should be launched to successfully capture an IR seeker. Because IR attacks can come from 360 degrees about the aircraft axis, receiver requirements are demanding. Receiver systems use either a search-track or a fixed field-of-view optical system to capture and focus the threat missiles on an IR detector. A typical IRWS block diagram is shown in figure 4-49. The detector converts IR radiation into an electrical signal which can easily be processed. The signal processor analyzes and measures the characteristics of the detector outputs. The displays and outputs provide the necessary information to the aircrew member for the appropriate IRCM responses.

The performance requirements for the IRWS vary for each type of aircraft. When designing an IRWS, the following factors must be considered: the basic use of the output of the system, the types of threats to be detected for all of the missions the aircraft will perform, what the information on

each threat will be used for, how fast the information must be obtained in order to be useful, and the relative merits of the various outputs of equipment for each of the missions to be performed by the aircraft. The maneuverability of an aircraft explains the requirements for these design elements and also pinpoints the most serious problem—high false alarm rates. The constantly changing contrast between the IR threat and the threat's background makes a high probability of detection with a low false alarm rate, extremely difficult to achieve.

There are several techniques that can effectively defeat or degrade an IR threat. IRCMs are specifically designed to reduce target radiation, affect the target homing ability of the IR seeker, or affect the target discrimination ability.

The most obvious means of countering an IR threat is to reduce the intensity of target radiation by operating the primary IR source at a lower temperature. For subsonic aircraft, engines are the primary IR source, with the largest emissions to the rear. For supersonic aircraft, the aircraft skin may also become a significant IR source due to aerodynamic heating, though the engines will still be the major source in the rear aspect. Additionally, afterburner operation is usually required for supersonic flight and greatly increases the IR emission at all aspects. Operating engines at low temperatures is usually not desirable from the standpoint of operating efficiency. Reducing supersonic aircraft speed would normally degrade the tactical capability. Directly reducing the radiation level is possible by not operating afterburners, but again, the tactical considerations may make this undesirable as an IRCM.

A more feasible approach involves the use of a shield between the radiation source and possible threat detectors. This can be done directly on ground equipment by placing the exhaust pipe and muffler of a vehicle on the underside, or indirectly by erecting a mound of soil or sandbags around and artillery emplacement. On an aircraft, shielding may require shrouding the aircraft exhausts or using a bypass-type engine. Increasing the size of the condensation trail of the aircraft attenuates the IR radiation of the tailpipe as much as 50 percent. Unfortunately, the major portion of the IR radiation comes from the exhaust plume when afterburner is used, and this radiation is very difficult to shield.

Emitting smoke with the engine's exhaust is also used as an IRCM. The smoke diffuses the engine's IR radiation to a level below that which the threat seeker head is able to detect. Although this

technique may decrease the IR detectability of the aircraft, it will most certainly increase its visual detectability in clear air and should be used with extreme caution.

Because IR radiation is EM, it can be jammed with techniques similar to those used to counter radar. Jamming system designs incorporate both masking and angular deception techniques.

Flares have been developed to counter both IR homing missiles and IR tracking systems. When a penetrator detects an IR attack, flares are ejected from the target aircraft to create an IR energy source greater than that radiated by the aircraft's engines. As the burning flare drops down and away from the aircraft, it presents a more inviting target to either the IR receiver on the interceptor aircraft or the IR seeker in an attacking missile. When used properly, flares cause the IR threat to track the false target, enabling the target aircraft to fly out of the seeker's field of view.

Interposing clouds or a fog bank between the plane and the threat can also be an effective countermeasure. As was explained earlier in this chapter, atmospheric water vapor attenuates IR radiation; therefore, clouds or fog can reduce the radiation level below that required for seeker lock-on. The water vapor in the detection path will either partly or completely scatter the aircraft's IR radiation.

Another IRCM uses a powerful IR source, such as a lamp, that can be installed on the tail of the aircraft. By blinking this lamp on and off at the proper rate, an IR homing missile can be deceived in much the same way that a radar can be angle deceived. The advantage of this type of IRCM is that the supply does not run out.

Tactical maneuvering is another form of IRCM. The aircraft may be able to evade the IR seeker's field of view, or it may maneuver so as to place the missile IR detector's view into the sun. If the latter maneuver is successful, the missile's IR seeker will not be able to separate the aircraft radiation from the background radiation and does not know where the target is located. Maneuvering also would include the ability of the aircraft to use terrain masking to screen itself from the seeker field of view.

OPTICAL COUNTERMEASURES (OCM)

OCM deals with the visual spectrum. If a pure optical system is employed by the hostile force, the countermeasure must be directed at the person operating the threat; if the system is EO, the countermeasure technique is tailored to and

directed at the electronic hardware. Because optical systems are passive (that is, they receive only and do not radiate), their presence is extremely difficult to detect. Additionally, if aircrew members are successful in detecting the tracking device, they have very little information on which to evaluate the effectiveness of the countermeasure. For example, when aircrew members employ jamming techniques to counter a radar threat, the monitoring of the aircraft receiver may indicate the effectiveness of the jamming. Such feedback information is rarely available when confronted with an optical threat. However, like every piece of hardware, EO has weaknesses that are exploitable. The following countermeasure techniques take advantage of these factors.

EO systems are dependent on clear visual conditions for optimum performance. They all exhibit a very limited capability to see through clouds, rain, smoke, haze, or other similar atmospheric conditions. Natural factors such as these are classified as obscuration countermeasures. Terrain masking is also included in this category. Smoke bombs have been successfully employed at low altitudes to screen aircraft. Any technique that successfully denies an optical system a look at the target aircraft is an effective countermeasure. Natural factors such as these should be employed at every available opportunity.

Camouflage countermeasure techniques have been employed by military forces for many years. Aircraft are normally camouflaged with various paint schemes; the colors and patterns are dependent on such factors as background, aircraft flight altitude, and type of threat expected. Camouflage techniques are designed to prevent target acquisition and generally are of little value once the aircraft is being tracked. Because most of the factors considered in a camouflage design are variable, it is difficult to maintain the optimum paint scheme for sustained day-to-day operations.

Some EO devices are light sensitive. An aircraft-mounted high intensity lamp may be able to permanently damage component parts of these systems by overloading the circuitry. Some low-light-level TVs are particularly susceptible to this technique. Flashing lights may also destroy the quality of a TV picture.

Tactical maneuvering can also be an effective OCM. The aircraft may be able to evade the optic's field of view, maneuver into some natural phenomena, such as a cloud, or duck behind a hill to take advantage of terrain masking.

Human factors are also subject to exploitation. For example, the human eye is not able to look directly into the sun. In a daytime environment, the aircraft should select an attack heading that places the sun in the aircraft's 6 o'clock position during the most vulnerable phases of the mission.

As laser technology advances, so does the potential countermeasure technology. The following are all possible laser countermeasures: absorptive filters, ablative coatings to protect aircraft and missiles against high-power laser weapons, broadband optical noise source to disrupt laser communications systems, missiles that can home on laser beams to destroy the transmitter, absorptive and nonreflective coatings to reduce the optical backscatter of illuminated targets, laser repeaters and other types of jammers, optical decoys, optical chaff, and atmospheric seeding with substances that can absorb laser energy and cause atmospheric blooming.

SUMMARY OF ELECTRO-OPTICS (EO)

The introduction of sophisticated warfighting systems which include EO tracking capabilities has dictated the expansion of OCM equipment and techniques. The primary problem associated with EO operations is the inability to determine when a threat exists even though several techniques are available to counter the threat. If aircraft attrition rates are to be maintained within acceptable limits, all available OCM should be employed when aircraft penetrate a hostile environment.

ELECTRONIC WARFARE INTEGRATED REPROGRAMMING (EWIR)

As you have noted, EW is expanding by leaps and bounds. New threat systems and countermeasures against those systems are being developed at a rapid rate. To improve the response time to threat changes and reduce the cost involved in developing countermeasures, the use of computer systems with reprogrammable capability are being built into the EW avionics systems of today.

In this section, you will be introduced to the conceptual framework of EWIR. You will learn the objectives of EWIR and what is required to support this extremely important concept that supports EW.

The intent of EWIR is to rapidly reprogram our EW systems in response to threat changes and to provide the operational commander with EW

systems that will effectively counter the threat.

Since 1970, the Soviets have placed more than 25 new fire-control systems (AI, SAM, and AAA) into service and have changed or improved most existing systems. We must have EW equipment that can respond to these changes as they are discovered. The threat is continually being improved in parametric agility and processing techniques that are extremely difficult to jam. As a result, the development of computer-based systems started in the early 1970's with the AN/ALR-46 RWR. However, at that time, there was no real support available to provide immediate update for this system or other systems being developed. It was not until 1975 that a real attempt was made to provide support for this system and other similar systems. The initial support request was denied at the Air Staff level because no intelligence support was identified in the concept. It was not until 1977 that the concept was reevaluated and a new support request written. It was noted that extensive intelligence support was needed and that two significant problems required solutions: a reliable intelligence information flow and a data base.

Intelligence Flow

A threat change, which includes new threats and parametric characteristics changes in old threats, to include ECCM, is one aspect of these intelligence problems. The time lag from when the new threat or change becomes operational until a change in our systems is made is another aspect of these intelligence problems. The time lag from which the new threat or change becomes operational until a change in our systems is made is another aspect of these intelligence problems.

In 1975, Air Force Intelligence (AF/IN) did an initial survey of Air Force users to find out what was needed to support their reprogramming efforts. From this survey, the following requirements were developed:

- (1) A single manager for the data.
- (2) Reported data—ELINT.
- (3) Assessed data—projections made by Scientific and Technological (S&T) centers as to how equipment operates.
- (4) Extensive detail, when available, on how systems operate to allow for reprogramming of systems.
- (5) Unique formatting—to allow use of data as required.

To obtain the intelligence needed, the Air Force

has to go to other agencies for help. These agencies include:

(1) Defense Intelligence Agency (DIA). DIA has overall responsibility for the production of S&T intelligence. DIA tasks each service's S&T centers to do analysis in specific subject areas. The following S&T centers are under DIA:

(a) Army S&T — does analysis on all SAM and AAA systems through the Missile Intelligence Agency (MIA) and Foreign Science Technology Center (FSTC);

(b) Navy S&T — does analysis on all naval threats through the Naval Intelligence Support Center (NISC); and

(c) Air Force S&T — does analysis on all AI and EW/acq systems through the Foreign Technology Division (FTD).

(2) National Security Agency (NSA). NSA is responsible for all SIGINT. When the Air Force requires the analysis of a new or old weapon system, it must request NSA to provide the SIGINT to the appropriate S&T center; however, before doing this, approval from DIA must be obtained. Once permission is granted, SIGINT transfer to the S&T can occur. Figure 4-50 displays the "big picture" of agency interaction.

Data Base

To tie all the intelligence sources together, the Assistant Chief of Staff for Intelligence (ACS/I) tasked FTD to be the overall manager for the "data base" and to begin analysis of AI and EW/acq radars. Next, the Air Force requested the DIA to support the Air Force EW data base. DIA obtained support from the S&T centers and

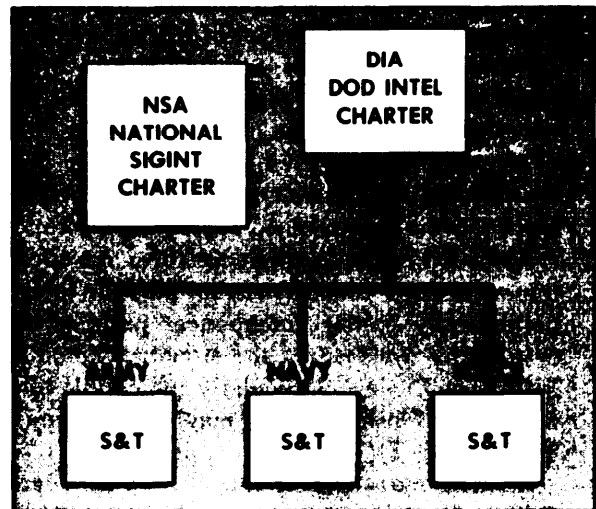

Figure 4-50. Intelligence Agency Interaction.

requested NSA to supply SIGINT information. Finally, Air Force Plans and Operations (AF/XO) requested the Air Force Electronic Warfare Center (AFEWC) to gather blue/gray data that would also be needed for the data base.

The Air Force EW data base became operational in 1978 and provides a single source of intelligence information for the users, which are primarily SAC, TAC, and the R&D community.

Air Force Logistics Command (AFLC)

In early 1974, the Air Staff established a policy-making AFLC, responsible for all reprogrammable airborne EW systems.

In 1975, a program management directive was issued to establish the operation of the Electronic Warfare Avionics Integrated Support Facility (EWAISF) to be located at the Warner Robins-Air Logistics Center (WR-ALC). The EWAISF is the primary support facility for all present and future airborne EW reprogrammable systems. The EWAISF is a facility containing complex, special, and general purpose equipment. It houses the operational, logistics, technical, and management personnel. This central facility provides a capability to perform multiple and simultaneous EW software changes on diverse operational equipment.

EWIR and EWAISF Concept

With the intelligence flow identified, the data base established, and AFLC support requirements established, the Air Force published its Electronic Warfare Integrated Reprogramming Concept (EWIRC) in 1977. The EWIRC, implemented in AFR 55-90, July 1982, describes interfaces and information exchanges between appropriate agencies.

A dynamic threat environment conjoined with changing technology necessitates the EW systems to undergo both periodic and emergency changes. The EWIRC, primarily through the EWAISF (WR-ALC), provides for this change in an expeditious manner.

Area Reprogramming Capability (ARC)

To shorten the time required to reprogram systems even further, AFSC is trying to provide in-the-field capability to reprogram electronic combat systems (ECS). Both SAC and TAC have submitted statements of operational need (SON) requesting this capability. The idea is to give each MAJCOM the capability to reprogram, thus allowing the operational commands to use it where necessary.

The EWIR is an important and growing concept for EW. As defense networks become more complex and offensive systems more demanding, the necessity to reprogram weapons as they enter a combat area will become mandatory.

Joint Electronic Warfare Center (JEWEC)

The JEWEC was established in San Antonio, Texas by the JCS based on DOD needs in planning and developing joint EW concepts, tactics, procedures, techniques, exercises, and tests. As established by the JCS, the mission of the JEWEC is to provide, upon request, comprehensive analytical support to the EW aspects of military operations and EW technical assistance to the Secretary of Defense, JCS, military services, verified and specified commands, and other DOD agencies. All of the support is provided "upon request." Representatives from the NSA and DIA are present at the JEWEC.

Chapter 5

SUPPRESSION OF ENEMY AIR DEFENSES (SEAD)

SEAD

This chapter describes SEAD, the third component of EC. SEAD is that activity which neutralizes, destroys, or temporarily degrades enemy air defense systems in a specific area through physical attack and (or) EW, thus enabling air operations to be successfully conducted. Joint-SEAD (J-SEAD) operations employ both Army and Air Force assets to suppress those enemy surface-to-air defenses which influence the tactical air-land battle.

Due to the proliferation of enemy air defense systems, the ability to rely on one element of EC for successful mission accomplishment does not exist today. As discussed earlier, these defenses include SAMs, AAA, AIs, associated data gathering/support systems (such as early warning, GCI, acquisition, and HFRs), and associated C³ links. A well-planned and effectively coordinated use of self-protection techniques, destructive suppression options, and dedicated EW support assets must be integrated into all mission scenarios. The enemy's ability to apply ECCM techniques to its air defense systems makes self-protection jamming and other EW techniques less effective. Therefore, destructive countermeasures become an important option when attempting to suppress (either permanently or for a specified time period) certain vital components or links of the enemy's air defense systems.

The definition of SEAD includes two major options: physical attack and EW. Actions which neutralize or degrade enemy air defense systems are discussed in the chapters on EW and C³CM. The rest of this chapter discusses the destruction of enemy air defense systems. Destruction can be accomplished by a wide variety of ground-based and airborne delivery systems, such as rockets, missiles, drones, aircraft, and artillery.

Destructive SEAD resources are systems designed to destroy or suppress the extensive and varied elements of the enemy's Integrated Air Defense Systems (IADS). Our past practice was to concentrate the destructive elements on the threat radars. Previous conflicts, such as Arab-Israeli War 1973, demonstrated that this limited view must be expanded to encompass all aspects of IADS. Besides threat radars, we must now include indirect threat radars (EW, GCI, and

HFR), C³ radio links, passive detection systems, and associated weapon systems (whether they are radar, EO, or visually guided).

Both the Army and Air Force have unique suppression capabilities which, when coordinated, result in a program known as the J-SEAD. Army and Air Force systems are integrated to suppress enemy surface-to-air defenses. Responsibilities for suppression are determined based on system capabilities, threat, and mission objectives. The Army conducts J-SEAD operations primarily near the forward line of troops (FLOT). The Air Force J-SEAD operations increase with distance beyond the FLOT to compensate for the decrease in Army suppression capabilities (figure 5-1).

Various systems are used by the Air Force and Army for SEAD operations. Each service has different types of systems it can employ. The first type includes airborne destructive resources ranging from small, relatively inexpensive drones to complex combinations of airborne and ground-based systems.

A typical airborne destructive resource is a low cost, expendable drone capable of extended loiter time near known or suspected targets. Examples of targets include radars, ground-based jammers, or communications nodes. If equipped with the capability to home on and destroy RF emitters, the drone would force the enemy operator to limit or shut down its operation. The threat of this possibility may cause confusion and force the enemy to expend valuable resources against this inexpensive potential threat.

Another system representative of airborne destructive resources is the F-4G Wild Weasel. This self-contained system uses the APR-38 wideband receiver in conjunction with a radar bombing and navigation system. It is capable of delivering a wide variety of ordnance including ARMs, EO weapons, and conventional bombs. The Wild Weasel's primary mission is to locate and destroy or suppress hostile threat emitters (figure 5-2).

The AGM-45 (SHRIKE) and AGM-88 (HARM) are two ARMs used for the suppression and destruction of enemy air defenses. Both weapons feature a passive guidance mode, but the HARM has an in-flight retargeting capability and increased emitter coverage. The AGM-88 is also more maneuverable and capable of higher

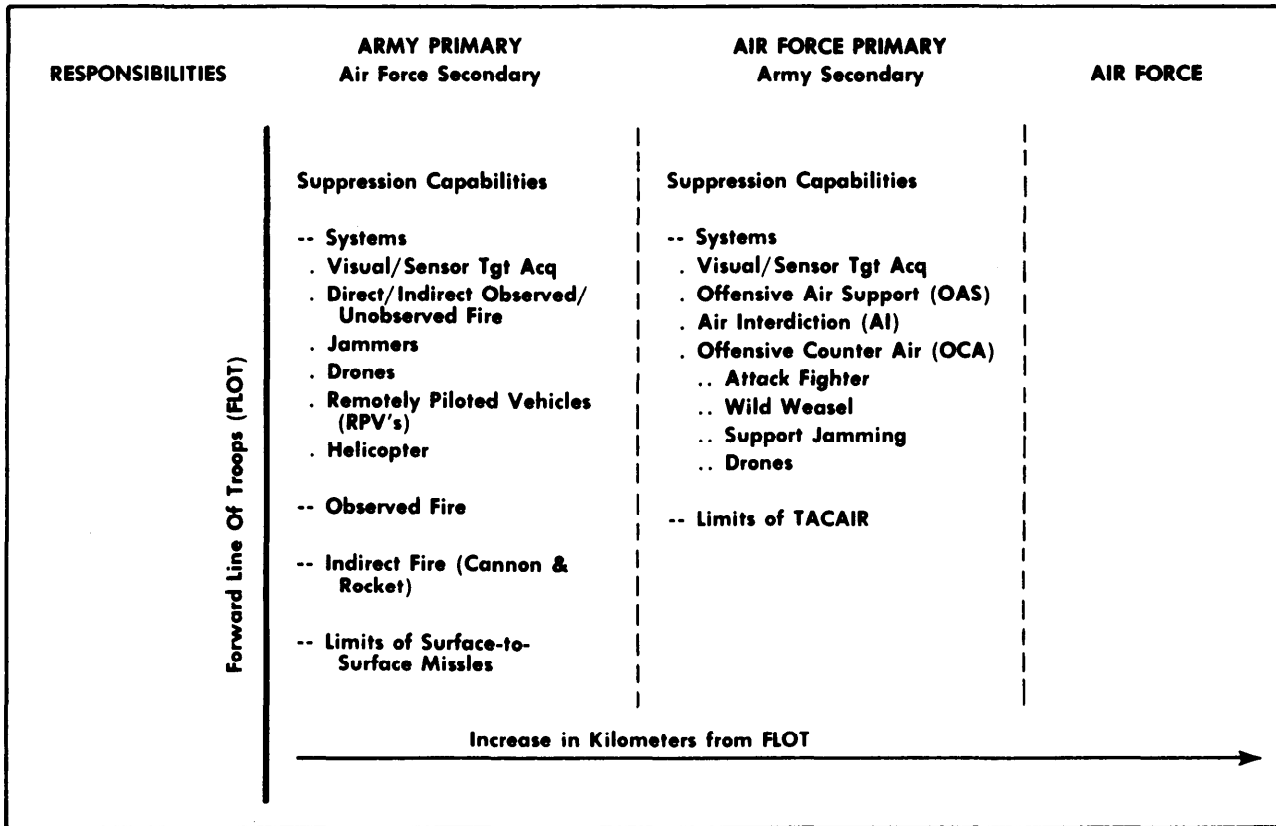

Figure 5-1. J-SEAD Suppression Capabilities and Responsibilities.

velocities than its predecessor.

The Army has primary responsibility for J-SEAD from the FLOT to the limits of observed fire. The Air Force has secondary responsibility. The Air Force has primary responsibility for J-SEAD beyond the limits of Army indirect fire (cannon and rockets) capabilities.

The first two systems, drones and Wild Weasel aircraft, are basically self-sufficient because they can accomplish their mission with on-board equipment and ordnance. However, other systems being developed are considerably more complex. They require both ground-based and airborne equipment. These systems provide the tactical Air Force with an all-weather, day/night, near-real-time integrated target location and strike capability. The specialized equipment aboard highly instrumented aircraft detects electronic emissions from enemy air defense radars and relays that data to a ground-based processing and control center. The center analyzes the data and correlates it with inputs from other aircraft to identify and pinpoint the location of enemy radars. This processed target information is then provided to tactical units for both target assignment and improved command and control procedures. The strike

capability for this system relies on two options: standoff weapons or direct attack aircraft. In the standoff option, the control center directs a strike aircraft to a standoff launch point and then guides the selected weapon to the target. In the direct attack option, the control center guides specially equipped aircraft to the target and tells it when to release its ordnance. This system also has the capability to attack nonemitting targets that have been precisely located through other means such as photogrammetric targeting techniques (figure 5-3).

In addition to these systems, which are specifically designed to destroy radiating targets, other systems can be used to suppress and destroy enemy air defenses. Ordnance delivered by aircraft, such as the F-4, A-10, F-16, or F-111, could fulfill this role. Cruise missiles could also be targeted specifically against the enemy air defense networks.

Another system for consideration within the Army's SEAD role is its attack helicopters. The helicopters would be employed either as maneuver elements or combat support elements in direct support of ground maneuver units. Attack helicopters are armed with a turret-mounted or

aimable gun system or stowed weapons, such as precision guided missiles, forward firing guns, and unguided rockets on wing store stations or "hard points."

A final consideration for airborne resources is AIMs, such as Sparrow (AIM-7), Sidewinder (AIM-9), or Phoenix. These systems, with tactical aircraft, would be used against enemy AIs, an integral part of their defense systems.

The second type of systems for J-SEAD are ground-based systems. This type includes cannons, rockets, and missiles which might be used in SEAD roles. At present, the most prevalent artillery cannon is the 155 mm howitzer, which provides all artillery direct support fire. The 8-inch (203 mm) howitzer presently provides general fire support. New howitzers with extended range capability and a high volume of fire (burst) are being developed. In a SEAD role, these systems would be limited to targets in close proximity to the forward edge of the battle area (FEBA). The current projectiles are the high explosive (HE) unitary round, the DP-ICM (with the M42 shaped-charge submunition), the rocket-assisted projectile (RAP), and the smoke round. Some

projectiles still under development are the Copperhead Cannon Launched Guided Projectile (CLGP), used for precise attack systems, and the standard 8-inch DP-ICM, to be used with a developmental 8-inch cannon. The Copperhead is a precision projectile designed to be launched from any conventional 155 mm howitzer.

Rockets and missiles are also part of the ground-based phase of suppression. The Army's Multiple Launch Rocket System (MLRS) has to be considered for use within the SEAD role. Its application will be determined by its final configuration of guidance and warhead combinations. The Lance missile (non-nuclear) has also been considered (with some alterations) as a possible long-range supplement to cannon artillery.

In conclusion, destructive considerations cover a broad range of targets, such as specific emitter sites, acquisition nets, or C³ links. With the continuous upgrading and expansion of the enemy's air defense systems, the integration of airborne and ground-based destructive assets into the EC environment is essential if an IADS is to be defeated.

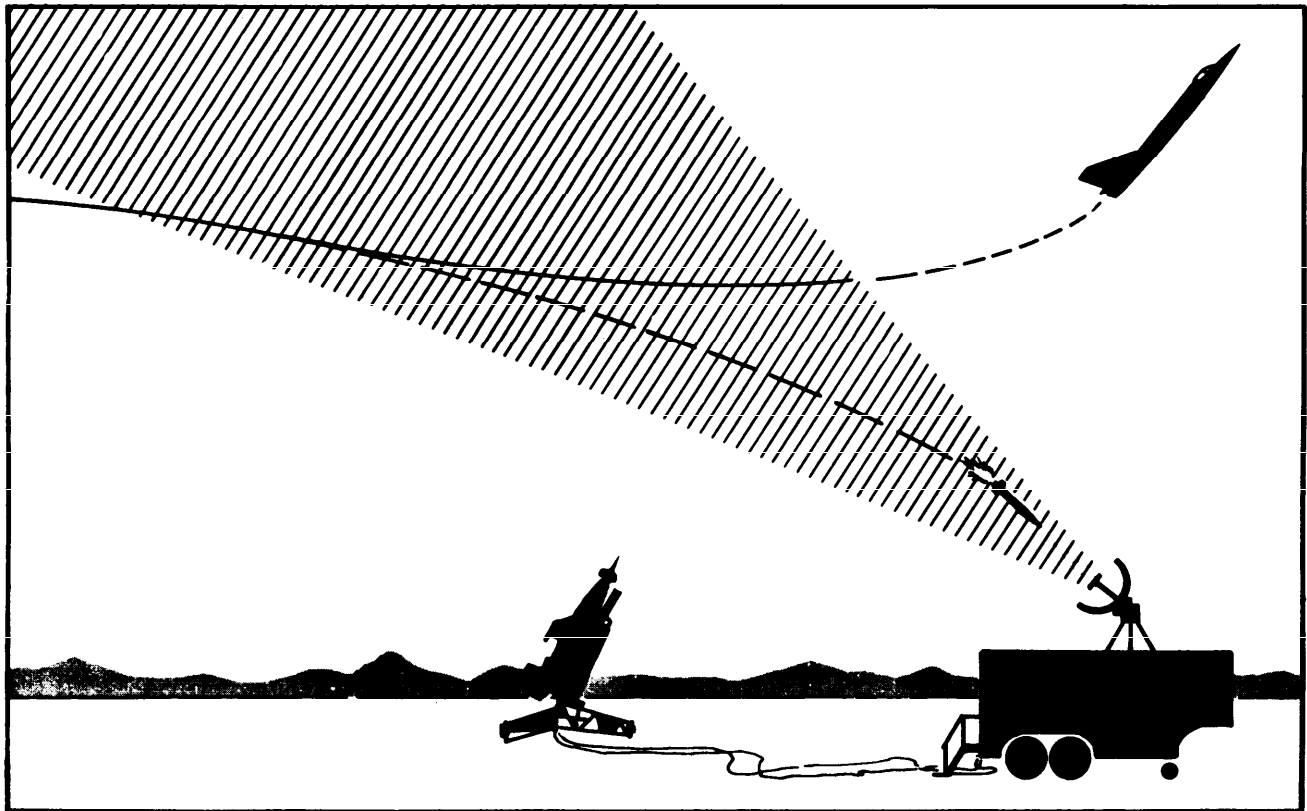

Figure 5-2. Radar Busting.

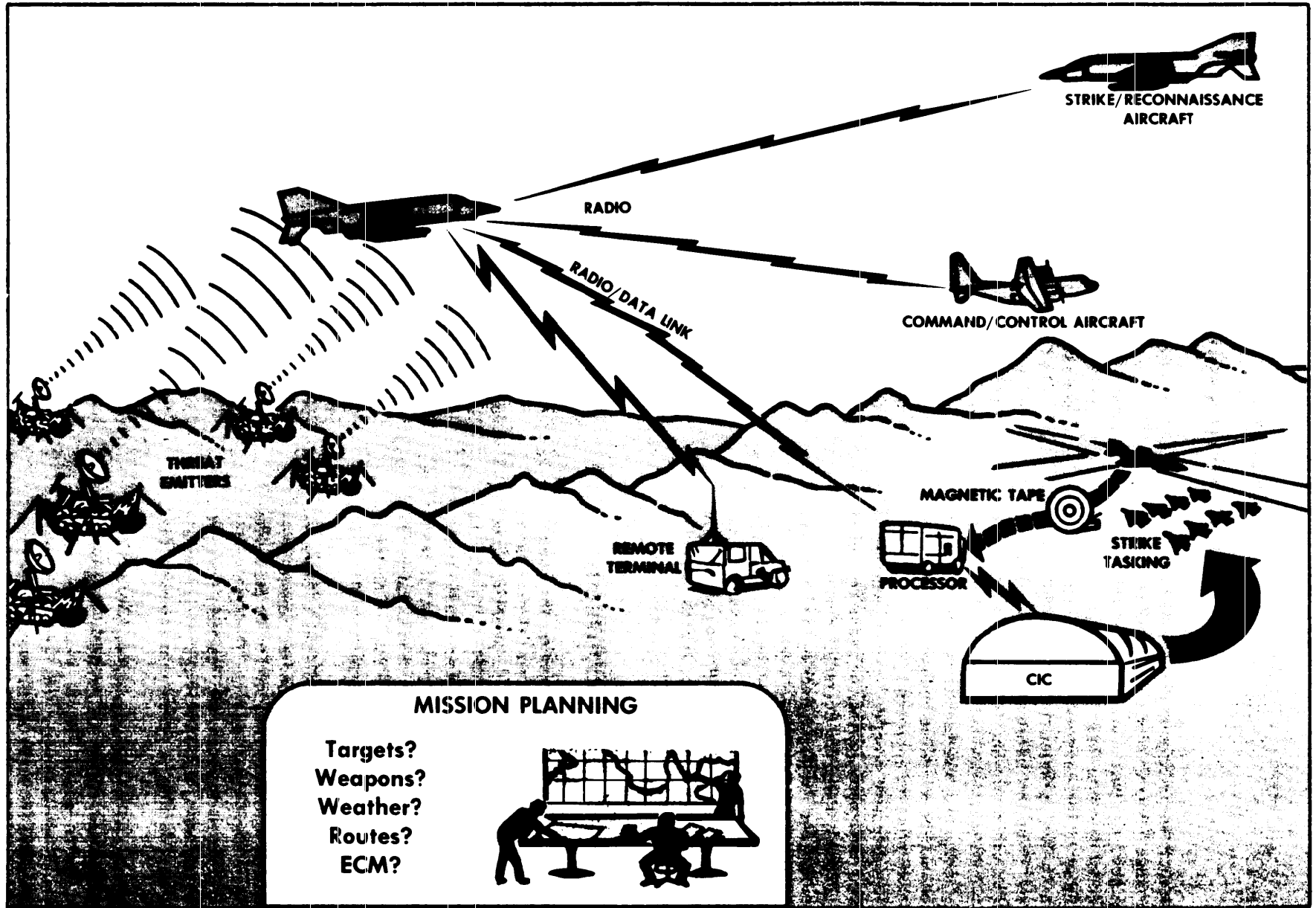

Figure 5-3. Combined Airborne and Ground-Based System.

Chapter 6

AIR DEFENSE WEAPON SYSTEMS

An air defense system may begin its activity with long-range EWRs detecting an approaching force. With good equipment and favorable conditions, the initial detection range can be over 300 miles. As the attack force approaches, HFRs and EWRs begin to feed position information to control centers. From this information come predictions of approach routes and target areas. SAM and AAA units with predicted routes are brought to ready status and assigned targets. Fighter interceptors may be scrambled and guided to positions for intercepting the approaching force.

Each defensive weapon system, whether a manned interceptor, SAM, or radar controlled gun, depends upon certain radar principles and techniques for its target tracking and intercept capability. Analysis of these defensive principles and techniques allows the development of effective countermeasures equipment and tactics for use against these systems. The following are general descriptions of these weapon systems and the tactics designed to counter them.

AIRBORNE INTERCEPTORS (AI)

Because of its range capabilities, the manned AI is generally the first of the air defense weapon systems to pose a threat to an attacking force. Technology has not yet been able to fit into the confines of a high-speed airframe a radar system which is capable of the complete task of target location and interception at extended ranges. To discuss the AI as a weapon system, it is necessary to start with the radars which control the intercept.

AIs may be assigned to defend a block of airspace covering several hundred square miles and extending from ground level to the maximum altitude of the penetrating force. The problem for the GCI net is to locate and maintain track on a relatively small, high-speed target while maneuvering its AIs into a position to intercept that target.

Although AEW platforms such as AWACS are being deployed, current GCI systems use ground-based search and HFRs to locate and track targets. Simultaneously, the ground system launches and tracks its AI through the use of a radar beacon, "IFF," to ensure a constant, strong

echo from the AI's small radar cross-section even at low altitudes and extended ranges. Tracking data from the AI and the target are fed into a computer which determines intercept position and issues commands to the AI.

The GCI phase usually coincides with the time for the penetrating force to initiate its countermeasures. Electronic jamming and chaff against the ground control radar elements can result in interruption or degradation of track data. Use of decoys is also a good countermeasure by saturating or diluting the GCI radars with false targets in a GCI environment. Overall success depends upon the magnitude and effectiveness of the ECM effort compared to the density or capability of the GCI radars.

While not capable of controlling the complete intercept problem, the modern AI does have a significant and increasingly effective radar capability. Advanced airborne fire control radars used by interceptors have long-range target search and target track modes of operation.

The search mode uses a relatively wide antenna pattern which may be visualized as a floodlight and is used to search an area in front of the AI. Various search patterns may be used, but the purpose remains the same; to pick up a target after the ground radars have directed it to a narrow portion of the defense sector. Additionally, the search mode gives the AI a limited target detection capability when GCI is not available or is ineffective. Technological advances have increased the search capability of interceptor radars to ranges of 100 NM or more. Since the search mode does not provide the precision required to ensure effective weapon employment, the radar is also provided with a target tracking mode (figure 6-1).

When the AI closes to an appropriate range, the radar is switched from search to track mode in order to feed accurate range data into a fire control computer or provide the pilot with a display of target range and relative position. Various scanning techniques may be used for target tracking. The first of these is conical. This technique is used to derive target angular information using a narrow beam antenna feed that is rotated to describe a cone in space. When the received target echo signal is constant during the scan period, the target is along the cone

centerline and the target angle is zero. Another tracking system uses two antennas; in this system, the radiating antenna transmits a steady beam while the second antenna receives only. This approach is used to defeat ECM systems designed to work against the conical scanning radars. A third scan type is the fixed forward scan, commonly known as range-only radars. Fixed scan radars date back to the first use of airborne fire control radars. Radars of this type do not have search/track modes and are used to supplement either optical or IR sighting systems on less advanced aircraft. Track mode range capabilities extend up to half the range of the search modes on some radars, but generally, the track mode is not used until the AI has flown into the effective range for its armament. The main reason for this defensive net procedure is to prevent the intruding target from employing ECM and quickly escaping from the AI narrow tracking beam. Escape from the wider search beam is more difficult.

The technically advanced AI radar incorporates various ECCM designs. Typical of these are high-rate frequency agility and track-on-jam. Fre-

quency agility enables the AI radar to evade narrowband jamming. Track-on-jam features enable the AI to use target jamming for azimuth information. Sophisticated pulsing techniques provide additional resistance to jamming and increase accuracy as well. Application of Doppler principles helps to reduce the effects of chaff and gives better capability against targets which fly low in an attempt to hide in the radar ground clutter.

In addition to providing target track data, the AI radar may also provide guidance information to an AAM. The AAM is now the primary AI weapon, although guns are still often carried.

AIR-TO-AIR MISSILES (AAM)

Unguided air-to-air and air-to-ground rockets were commonly used during WW II; however, toward the end of that war, the Luftwaffe introduced one of the first workable attempts at a guided air missile. Guidance commands were sent to the missile via thin copper wires which unreel from the firing aircraft (this system is still

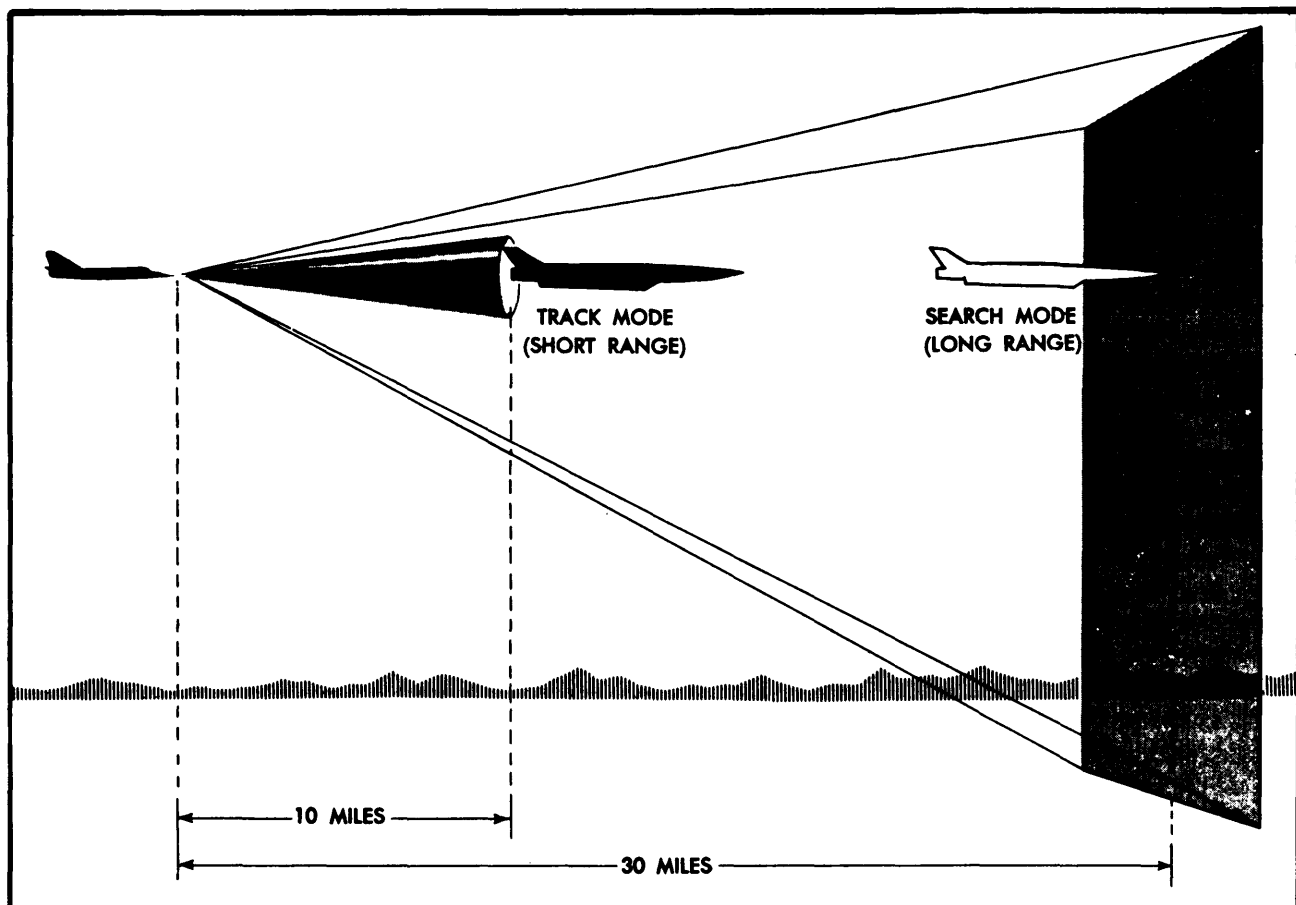

Figure 6-1. AI Search Mode vs Track Mode.

in use today with certain antitank weapons). The free-flight missile had to await development of electronic component miniaturization, and the first practical AAM appeared in the 1950's. It was somewhat bulky and not very effective, but the advances in electronics since then have produced an inventory of AAMs with impressive capabilities.

At present, two methods are employed to provide defense against attacks by aircraft equipped with AAMs. One method is to evade or outmaneuver the missile, while the second method relies upon the application of ECM to degrade the missile's guidance system. Four guidance systems are used in AAMs. They are: (1) command guidance, (2) active radar homing, (3) semiactive radar homing, and (4) IR homing. Figure 6-2 presents a pictorial summary of these guidance techniques.

Command Guidance

Command guidance systems were used in many of the first operational guided missiles, not only in AAMs but also the radio-command glide bombs developed during WW II. In a command guidance system, missile commands are generated external to the missile. A disadvantage of this system is the requirement to track both the missile and the target to determine necessary intercept commands. A variation of this technique eliminates the need to maintain track on the missile by relying on what is called a beam rider technique.

The beam rider missile stays within the beam of an AI radar while the radar maintains track on the target. During AI target tracking, the centerline of the conical scan pattern follows the target the AAM is launched into the center of the radar's scan pattern and flies toward the target. Because of the movement of the scan pattern centerline while tracking and the missile's flight characteristics, guidance commands are necessary to keep the missile on centerline. These commands can be built into the scan pattern by dividing the scan pattern into quadrants, and each quadrant is identified by a distinctive marker pulse. Antennas in the tail of the missile receive the pulses which are then transformed into missile guidance commands.

Countermeasures against the beam rider guidance systems are directed against the AI's tracking radar. Electronic jamming can obscure the radar echo and cause the AI radar to break lock. The use of chaff can cause the tracking radar

on the AI to lock on to false targets allowing the intruder to change altitude and direction while remaining undetected. In either case, the desired effect is that the centerline of the scan pattern from the tracking radar is no longer on the intruder target.

Active Radar Homing

Active radar homing is contained within the missile and is a complete guidance system. Essentially, the missile carries its own miniature radar transmitting and receiving unit. Before missile launch, countermeasures are directed against the AI's radar; however, after missile launch, countermeasures are directed against the missile's radar, with jamming and chaff. The physical size of a radar homing missile limits the number of missiles an AI may carry, and the short tracking range of the miniature radar transmitter limits its effectiveness.

Semiactive Radar Homing

Semiactive radar homing guidance is used extensively in modern AAMs and combines principles from both the beam rider and the active radar homing missile. Target tracking is established by the AI's radar and the AAM is launched when the target comes within its effective range. During missile flight, the AI maintains track on the target, and reflected radar returns are received by the missile. Guidance commands are generated within the missile from these returns, and the AAM guides to the target.

ECM may be directed against the AI radar or against the receiver in the missile. With this system, should the intruder track be broken, the AI radar may be returned to search mode where the broader search beam will probably illuminate the intruder target. Thus, the missile is able to receive searching radar returns from the intruder target.

IR Homing

All objects having a temperature above absolute zero emit IR radiation, and IR homing missiles depend upon energy radiated from the engines of the target aircraft. It is known that jet engine operating temperatures produce a broad band of IR wavelengths, but the major portion of the emissions occur within a narrow band of frequencies. By developing IR detectors sensitive at these frequencies, guidance systems are tailored to the IR radiations from aircraft engines. An IR dome

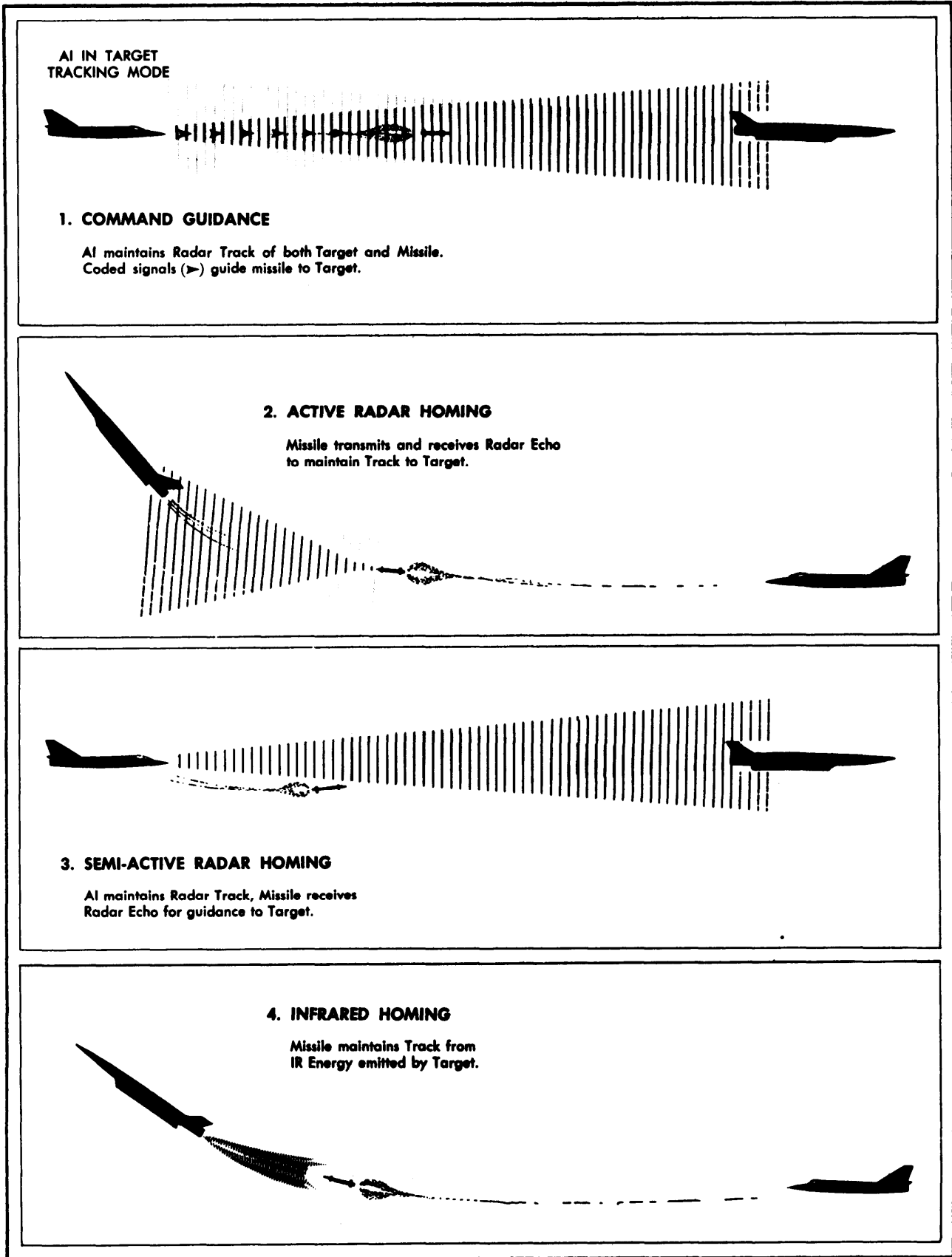

Figure 6-2. Missile Guidance Systems.

or lens serves to filter out unwanted frequencies such as those from IR radiation sources on the ground. The detection element need only be coupled to standard guidance system components to translate a detection ability into guidance commands.

A significant disadvantage of IR guidance is that the missile depends solely upon target IR radiations for guidance. Two main limitations for IR missiles are: heavy, moist cloud cover tends to attenuate or absorb a target's IR radiations; and, the missile may, under certain conditions, attempt to lock onto the sun.

Tracking by the AI's radar is not necessary once the IR missile has been launched; however, the AI may provide initial target acquisition to ensure the target is within firing range. Many modern AIs are equipped with IR sighting systems to provide target range independently of the radar. Therefore, countermeasures cannot be predicted solely upon the application of electronic jamming or chaff against the AI's radar. Tactics to counter the IR guidance system may consist of maneuvers to evade the missile or flares to decoy or confuse the missile's IR guidance system and degrade its tracking ability.

Command, active radar homing, semiactive radar homing, and IR are the four guidance techniques found in AAMs. As subminiature and microminiature electronic components become more widespread, it may be speculated that combinations of these guidance techniques may be incorporated into a single missile system. Such a combination would increase the missile's ability to complicate the task of developing effective countermeasures.

SURFACE-TO-AIR MISSILE (SAM) SYSTEMS

SAMs are predominately short- to medium-range weapons for use against attacking aircraft. They are found in the target area along predicted intruder approach routes and with accompanying armies and field units.

SAM systems, with respect to radar principles and ECM, may be considered as functioning in three phases. These phases are acquisition, target tracking, and guidance. Each of these phases is discussed, not for a particular system, but rather to illustrate the techniques which various systems have employed.

Acquisition

Long-range EWRs may first provide acquisition information. In advanced systems, this information is provided continuously and nearly instantaneously by automated data link systems. In tactical situations, the same information may originate from visual sightings with information relayed over radio-telephone. In either case, this advanced information provides the missile site with necessary preparation time to direct its own target acquisition radar to the approximate target location. Target acquisition radars used by individual systems have general beam characteristics similar to EWRs. Range capabilities vary widely, but a fair approximation would place detection at around 100 miles. More technically advanced acquisition radars are characterized by longer ranges, high resolution, better abilities against low altitude targets, and more sophisticated ECCM circuitry.

Countermeasures against the SAM acquisition radars are similar to those employed against the EWRs, including electronic jamming and chaff. Complete denial of acquisition information is a difficult task since target information might be provided from adjacent radars if the necessary communications links are available. However, until radar burn-through range is reached (refer to figure 4-14), ECM efforts effectively degrade the acquisition radar located with a specific missile site.

The missile site acquisition radar performs a function for the ground site similar to the search of the AI radar. It directs the tracking radar to the approximate position of the target. Without this assistance, target acquisition by the narrow-beam patterns characteristic of target tracking radars becomes much more difficult.

Target Tracking

The target tracking radar (TTR) has a dual role: track the target, and track the missile (figure 6-3). Most systems employ one or more of the following target tracking techniques: IR, visual, or radar.

IR tracking takes advantage of the EM emissions produced by an aircraft in flight. Aircraft engines, tailpipes, and other "hot spots" provide a well-defined point target for a sensor operating in the IR frequency range. The IR receiver in the missile seeker head is generally the only guidance needed when using this technique.

Visual target tracking is a technique that can be used to angularly follow the target. The missile can then be guided to the target using command guidance from the ground site. Another method of guidance could involve "illuminating" the visually tracked target with radar energy. A receiver in the missile then homes on the reflected radar energy. This is called semiactive homing.

Radar target tracking provides precise information on target range and angle which is provided to a computer that solves the intercept problem and prepares missile guidance commands. An additional radar may be used to track the missile in flight (figure 6-4), or the same TTR can be used (figure 6-5).

Command Guidance

Command guidance is an EM transmission to provide guidance to radar tracked SAMs. The target and missile position data are received by an intercept computer and the resultant guidance commands are transmitted to the missile. Various code structures, some of which have sophisticated anti-intrusion capabilities, are used to carry the computer commands via data link to the missile. Systems of the future may employ lasers as a means to convey guidance commands to the missile.

Track-Via-Missile

One of the most recent advances in missile guidance techniques is track-via-missile. This system combines elements from both command and active guidance systems. Track on the target and missile is established after missile launch by the TTR as in command guidance. As the missile closes in on the target, an active radar seeker head begins tracking the target. The information the missile seeker head obtains on the target is sent back to the TTR. The TTR now has two sources of information, its own and the input from the missile seeker. Using this information, the TTR can generate extremely accurate guidance commands. These guidance signals are sent back to the missile as in a command guidance system. Advantages to track-via-missile include a size and weight savings to the missile because it does not have to contain a computer for guidance information. Additionally, this smaller and lighter missile is more maneuverable. Furthermore, as the missile approaches the target, target tracking information from the TTR becomes more and more accurate. Finally, two radars are involved in guiding the missile which makes ECM against

the system difficult to accomplish (figure 6-5).

Initially, the SAM was developed to provide a capability against aircraft which had gained the ability to fly above the effective range of AAA. SAM altitude capabilities far surpass those of even the largest anti-aircraft guns, and it would appear that the warhead and altitude capabilities of the SAM systems would render AAA obsolete for air defense purposes, but such has not been the case. Experience has indicated that AAA is a deadly supplement and complement to SAM defenses.

ANTI-AIRCRAFT ARTILLERY (AAA)

Although not effective against high altitude aircraft, radar-controlled AAA does pose a significant threat to medium and low altitude aircraft. High rates of fire, mobility, and simple but effective fire control systems characterize modern AAA.

The following categories provide definition to the various sizes of modern anti-aircraft weapons:

Anti-aircraft (AA) machine guns (AAMG) (up to 20 mm).

Light AA artillery (LAAA) (21 mm to 75 mm).

Medium AA artillery (MAAA) (76 mm to 100 mm).

Heavy AA artillery (HAAA) (101 mm and over).

Radar fire control is not generally used with AAMGs, mainly because the effective range of the guns is fairly short (generally less than 5,000 feet) and fire is directed by the use of optical and mechanical sights. Control of LAAA may be optical or by fire control radars with effective ranges for LAAA to approximately 20,000 feet. MAAA and HAAA pieces may have optical sights as secondary controls, but radar is the primary means of control. Effective AAA ranges for the larger guns may extend up to 35,000 feet.

Acquisition of a target by AAA parallels that of the SAM. In most permanent installations used to defend strategic targets, AAA sites are tied electronically into the defense net. In a tactical situation, acquisition may depend upon visual sightings. Acquisition radars used for AAA target acquisition are similar to those used with SAM systems, with certain elements of the radar net being used by both systems. Generally, ECM comments applicable to the SAM acquisition radars apply also to the AAA acquisition radars.

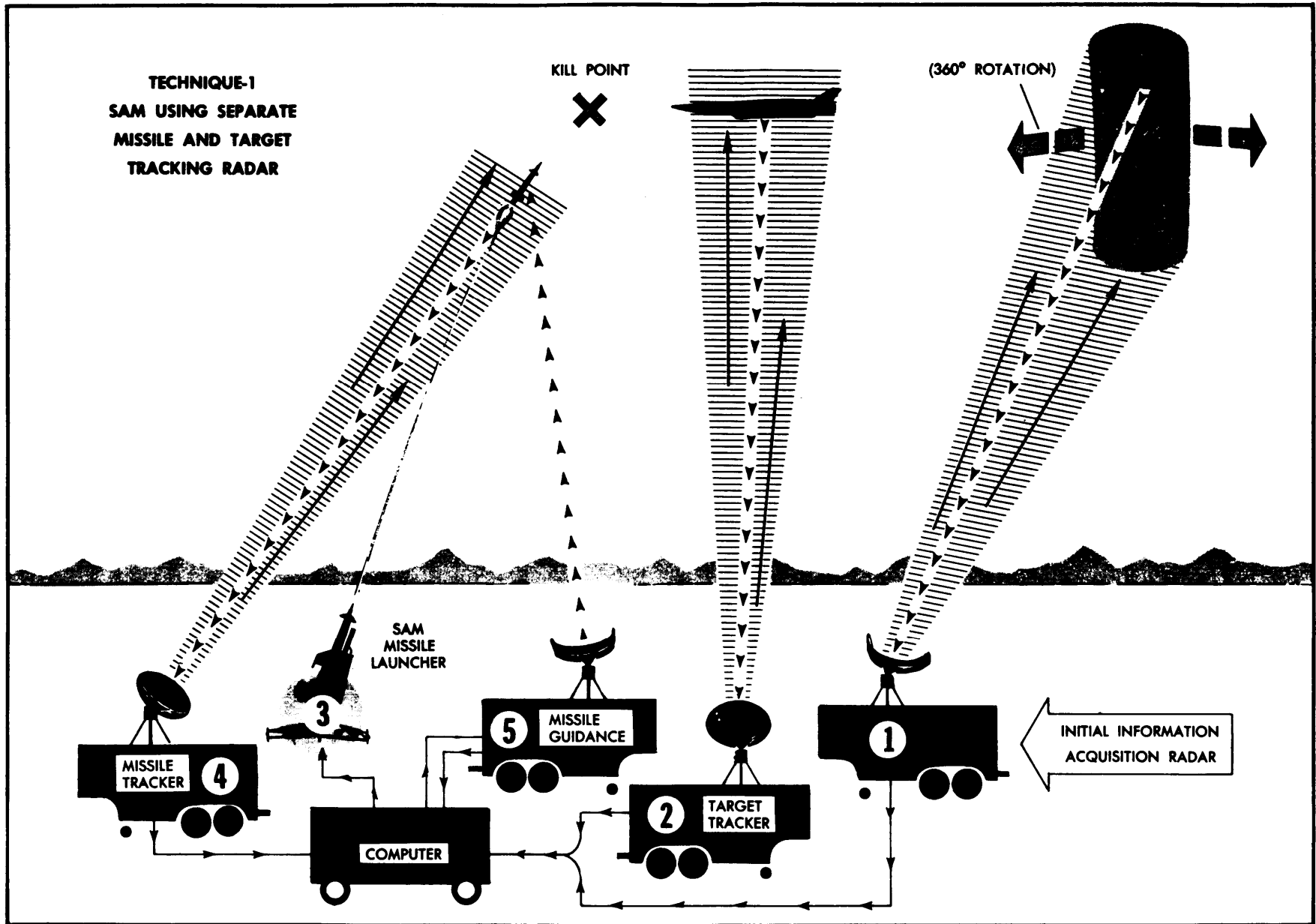

Figure 6-3. SAM Using Missile and Target Tracking.

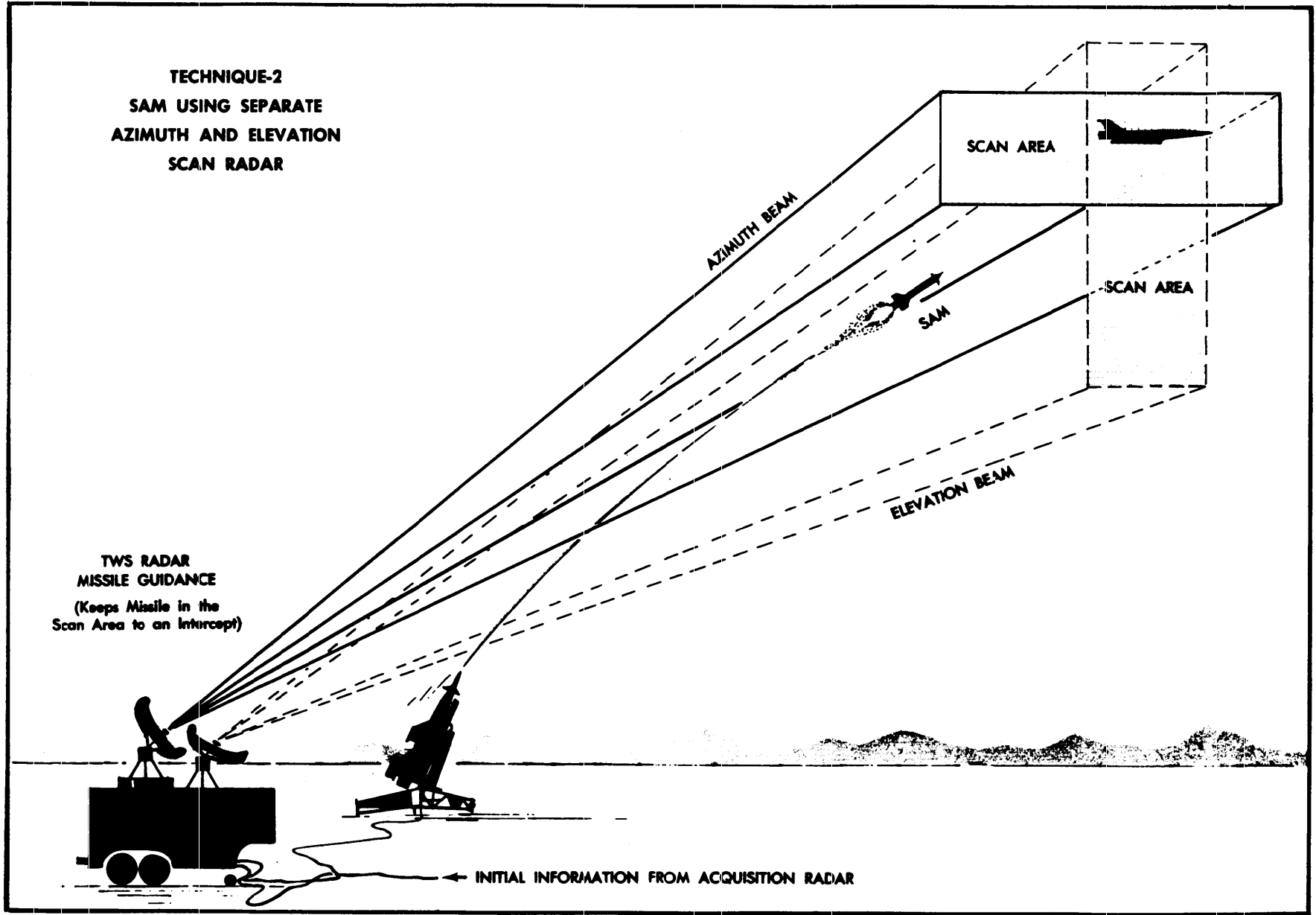

Figure 6-4. SAM Using Track-While-Scan.

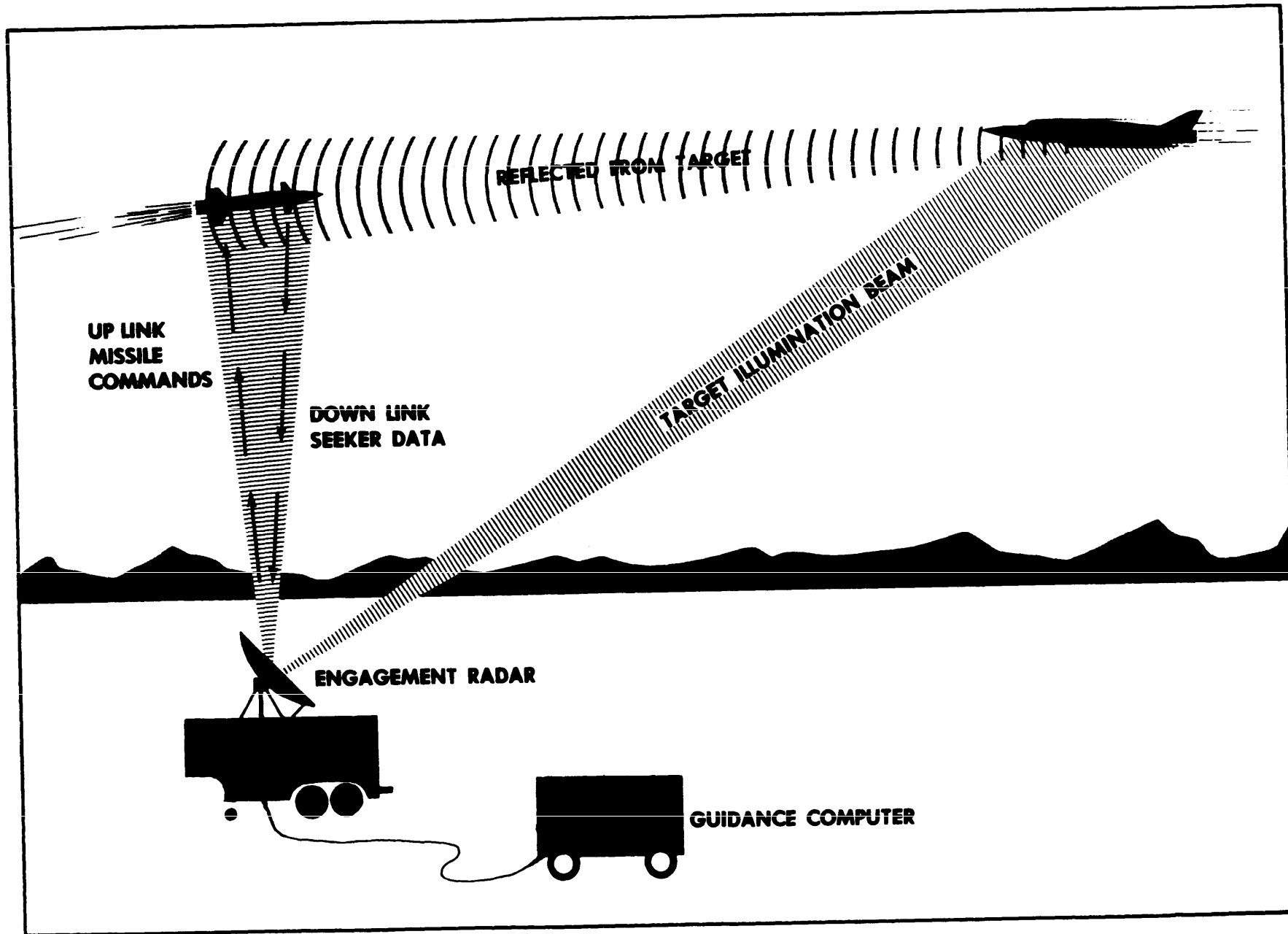

Figure 6-5. Track-Via-Missile Concept.

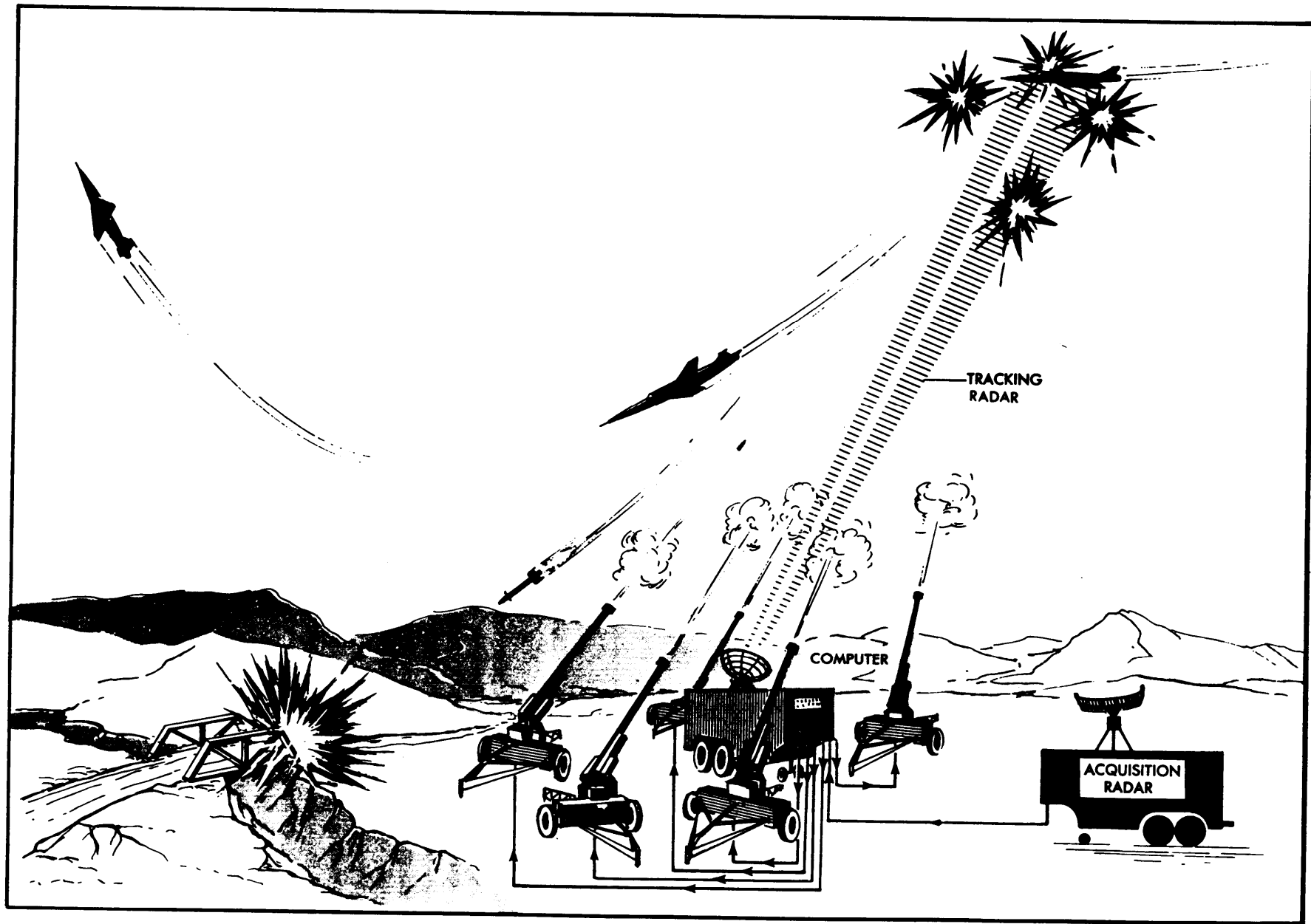

Figure 6-6. Typical AAA Battery Layout.

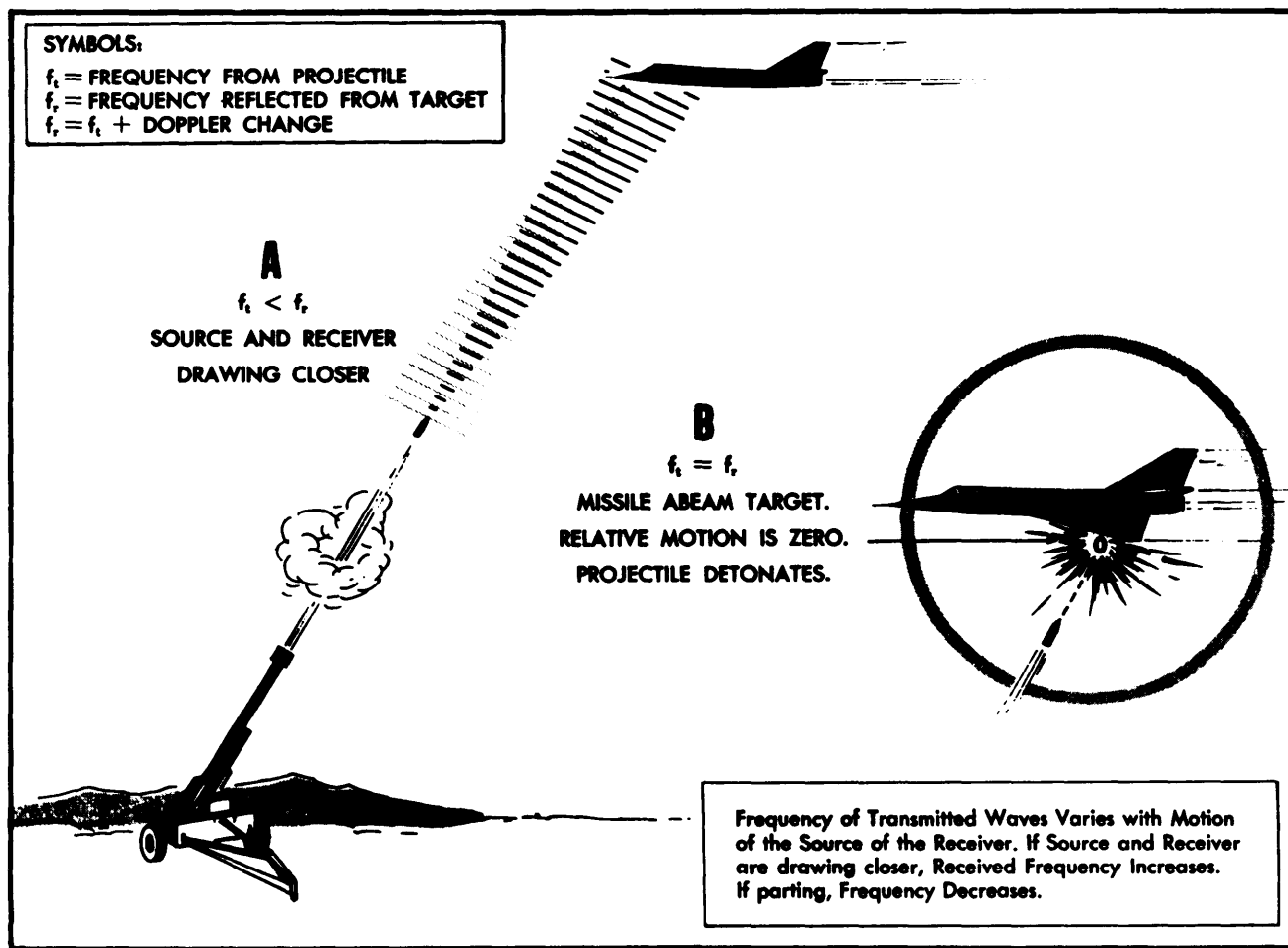

Figure 6-7. Radar Proximity Fused Projectile.

Target tracking for AAA may be accomplished through use of a precision conical scanning radar. The fire control radar provides precise range, azimuth, and elevation angle information. Tracking abilities may extend out to approximately 20 miles, but the effective ranges of the weapons are much shorter.

Countermeasures against the fire control radar generally consist of electronic radar jamming and (or) deception, and chaff may be used to provide general radar clutter, ECCM features of these radars are generally limited, but newly developed systems may be expected to include antichaff, antiground clutter, and home-on-jam features. The function of the antiground clutter circuits is to enable the radar to track low altitude aircraft which might otherwise be obscured by radar energy reflected from the adjacent terrain.

The functions performed by the radars are coordinated by a fire director. The fire director or computer receives the acquisition information

and directs the tracking radar to the target's azimuth. The target track data and other factors, such as wind, air density, and gun position, are entered into the computer by the director. The resulting commands automatically establish the firing order and appropriate lead angles for the individual guns of a battery. Figure 6-6 illustrates the layout of a typical AAA battery of site. The number of guns will vary, but the basic composition of a typical site is shown.

FUSES

Large artillery projectiles can carry an explosive warhead which is detonated by a fuse. Fuses are designed to activate the charge in a warhead at the proper time or altitude. There are three basic types of fuses: contact, variable time, and proximity.

Contact Fuse

A contact fuse is actuated when the warhead strikes the target. A time delay may be used with the contact fuse to allow warhead penetration of the target before detonation.

Variable Time Fuse

A variable time fuse is designed to explode a warhead at some predetermined flight time. A typical type of variable time fuse resembles a clock movement. The time delay interval must be set before the projectile is fired and cannot be changed in flight.

Proximity Fuse

Proximity fuses are actuated by some characteristic feature of the target or target area. Basic types of proximity fuses are photoelectric, acoustic, pressure, radar, and electrostatic. These fuses are present to function when the intensity of the target characteristic reaches a certain value. Proximity fuses are designed to detonate so that the warhead burst pattern occurs at an optimum location relative to the target.

The radar proximity fuse requires electronic control. This type of fused warhead contains a

miniature transmitting and receiving unit and, therefore, is vulnerable to ECM. Fuse activation relies upon the Doppler principle of frequency shift caused by the relative motion of source and receiver. As a target is approached, radar energy transmitted from the projectile is reflected back to the projectile and received as higher frequencies (figure 6-7). The difference between the transmitted frequency and the returning frequency is zero at the instant the target and projectile are abeam each other. The receiver portion of the fuse detects the zero difference and detonates the projectile.

SUMMARY

The terminal threat systems that aircrews must expect when penetrating modern defenses are formidable. The purpose of these systems is to destroy or negate the effectiveness of the striking force; however, from the first distant intercept by an AI to the detonations of AAA shells just prior to bomb release, a command thread ties these systems together—transmitted radar signals. It is these electronic signals that provide these weapons with much of their capabilities, and it is these electronic signals that the EW office can disrupt or distort through the use of ECM.

BY ORDER OF THE SECRETARY OF THE AIR FORCE

OFFICIAL

WILLIAMS O. NATIONS, Colonel, USAF
Director of Information Management
and Administration

LARRY D. WELCH, General, USAF
Chief of Staff

ABBREVIATIONS

A			
AA	- Antiaircraft	ECS	- Electronic Combat System
AAA	- Antiaircraft Artillery	EHF	- Extremely High Frequency
AAM	- Air-to-Air Missiles	ELINT	- Electronic Intelligence
AAMG	- Antiaircraft Machine Gun	EM	- Electromagnetic
ABCCC	- Airborne Command and Control Center	EO	- Electro-Optic
ABL	- American-British Laboratory	EOB	- Electronic Order of Battle
ACS/I	- Assistant Chief of Staff for Intelligence	EOCM	- Electro-Optical Countermeasures
ADC	- Air Defense Command	ESM	- Electronic Support Measures
AEW	- Airborne Early Warning	EW	- Electronic Warfare
AFEWC	- Air Force Electronic Warfare Center	EWAISF	- Electronic Warfare Avionics Integrated Support Facility
AF/IN	- Air Force Intelligence	EWIR	- Electronic Warfare Integrated Reprogramming
AFSC	- Air Force Systems Command	EWIRC	- Electronic Warfare Integrated Reprogramming Center
AFXO	- Air Force Plans and Operations	EWR	- Early Warning Radar
AGC	- Automatic Gain Control		
AI	- Airborne Interceptor	F	
AM	- Amplitude Modulation	FAA	- Federal Aviation Administration
ANMCC	- Alternate National Military Command Center	FAC	- Forward Air Controllers
ARC	- Area Reprogramming Capability	FEBA	- Forward Edge of the Battle Area
ARMS	- Antiradition Missiles	FLIR	- Forward-Looking Infrared
ASCAT	- Anti-SAM Combat Assistance Team	FLOT	- Forward Line of Troops
ASR	- Airport Surveillance Radar	FM	- Frequency Modulation
ATC	- Air Training Command	FSTC	- Foreign Science Technology Center
AVNL	- Automatic Video Noise Leveling	FTC	- Fast Time Constant
AWACS	- Airborne Warning and Control System	FTD	- Foreign Technology Division
B - C		G - H	
C ³	- Command, Control, and Communications	GCA	- Ground-Controlled Approach
C ³ CM	- Command, Control, and Communications Countermeasures	GCI	- Ground-Controlled Intercept
CLGP	- Cannon Launched Guided Projectile	HAAA	- Heavy Antiaircraft Artillery
COMINT	- Communications Intelligence	HBW	- Horizontal Beamwidth
CPS	- Cycles Per Second	HE	- High Explosive
D		HF	- Height-Finding/High Frequency
DC	- Direct Current	Hz	- Hertz
DCS	- Defense Communications System	I	
DF	- Direction-finding	IADS	- Integrated Air Defense System
DIA	- Defense Intelligence Agency	IAGC	- Instantaneous Automatic Gain Control
DOD	- Department of Defense	IED	- Imitative Electronic Deception
E		IF	- Intermediate Frequency
EC	- Electronic Combat	IR	- Infrared
ECM	- Electronic Countermeasures	IRCM	- Infrared Countermeasures
		IRWS	- Infrared Warning System
		J - K	
		JCS	- Joint Chiefs of Staff
		JEWC	- Joint Electronic Warfare Center

L

LAAA - Light Antiaircraft Artillery
 LASER - Light Amplification by Stimulated Emission of Radiation
 LD - Laser Designator
 LF - Low Frequency
 LORO - Lobe on Receive Only
 LRR - Long-Range Radar

M

MED - Manipulative Electronic Deception
 MEECN - Minimum Essential Emergency Communications Network
 MF - Medium Frequency
 MG - Machine Gun
 MGC - Manual Gain Control
 MIA - Missile Intelligence Agency
 MLRS - Multiple Launch Rocket System
 MMW - Millimeter Wave
 MRBM - Medium Range Ballistic Missiles
 MSL - Mean Sea Level
 MTI - Moving Target Indicator

N

NCA - National Command Authorities
 NCRC - National Defense Research Committee
 NEACP - National Emergency Airborne Command Post
 NISC - Naval Intelligence Support Center
 NM - Nautical Mile
 NMCC - National Military Command Center
 NSA - National Security Agency
 NSPS - Nonsynchronous Pulse Suppression

O

OCM - Optical Countermeasures
 OPSEC - Operations Security

P - Q

Pav - Average Power
 PD - Pulse Duration
 PGEU - Proving Ground Electronics Unit
 PM - Pulse Modulation
 PPI - Planned Position Indicator
 Ppk - Peak Power
 PPS - Pulses Per Second
 PRF - Pulse Recurrence Frequency
 PRI - Pulse Recurrence Interval
 PRT - Pulse Recurrence Time
 PW - Pulse Width
 PWD - Pulse Width Discrimination

R

RAM - Radar Absorbant Material
 RAP - Rocket-Assisted Projectile
 RCM - Radio Countermeasures
 RCS - Radar Cross-Section
 R&D - Research and Development
 RF - Radio Frequency
 RHI - Range Height Indicator
 RPV - Remotely Piloted Vehicles
 RRL - Radio Research Laboratory
 RT - Recovery Time
 RWR - Radar Warning Receiver

S

SAC - Strategic Air Command
 SAM - Surface-to-Air Missiles
 SEA - Southeast Asia
 SEAD - Suppression of Enemy Air Defenses
 SED - Simulative Electronic Deception
 SHF - Super-High Frequency
 SIGINT - Signal Intelligence
 SIOP - Single Integrated Operations Plan
 S/J - Signal-to-Jamming
 SLB - Side Lobe Blanking
 SLC - Side Lobe Cancellation
 S/N - Signal-to-Noise
 SON - Statement of Operational Need
 S/T - Scientific and Technological

T

TAWC - Tactical Air Warfare Center
 TFR - Terrain-Following Radar
 TTR - Target-Tracking Radar
 TTS - Track-While-Scan
 TWT - Traveling Wave Tube

U

UHF - Ultra-High Frequency
 US - United States
 USAFE - US Air Force in Europe
 UV - Ultraviolet

V - W

VBW - Vertical Beamwidth
 VHF - Very High Frequency
 VLF - Very Low Frequency
 WR-ALC - Warner Robbins Air Logistic Center
 WWMCCS - Worldwide Military Command and Control System